

# CDL

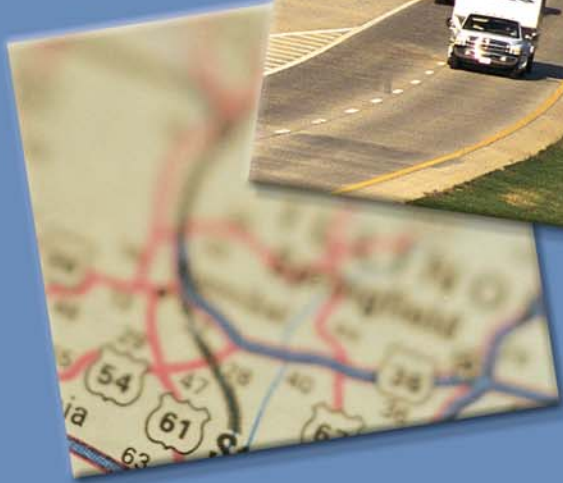

## **Commercial Driver's License STUDY GUIDE**

**Jesse White  
Illinois Secretary of State**

# TABLE OF CONTENTS

	Page
<b>Section 1: Illinois CDL</b>	
1.1 Commercial Motor Vehicle Safety Act, Nationwide CDL Program.....	3
1.2 Drivers Who Must Obtain a CDL .....	3
1.3 Drivers Exempt from Obtaining a CDL .....	3-4
1.4 Special Requirements for Certain Vehicles .....	4
1.5 Driver's License Classifications .....	4
1.6 Special Endorsements for Certain Vehicles.....	4
1.7 Commercial Driver's License Exams .....	5
1.8 MSCIA Rule .....	5
1.9 Documentation Required to Obtain a CDL.....	5-6
1.10 CDL Fees .....	6
1.11 Secretary of State CDL Facilities .....	7
1.12 CDL Reporting Requirements .....	8
1.13 CDL Alcohol Provisions .....	8
1.14 Other Offenses Leading to Disqualification .....	8-9
1.15 Size Limitations.....	9-10
1.16 Special Lighting Equipment.....	10-11
1.17 Vehicle Registration .....	11
1.18 Mechanical Safety Tests .....	12
1.19 Radar Detectors .....	12
<b>Section 2: Driving Safely</b>	
2.1 Vehicle Inspections .....	13-23
2.2 Basic Control of Your Vehicle .....	23-24
2.3 Shifting Gears .....	24-25
2.4 Seeing .....	25-26
2.5 Communicating .....	26-28
2.6 Controlling Speed .....	29-31
2.7 Managing Space .....	31-34
2.8 Driving at Night .....	34-35
2.9 Driving in Fog.....	36
2.10 Driving in Winter .....	36-37
2.11 Driving in Very Hot Weather .....	37-38
2.12 Railroad Crossings.....	38
2.13 Mountain Driving .....	38-39
2.14 Seeing Hazards .....	40-42
2.15 Emergencies .....	42-44
2.16 Skid Control and Recovery .....	44-45
2.17 Accident Procedures .....	45
2.18 Fires .....	46-47
2.19 Staying Alert and Fit to Drive .....	47-49
2.20 Hazardous Materials Rules for all Commercial Drivers .....	49-51
<b>Section 3: Transporting Cargo Safely</b>	
3.1 Inspecting Cargo .....	52
3.2 Weight and Balance .....	52-53
3.3 Securing Cargo .....	53-54
3.4 Cargo Needing Special Attention .....	54
<b>Section 4: Transporting Passengers</b>	
4.1 Pre-Trip Inspection.....	55
4.2 Loading and Trip Start .....	55-57
4.3 On the Road .....	57-58
4.4 After-Trip Vehicle Inspection .....	58
4.5 Prohibited Practices .....	58
4.6 Brake-Door Interlocks .....	58

The Office of the Secretary of State continues to do whatever is necessary to further ensure that all Illinois commercial driver's license holders are safe and responsible drivers. Toward that end, my office implemented a new policy, effective May 1, 2008, requiring all out-of-state CDL holders moving to Illinois to take and pass the written and road tests before being issued an Illinois CDL. Illinois is the first state in the nation to require these tests for licensed CDL holders moving from another state.



My office worked with the Federal Motor Carrier Safety Administration and other federal agencies on the policy as a result of findings of CDL testing irregularities in other states.

The collaborative effort uncovered a pattern in certain states where drivers who spoke little to no English and had questionable driving skills were able to obtain a CDL in those states.

About 2,400 drivers annually seek to exchange their out-of-state CDLs for an Illinois CDL. The policy change has received praise from law enforcement and trucking industry representatives and has set a standard for other states to follow.

In an effort to streamline test-taking procedures, CDL applicants may now schedule their pre-trip, skills and road exams online at [www.cyberdriveillinois.com](http://www.cyberdriveillinois.com). The new Illinois Fast Pass program takes just a few moments to schedule appointments and is accessible 24 hours a day, seven days a week.

This CDL Study Guide outlines the laws and requirements for commercial drivers. I encourage you to study this guide thoroughly before taking the required exams. My goal is to ensure that we license only safe and qualified drivers to operate commercial vehicles in the state of Illinois.

*Jesse White*

Jesse White  
Secretary of State



<b>Section 4-A: Charter Bus Endorsement</b> .....	59
<b>Section 4-B: School Bus Endorsement</b> .....	60-61
<b>Section 5: Air Brakes</b>	
5.1 Parts of Air Brake System .....	62-65
5.2 Dual Air Brake Systems .....	65
5.3 Inspecting Air Brake Systems .....	66-67
5.4 Using Air Brakes .....	67-69
<b>Section 6: Combination Vehicles</b>	
6.1 Driving Combination Vehicles Safely .....	70-72
6.2 Combination Vehicle Air Brakes .....	73-74
6.3 Coupling and Uncoupling .....	75-78
6.4 Inspecting a Combination Vehicle .....	78-79
<b>Section 7: Double/Triple Trailers</b>	
7.1 Pulling Double/Triple Trailers .....	80
7.2 Coupling and Uncoupling .....	80-82
7.3 Inspecting Doubles and Triples .....	82
7.4 Doubles/Triples Air Brake Check .....	83
<b>Section 8: Tank Vehicles</b>	
8.1 Inspecting Tank Vehicles .....	84
8.2 Driving Tank Vehicles .....	84-85
8.3 Safe Driving Rules .....	85
<b>Section 9: Hazardous Materials</b>	
Overview .....	86
9.1 Intent of Regulations .....	87
9.2 Hazardous Materials Transportation .....	87
9.3 Communication Rules .....	87-96
9.4 Loading and Unloading .....	96-99
9.5 Bulk Packaging Marking, Loading and Unloading .....	100
9.6 Hazardous Materials — Driving & Parking .....	101-102
9.7 Hazardous Materials — Emergencies .....	102-106
Table A—Radioactive Separation Table .....	107
Table B—Table of Hazard Class Definitions .....	107
Table C—Federal Motor Carrier Safety Regulations .....	108-112
Hazardous Materials Glossary .....	113-115
<b>Section 10: Pre-Trip Vehicle Inspection Test</b>	
10.1 All Vehicles .....	116-117
10.2 External Inspection (School Bus, Truck/Tractor) .....	118-120
10.3 School Bus Only .....	120-121
10.4 Trailer .....	121
10.5 Coach/Transit Bus .....	122
<b>Section 11: Basic Vehicle Control Skills Exam</b>	
11.1 Scoring .....	123
11.2 Exercises .....	124-127
<b>Section 12: On-Road Driving Exam</b>	
12.1 How You will be Tested .....	128-131

# Section 1: Illinois CDL

## 1.1 Commercial Motor Vehicle Safety Act — Nationwide CDL Program

The Commercial Motor Vehicle Safety Act of 1986 (CMVSA) was passed by Congress to address the problems caused by irresponsible and unqualified bus and truck drivers who are damaging the image of a safety-conscious profession. Unqualified drivers, often licensed following inadequate testing in many other states, have been found to be the cause of tragic accidents and other threats to highway safety. Many times, these drivers sought to escape responsibility for their actions by carrying driver's licenses issued by many states and spreading their traffic convictions among these licenses — thus avoiding suspensions or revocations.

The CMVSA was designed to stop these abuses by prohibiting drivers from holding more than one license. A nationwide information system prevents the issuance of multiple licenses, allows states to exchange information on traffic violations and makes it easier to remove problem drivers from the road. Those drivers who violate the law are subject to tougher penalties.

In addition, the law requires states to adopt uniform testing standards for commercial drivers prior to licensing. These testing standards are similar to those in effect in Illinois for years. Illinois was one of only 12 states to require testing in the type of vehicle for which an applicant is seeking a license.

Finally, sanctions for serious traffic violators will help ensure that commercial drivers remain accountable for their actions.

## 1.2 Drivers Who Must Obtain a CDL

A CDL must be obtained by the driver of any of the following vehicles:

- Any combination of vehicles with a gross combination weight rating (GCWR)\*\* of 26,001 or more pounds, providing the gross vehicle weight rating (GVWR)\* of the vehicle being towed is in excess of 10,000 pounds.
- Any single vehicle with a GVWR of 26,001 or more pounds, or any such vehicle towing another not in excess of 10,000 pounds.
- Any vehicle, regardless of size, designed to transport 16 or more persons, including the driver.
- Any vehicle required by federal regulations to be placarded while transporting hazardous materials.



\***GVWR** — Value specified by the manufacturer as the maximum loaded weight of a single vehicle or combination of vehicles, or the registered gross weight.

\*\***GCWR** — Value specified by the manufacturer as the GVWR of the power unit plus the GVWR of the towed unit or units, or the combined registered weight of the power unit plus the towed unit(s).



NOTE: For testing purposes only, the GCWR/GVWR means the value specified by the manufacturer as the maximum loaded weight of a single vehicle or combination of vehicles. For the pre-trip, skills and road test, a proper class vehicle is required.

## 1.3 Drivers Exempt from Obtaining a CDL

Under state and federal law, certain drivers are not subject to the requirements of the CDL program. The Federal Motor Carrier Safety Administration has determined that these exemptions will not diminish the safe operation of commercial vehicles on the highways.

The following vehicle operators are not required to obtain a CDL:

**Farm Equipment Operators** — This exemption covers legitimate farm-to-market operations by farmers, not commercial grain haulers. CDLs are not required to operate vehicles:

- Controlled and operated by a farmer, a member of the farmer's family or an employee;
- Used to transport farm products, equipment or supplies to or from a farm (including nurseries and aquacultures);
- Used within 150 air miles of the farm; and
- Not used in the operations of a common or contract carrier; and
- Used in nursery or agricultural operations.

NOTE: The farmer, his or her spouse and their children, parents on both sides, brothers and sisters on both sides and their spouses operating a truck-tractor semitrailer and meeting the above criteria also are exempted from the CDL Program. These drivers must be at least age 21, and the vehicle must have Farm plates. These drivers are still required to take the appropriate CDL written, skills and road tests to be licensed.

**Firefighting Equipment Operators** — Because most firefighting organizations have extensive initial training and re-training requirements for their equipment operators, Illinois waives CDL requirements for operators of firefighting equipment owned or operated by or for a government agency.

**Military Vehicle Operators** — Operators of military vehicles for military purposes are exempt from obtaining a CDL.

**Recreational Vehicle Operators** — Recreational vehicle operators, when using the vehicle primarily for personal use, do not need a CDL.

### 1.4 Special Requirements for Certain Vehicles

To operate the following vehicles, a driver must meet special requirements established by other governmental agencies:

- School buses (individuals should contact their local school districts).
- Religious organization buses.
- Child care vehicles.
- Vehicles used in for-profit ride sharing programs.
- Vehicles used for senior citizen transportation.

A driver should check with his/her employer or the local Driver Services facility to obtain the special requirements for operating these types of vehicles, or call the Safe Ride Section at 217-785-2543.

The Commercial Motor Vehicle Safety Act of 1986 establishes a uniform national classification system.

### 1.5 Driver’s License Classifications

- Class A — Combination vehicles - GCWR\* of 26,001 or more pounds providing the GVWR of the vehicle being towed is in excess of 10,000 pounds.
- Class B — Single vehicle with a GVWR\* of 26,001 or more pounds, or any such vehicle towing another not in excess of 10,000 pounds.
- Class C — Single vehicle with a GVWR\* of at least 16,001 pounds but less than 26,001 pounds.
- Class D — Single vehicle with a GVWR\* of less than 16,001 pounds.

\*GCWR — Gross Combination Weight Rating

\*GVWR — Gross Vehicle Weight Rating

### 1.6 Special Endorsements for Certain Vehicles

There are seven special CDL endorsements and one restriction that require testing, which are summarized below. In addition, drivers who do not pass the air brake portion of the exams are restricted to driving vehicles without air brakes.

To Qualify to Drive: Type of Vehicle (Endorsement/Restriction)	You must take this exam(s):	
	Knowledge Exam	Skills and Driving Exam
Charter Bus Endorsement (C)	X	X
Combination Tank and Hazardous Materials (X)	X	
Double/Triple Trailers (T)	X	
Passenger Vehicles (P)	X	X
School Bus Endorsement (S)	X	X
Tank Vehicles (N)	X	
Vehicles Carrying Hazardous Materials (H)	X	
Vehicle Without Air Brakes (L-RESTRICTION)	X	X

## 1.7 Commercial Driver's License Exams

In addition to the vision screening required for all drivers, all CDL applicants are required to pass a written exam, and most are required to pass a skills and driving exam.

**Computerized Written Knowledge Exam** — The computerized written knowledge exam consists of standardized multiple-choice questions, which all CDL applicants must answer. In addition, specialized exams are added if you wish to operate any of the following vehicles: vehicles with air brakes (also requires a skills and road test), combination vehicles, double or triple trailers, vehicles carrying hazardous materials, passenger-carrying vehicles, school buses or tanker vehicles.

**Third-time Fail Rule** — CDL applicants who fail any CDL exam(s) three (3) times are required to wait 30 days from the date of the third failed exam. Three additional failures (6 total failures) of the same exam(s) will result in a 90-day waiting period. Three additional failures (9 total failures) of the same exam(s) after the 90-day waiting period will result in a one-year waiting period from the date of the last failed exam. The waiting periods apply only to the exam(s) failed three times.

**Skills and Driving Exam** — After passing the written exam, some drivers are required to pass a skills and driving exam. The exam is divided into three parts:

- 1) **The pre-trip inspection** is conducted to determine whether the applicant knows how to inspect the vehicle to see if it is safe to drive. Drivers are asked to conduct a pre-trip inspection. The driver must explain to the examiner what is being inspected and why. Section 2.1 and Section 10 of this study guide explain the pre-trip inspection.
- 2) **The basic control skills exam** evaluates a driver's ability to use basic skills to control the vehicle. Applicants complete exercises on a course marked by lines, traffic cones or similar boundaries. The exercises test the driver's ability to move the vehicle forward, backward and through turning movements. Drivers are scored on how well they stay within the boundaries.
- 3) **The driving exam** tests the driver's ability to drive safely in a variety of on-road situations. The road test route may include left and right turns, intersections, railway crossings, curves, upgrades, downgrades, rural or semi-rural routes, multi-lane city streets and/or expressway driving.

**Special Requirements** —

- **Effective May 1, 2008, out-of-state applicants must take all CDL written and road exams to secure an Illinois CDL.**
- A CDL instruction permit expires one year from the issuance date. All CDL written exams must be retaken to renew an instruction permit. Written exams are valid for one year.
- A CDL holder requiring a Hazardous Materials Endorsement (HME) must complete a Transportation Security Administration (TSA) form and submit to a fingerprint background check.

**Illinois Fast Pass** — You may now schedule CDL exams online at [www.cyberdriveillinois.com](http://www.cyberdriveillinois.com).

## 1.8 MCSIA Rule

All CDL holders are required by federal law to provide a one-time, 10-year driving history check on renewal or surrender an out-of-state license to obtain an Illinois CDL. CDL holders applying for a corrected or duplicate license also are required to submit to a one-time, 10-year driving history check.

Any person found cheating on any portion of a written exam will fail that portion of the exam. In addition, the person is prohibited from retaking the exam for a period of 30 days. "Cheating" is defined as receiving or using unauthorized assistance in the taking of any portion of an exam, including, but not limited to, the use of notes, books or written information.

In Illinois, any person convicted of offering a bribe to anyone authorized by law to provide driving instructions or administer driver's license exams may have his/her driving privileges suspended or withheld for 120 days. The offense is a Class 2 felony, which carries a three to seven year prison sentence and fines of up to \$25,000.

## 1.9 Documentation Required to Obtain a CDL

As is required for any driver's license, CDL applicants are required to show documentation verifying their identity, age, Illinois residency, signature and Social Security number.

Most operators of commercial vehicles with a gross motor vehicle weight of 10,001 pounds or more are required to carry a Medical Examiner's Certificate with them at all times while operating a second division vehicle. In addition, these drivers are required to maintain a file that contains a written exam verification, driving exam verification and other records.

The Secretary of State's office is not responsible for regulating or enforcing these regulations and does not have the forms necessary for compliance with these regulations. Enforcement is the responsibility of the Illinois State Police. All required forms and informational material are available from the following organizations:

**J.J. Keller & Associates, Inc.**  
3003 W. Breezwood  
Neenah, WI 54956  
800-327-6868

**Mid-West Truckers Association**  
2727 N. Dirksen Pkwy.  
Springfield, IL 62702  
217-525-0310

**Illinois Transportation Association**  
7000 S. Adams, Ste. 130  
Willowbrook, IL 60527  
630-654-0884

In addition, commercial vehicle drivers must:

- Be at least age 21 to drive a commercial motor vehicle across state lines, carry hazardous materials or transport any passengers.
- Certify that they do not have more than one driver's license, and that their driving privileges are not suspended, revoked, cancelled or disqualified.
- Certify that they meet the medical requirements of the Federal Motor Carrier Safety Regulations or that they are not subject to the regulations.

#### **Do I Need a DOT Medical Card?**

Yes, if you:

1. Operate a commercial vehicle with a gross vehicle weight rating (GVWR) or a gross combination weight rating (GCWR) of 10,001 pounds or more in the furtherance of a commercial enterprise (private or for hire); or
2. Operate a passenger carrying vehicle designed to transport 16 or more passengers including the driver; or
3. Operate any vehicle transporting hazardous materials of a quantity that would require placarding.

For more information regarding the Motor Carrier Safety Regulation, see Table C on pages 108-112, or contact:

**IDOT**  
**Commercial Vehicle Safety Section**  
**Motor Carrier Safety Unit**  
3215 Executive Park Dr.  
Springfield, IL 62703  
217-785-1181

### **1.10 CDL Fees**

**The fee for a CDL is \$60. The fee for a CDL permit is \$50.** This includes \$10 for the basic driver's license, \$24 for the CDL, \$6 to cover the cost of the national commercial driver's license information system, and \$20 for the Motor Carrier Safety Inspection Fund. A \$5 fee is assessed for CDL holders who wish to change classifications or endorsements.



## 1.11 Secretary of State CDL Facilities

**Written and driving exams are available at the following facilities:**

Bradley 1111 Blatt St. Bradley, IL 60915 815-933-1713	Elk Grove Village 650 Roppolo Dr. Elk Grove Village, IL 60007 847-981-7447	Peoria 3311 N. Sterling Ave., #12 Peoria, IL 61604 309-686-6040	Salem 1375 W. Whittacker Salem, IL 62881 618-548-2381
Danville/Tilton #5 Southgate Tilton, IL 61833 217-442-1564	Marion 1905 Rendleman St. Marion, IL 62959 618-993-2587	Princeton 225 Backbone Rd. East Princeton, IL 61356 815-875-2617	South Holland 41 W. 162nd St. South Holland, IL 60473 708-210-3540
DeKalb 1360 Oakwood St. DeKalb, IL 60115 815-756-7781	Moline/Silvis 2001 5th St., Ste. #10 Silvis, IL 61282 309-796-0934	Quincy 2512 Locust St. Quincy, IL 62301 217-222-4550	Springfield 2701 S. Dirksen Pkwy. Springfield, IL 62723 217-782-6030
East St. Louis 8750 Church Ln. East St. Louis, IL 62203 618-397-9488	Morris 2413 Sycamore Dr. Morris, IL 60450 815-942-5154	Rantoul 421 S. Murray Rd. Rantoul, IL 61866 217-892-8773	West Chicago 1280 Powis Rd. West Chicago, IL 60185 630-293-1191
Effingham 444 S. Willow Effingham, IL 62401 217-347-7728	Olney 1302 S. West St. Olney, IL 62450 618-395-1702	Rockford 3816 Auburn St. Rockford, IL 61101 815-987-7383	

\* To schedule a driving exam at the Elk Grove, West Chicago or South Holland facilities, please call 630-293-1191, Tues.-Fri., 8 a.m.-5 p.m.

\* To schedule a driving exam at any other of the above facilities, please call 217-785-3013, Mon.-Fri., 8 a.m.-4:30 p.m.

**Written exams only available at the following facilities:**

Bellefonte 400 W. Main Bellefonte, IL 62220 618-236-8450	Edwardsville 1502A Troy Rd. Edwardsville, IL 62025 618-656-8956	Libertyville 342 Peterson Rd. Liberty, IL 60048 312-793-1010	Pontiac 507 Crain St. Pontiac, IL 61764 815-844-5766
Bethalto 20 Terminal Dr., Ste #103 East Alton, IL 62024 618-258-0600	Fairfield 307 N. Market Ave. Fairfield, IL 62837 618-842-9548	Macomb 466 Deer Rd. Macomb, IL 61455 309-833-5661	Roanoke 106 W. Broad St. Roanoke, IL 61561 309-923-6381
Bloomington 1510 W. Market Bloomington, IL 61701 309-827-3531	Freeport 1793 S. West Ave. Freeport, IL 61032 815-235-4164	Mattoon 2020 Charleston Mattoon, IL 61938 217-234-4040	Robinson 1411 E. Main Robinson, IL 62454 618-544-8118
Carbondale 2516 W. Murphysboro Rd. Carbondale, IL 62901 618-457-0488	Galesburg 1066 E. Losey Galesburg, IL 61401 309-342-1154	Metropolis 1112 W. 10th Metropolis, IL 62960 318-524-7451	Rockford Central 3720 E. State Rockford, IL 61101 815-394-0179
Carmi 1128 W. Oak Carmi, IL 62821 618-383-8349	Hillsboro 2010 School Hillsboro, IL 62049 217-532-5823	Nashville 480 N. Kaskaskia St. Nashville, IL 62263 618-327-4184	Sparta 202 W. Jackson Sparta, IL 62286 618-443-3834
Champaign 2401 W. Bradley Champaign, IL 61821 217-278-3344	Jacksonville Lincoln Square Shopping Center Jacksonville, IL 62650 217-243-4327	Pekin 200 S. 2nd Pekin State Plaza Pekin, IL 61554 309-346-6186	Springfield 316 N. Klein St. Springfield, IL 62702 217-782-4850
Decatur 3149 N. Woodford Decatur, IL 62526 217-875-1650	Jerseyville 710 County Rd. Jerseyville, IL 62052 618-498-5731	Plano 712 E. South St. Plano, IL 60545 312-793-1010	Sterling 1224 W. 4th St. Sterling, IL 61081 815-626-2825

**Exams also may be scheduled online through Illinois Fast Pass at [www.cyberdriveillinois.com](http://www.cyberdriveillinois.com).**

## 1.12 CDL Reporting Requirements

Reporting requirements under the CDL program have been in effect since 1988. Commercial drivers must notify the Secretary of State of the following:

- Any out-of-state traffic violation within 30 days of conviction.
- Any out-of-state suspension, revocation or cancellation of driving privileges, as well as disqualification or out-of-service actions, within 30 days of the effective date.
- Change of name or address within 10 days. The driver has 30 days to obtain a corrected CDL.

Commercial drivers also must notify their employer of the following:

- Any traffic violation within 30 days of the date of conviction.
- Any suspension, revocation or cancellation of their driving privileges, as well as any disqualification or out-of-service action, within one day of notification of action.
- Complete employment and driving record for the previous 10 years.

## 1.13 CDL Alcohol Provisions

Illinois law requires drivers operating a commercial motor vehicle (CMV) or a non-commercial motor vehicle (non-CMV) on highways to automatically give their consent to submit to certain tests to determine blood-alcohol concentration (BAC). The illegal BAC limit for a CDL holder operating a CMV is .04 percent and .08 percent for a non-CMV with the following provisions:

- Any driver operating a CMV or non-CMV who refuses to submit to a blood-alcohol test or submits to a test with results in excess of the illegal limit is disqualified for at least 12 months.
- Any driver convicted of DUI (regardless of BAC) is disqualified for at least 12 months.
- If either violation above takes place while transporting placarded hazardous materials, the driver is disqualified for at least three years.
- A driver who commits two of the above violations, arising from two or more incidents, is disqualified for life.
- A CDL holder operating a CMV found to have any alcohol in his or her system is placed out of service for at least 24 hours.
- Anyone convicted of driving a commercial motor vehicle with any amount of drug, substance or compound resulting from unlawful use or consumption of cannabis listed in the Cannabis Control Act or controlled substance listed in the Controlled Substance Act is disqualified for at least 12 months.

## 1.14 Other Offenses Leading to Disqualification

The following offenses also will lead to disqualification:

- Knowingly and willfully leaving the scene of an accident while operating a CMV or non-CMV results in disqualification for at least 12 months.
- Committing a felony while operating a CMV or non-CMV results in disqualification for at least 12 months.
- A conviction for either offense above while carrying placarded hazardous materials results in disqualification for at least three years.
- A conviction for violation of an out-of-service order results in disqualification for at least six months.
- The use of a CMV or non-CMV in the commission of any felony involving manufacturing, distributing or dispensing a controlled substance, or possession with intent to manufacture, distribute or disperse a controlled substance, results in a lifetime disqualification.
- If convicted of operating a commercial motor vehicle in violation of regulations pertaining to railroad-highway grade crossings: first conviction — 60-day disqualification; second conviction within a three-year period —120-day disqualification; third and subsequent conviction within a three-year period — one-year disqualification.

**Excessive Speeding** — Excessive speeding involving any single offense for any speed of 15 mph or more above the posted speed limit.

- Failure to reduce speed to avoid an accident.
- Driving too fast for conditions.
- Exceeding the speed limit in a school zone.

**Reckless Driving** — Operating a CMV or non-CMV in a manner that exhibits a willful, wanton or reckless disregard of the safety of persons or property.

- Passing a vehicle stopped for a pedestrian in a crosswalk.
- Driving on a sidewalk.
- Passing a school bus receiving or discharging passengers or displaying a warning not to pass.

**No Valid CDL** — Operating a CMV without a valid CDL.

- Operating a CMV with an improper classification or restriction.
- Violation of an instruction permit.

**Following Too Closely** — Following the vehicle ahead too closely.

- Failure of a truck to leave sufficient distance for being overtaken by another vehicle.

**Improper Lane Usage** — Improper or erratic traffic lane changes.

- Improper lane changing, lane usage and/or center lane usage.
- Improper passing.
- Passing on a hill or curve or when prohibited.
- Passing on wrong side of the road.
- Improper passing on shoulder, left or right.
- Driving wrong way on a one-way street or highway.
- Driving on the left side of the roadway.
- Passing in a school zone.

**Conviction Involving a Fatal Accident** — A violation of any state law or local ordinance relating to motor vehicle traffic control (other than parking violations) arising in connection with a fatal traffic accident.

**Multiple Licenses** — A violation relating to a CMV driver having multiple driver's licenses.

**Traffic Violations** — Two serious traffic violations within a three-year period results in a two-month disqualification. Three serious traffic violations in the same period results in a four-month disqualification.

## 1.15 Size Limitations

Drivers must obey all posted signs regarding maximum truck width, length, height and weight limits. They must be aware that some highways prohibit truck travel entirely. Others allow truck travel on a limited basis. For example, only very small trucks may cross certain township bridges as well as the highways leading to and from these bridges. Higher limits are allowed on state highways designated by the Illinois Department of Transportation (IDOT) and on local streets and highways designated by local government officials. These heavier and larger vehicles and combinations are allowed to travel on non-designated streets or highways in the state highway system for up to five miles to gain access to a designated roadway. These vehicles are prohibited on all streets and highways under local jurisdiction unless designated by local officials. Maps showing state highways on which these vehicles may operate from are available by calling IDOT, 217-782-6271.

**Width** — The maximum width for most vehicles is 8 feet, except on designated Class I and Class II state highways and designated local roads where a width of 8 feet, 6 inches, is allowed. Exemptions to maximum widths are:

- Loads of farm products or implements of husbandry being transported during the period from one-half hour after sunrise to one-half hour before sunset in times of good visibility.
- Buses operating within the limits of cities and villages located in counties with populations of 500,000 or more. Maximum widths may be up to 9 feet. However, no vehicle wider than 8 feet, 8 inches, may be operated on the interstate highways in those counties.

**Length** — No vehicle with or without a load, other than a semitrailer, shall exceed a length of 42 feet. Semitrailers may have an overall length of 53 feet, including the load being carried. However, for semitrailers more than 48 feet in length, the maximum allowable distance from the king pin to the rear axle is 40 feet. The maximum length of either the semitrailer or trailer in a truck tractor-semitrailer-trailer (double-bottom) combination is 28 feet, 6 inches.

- On Class I designated state and local highways there is no overall length limit.
- On Class II designated state and local highways there is no overall length limit; however, the maximum allowable wheel-base is 55 feet for truck tractor-semitrailer combinations, and 65 feet for truck tractor-semitrailer-trailer (double-bottom) combinations.
- On Class III highways and the remainder of the state highway system, the maximum allowable wheelbase is 55

feet for the truck tractor-semitrailer combinations. All other types of vehicle combinations are limited to an overall length of 60 feet, including load.

- On non-designated local streets and highways, the maximum overall length is 55 feet, including loads for truck tractor-semitrailer combinations, and 60 feet for all other types of vehicle combinations.

A combination of vehicles specially designed to transport motor vehicles may have an overall length of 65 feet plus a front overhang of 3 feet and a rear overhang of 4 feet on Class I and II highways. On all other highways and streets, the maximum overall length is 60 feet including load.

Exceptions to these limitations are vehicles hauling pipes, poles, machinery or other structural objects that cannot be quickly taken apart. However, the length of these objects may not exceed 80 feet, except for public utility emergency repairs or for those holding special permits. These vehicles are not allowed to operate when it is dark or on Saturdays, Sundays and legal holidays.

**Height** — The maximum height for all vehicles on all highways is 13 feet, 6 inches, including load from the underside of the tire to the top of the vehicle.

**Weight** — The maximum weight limits on designated state and local streets and highways are:

- 20,000 pounds on a single axle
- 34,000 pounds on a tandem, and
- up to 80,000 pounds on a 5-axle combination, depending upon axle spacings.

On non-designated streets and highways the limits are:

- 18,000 pounds on a single axle, 32,000 pounds on a tandem, and
- up to 73,280 pounds on a 5-axle combination.

However, any single axle of a 2-axle motor vehicle weighing 36,000 pounds or less and not a part of a combination of vehicles may carry an axle load of up to 20,000 pounds. Exceptions for certain vehicles are allowed by the statutes and by local city ordinances.

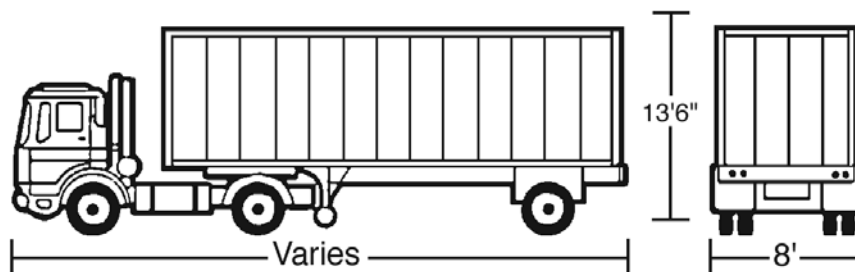

## 1.16 Special Lighting Equipment

Second division or combination vehicles longer than 25 feet or wider than 80 inches (excluding mirrors, bumpers and other safety devices) must have special lighting equipment. The following lighting equipment is required on vehicles operated outside the limits of cities, towns or villages between sunset and sunrise:

- Two yellow or amber lights on the front of the vehicle. One light must be on each upper-front corner and visible for 500 feet.
- Three red lights on the rear of the vehicle in a horizontal line and visible for 500 feet.
- Two yellow or amber reflectors on the front of the vehicle. One reflector must be on each lower corner.
- Two red reflectors on the rear of the vehicle. One reflector must be not more than 12 inches from each lower corner.

Second division or combination vehicles longer than 20 feet and weighing more than 3,000 gross pounds must have special reflectors when operated outside the limits of cities, villages or towns between sunset and sunrise. The required reflectors, which must be approved by IDOT include:

- Two amber reflectors on each side of the vehicle, not more than 5 feet above the road and placed at approximately 1/3 the length of the side of the vehicle.
- One amber reflector on each side of the vehicle not more than 12 inches from the front and not more than 5 feet above the road.
- One red reflector on each side of the vehicle not more than 12 inches from the rear and not more than 5 feet above the road.

- Special lighting equipment required on trailers and semitrailers with a gross weight of 3,000 pounds or less include:
- Two red reflectors on the rear of the vehicle. Reflectors must not be more than 12 inches from each lower corner and visible for 300 feet in headlight beams.
  - Electric turn signals. Vehicles must have right and left signals on the front and rear. They must be visible from 300 feet.

## 1.17 Vehicle Registration

**Registration ID Cards** — Registration identification cards for second division vehicles, except pole trailers or semitrailers, must be in the vehicle, carried by the driver or carried by the person in control of the vehicle at all times. Vehicles weighing over 12,000 pounds that are registered in another state must carry an Illinois Fleet Reciprocity ID Permit, Apportionment ID Card or Prorate ID Card (for Prorate Decals) in place of the registration ID card.

**Motor Fuel Tax ID Card** — When required by the Motor Fuel Tax Law, a valid Motor Fuel Tax Identification Card or an authorized reproduction must be carried in the cab of the vehicle or carried by the driver. The driver must display or surrender the card upon request of a police officer or other agent of the Department of Revenue.

Second division registration fees are based on the type of operation and the gross weight of the vehicle and load. The fee schedule is printed on the application, which may be obtained from the Secretary of State's office.

**License Plates** — All vehicles except motorcycles, motorized pedalcycles, trailers, semitrailers, truck tractors and vehicles registered under the International Registration Plan (IRP) must display two license plates (front and rear) on the vehicle. Trailers must display one on the rear, and truck tractors must display one on the front. Buses registered under the IRP must display one apportioned plate on the rear of the bus.

The IRP is a reciprocity agreement between the states and the Canadian provinces, providing for the payment of license fees to a specific jurisdiction based on the number of fleet-miles driven in that jurisdiction. A license plate and an Illinois Apportionment Identification Card listing the jurisdictions for which the fees have been paid are issued for each vehicle by the base state of the applicant. The gross weight at which the vehicle has been registered also is listed. Vehicles with a maximum gross weight over 26,000 pounds are required to display IRP plates. Lighter vehicles that conduct interstate commerce may choose to display these plates, while those that conduct intrastate commerce must have IRP plates.

**Apportionment Plates** — Specific kinds of license plates are issued for second division vehicles. License plates for second division vehicles are issued for the fiscal year beginning July 1 and ending June 30. Apportioned plates and prorate plates/decals are issued for the calendar year beginning January 1 and ending December 31. Semitrailer plates are five-year calendar plates.

Intrastate carriers may not operate any motor vehicle on Illinois highways unless there is a sign painted on or affixed to both sides of the vehicle. The trade name, permit number and registration number of the carrier must be shown. The letters on the sign must be a minimum of 2-inches-high with a 1/2-inch brush stroke. Interstate carrier vehicles must show the registration or authority number of the carrier on both sides of the unit.

All tow trucks except those owned by governmental agencies must display a sign on each side. The sign must have letters not less than 2-inches-high, which contrast with the background. The sign must state the name, address and telephone number of the owner or operator.



**Movement Documents** — A movement document ensures that *only vehicles in Illinois* do intrastate business within the boundaries of Illinois. All trucks, truck tractors and buses registered in another state must carry one or more movement documents that show:

- The vehicle's point of origin and destination and its cargo or passengers.
- Whether the trip is for-hire or not-for-hire.
- Whether the trip is interstate or intrastate as defined by the Illinois Vehicle Code.

## **1.18 Mechanical Safety Tests**

Most second division and medical transport vehicles must have a Certificate of Safety before being driven on Illinois highways. Safety inspections are required every six months.

The following vehicles are subject to safety inspection semi-annually:

- Trucks registered with a gross weight of more than 8,000 pounds; trucks that pull a trailer with a gross weight of more than 8,000 pounds; trailers with a gross weight of more than 5,000 pounds; motor buses; religious organization buses;
- Buses registered as charitable vehicles; senior citizen transport vehicles; school buses; medical transport vehicles; tow trucks; limousines.

Garages or service stations licensed by IDOT may make safety inspections. Second division vehicles not required to pass safety inspections include:

- Vehicles with a gross weight of 8,000 pounds or less.
- Farm tractors, machinery and other implements.
- Vehicles owned or operated by the city of Chicago, which display proof of ownership.
- Vehicles owned or operated by the federal government, which display proof of ownership.
- Vehicles registered as recreational vehicles, which display proper plates.
- Properly licensed antique vehicles.
- Specialized vehicles as defined by statute.
- Vehicles properly registered in another state.

When a vehicle passes inspection, the driver is issued a Certificate of Safety windshield decal and an inspection report. The decal must be displayed on any vehicle using public roadways.

## **1.19 Radar Detectors**

Illinois law prohibits CMVs from being equipped with any instrument designed to detect the presence of, or interfere with, microwaves at frequencies used by police radar for the purpose of monitoring vehicle speed. The term “equipped” means and includes possession or use within a CMV.

A motorist shall not be in violation if the device is contained in a locked, opaque box or similar container or the device is not in the passenger compartment of the vehicle and is not in operation.

Violation of this law is a petty offense with a minimum fine of \$50 for a first offense and a minimum \$100 for a second or subsequent offense.

## Section 2: Driving Safely

This section contains knowledge and safe driving information that all commercial drivers should know. You must take an exam on this information to obtain a CDL. This section does NOT include specific information on air brakes, combination vehicles, doubles or passenger vehicles. You must read other sections of this manual to learn about them.

This section also includes basic information on hazardous materials (HazMat) that all drivers should know. If you need a HazMat Endorsement, please study Section 9.

### 2.1 Vehicle Inspections

The most important aspect of traffic safety for yourself and others who share the road with you **is that you personally inspect your vehicle**. A vehicle defect found during an inspection could save you problems later. You could have a breakdown on the road that will cost you time and money, or even worse, an accident caused by the defect.

Federal and state laws require that drivers inspect their vehicles. Federal and state inspectors also may inspect your vehicles. If they judge a vehicle to be unsafe, they will put it “out of service” until it is repaired.

**Pre-trip Inspection** — A pre-trip inspection will help you find problems that could cause an accident or breakdown.

**Trip Inspection** — For safety you should:

- Watch gauges for signs of trouble.
- Use your senses to check for problems (look, listen, smell, feel).
- Check critical items when you stop:
  - Tires, wheels and rims
  - Brakes
  - Lights and reflectors
  - Brake and electrical connections to trailer
  - Trailer coupling devices
  - Cargo securement devices

**After-Trip Inspection and Report** — Conduct an after-trip inspection at the end of the trip, day or tour of duty on each vehicle you operate. This may include completing a **vehicle condition report** listing any problems you find. The inspection report helps the motor carrier know when the vehicle needs repairs.

**Inspection Checklist** —

**Tires:**

- Too much or too little air pressure.
- Bad wear. You need at least 4/32-inch tread depth in every major groove on front wheels and 2/32-inch depth on other tires. No fabric should show through the tread or sidewall.
- Cuts or other damage.
- Tread separation.
- Dual tires that come in contact with each other or parts of the vehicle.
- Mismatched sizes.
- Radial and bias-ply tires used together.
- Cut or cracked valve stems.
- Regrooved, recapped or retreaded tires on the front wheels of a bus are prohibited.

**Wheels and rims:**

- Damaged rims.
- Rust around wheel nuts may mean the nuts are loose—check tightness. After a tire has been changed, stop a short while later and re-check tightness of nuts.
- Missing clamps, spacers, studs or lugs means danger.
- Mismatched, bent or cracked lock rings are dangerous.
- Wheels or rims that have had welding repairs are not safe.

**Brake drums or shoes:**

- Cracked drums.
- Shoes or pads with oil, grease or brake fluid on them.
- Shoes worn dangerously thin, missing or broken.

**Steering system (See Figure 2-1):**

- Missing nuts, bolts, cotter keys or other parts.
- Bent, loose or broken parts, such as steering column, steering gear box or tie rods.
- If power steering equipped—check hoses, pumps and fluid level for leaks.
- Steering wheel play of more than 10 degrees (approximately 2 inches movement at the rim of a 20-inch steering wheel) can make it hard to steer.

**Figure 2-1**  
**Steering System Key Parts**

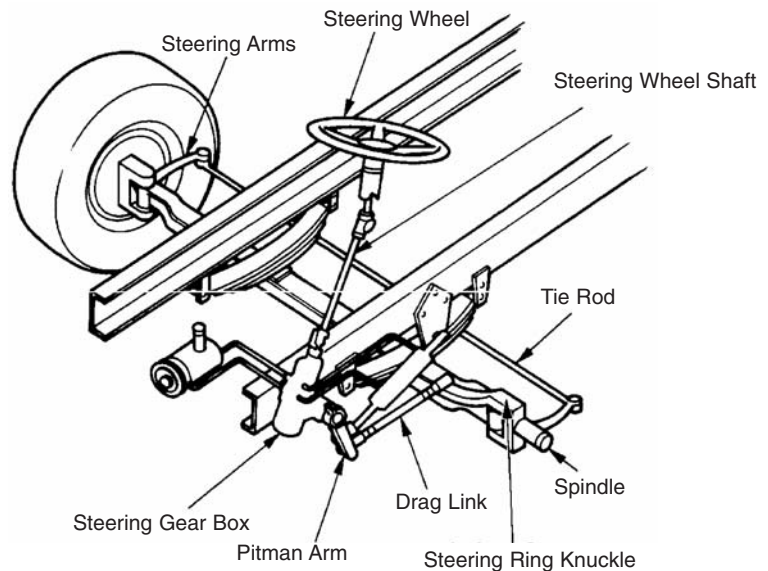

**Suspension systems:** The suspension system holds up the vehicle and its load and keeps the axles in place. Therefore, broken suspension parts can be extremely dangerous. Look for the following:

- Spring hangers (Figure 2-2) that allow movement of axle from proper position.
- Cracked or broken spring hangers.
- Missing or broken leaves in any leaf spring. If 1/4 or more are missing, it will put the vehicle “out of service,” but any defect can be dangerous (Figure 2-3).
- Broken leaves in a multi-leaf spring, or leaves that have shifted so they might hit a tire or other part.
- Leaking shock absorbers (Figure 2-4).
- Torque rod or arm, U-bolts, spring hangers, or other axle positioning parts that are cracked, damaged or missing (Figure 2-2).
- Air suspension systems that are damaged and/or leaking (Figure 2-4).
- Any loose, cracked, broken or missing frame members.

**Exhaust system:** A broken exhaust system can let poisonous fumes into the cab or sleeper berth. Look for the following:

- Loose, broken or missing exhaust pipes, mufflers, tailpipes or vertical stacks.
- Loose, broken or missing mounting brackets, clamps, bolts or nuts.
- Exhaust system parts rubbing against fuel system parts, tires or other moving parts of vehicle.
- Exhaust system parts that are leaking.

**Emergency Equipment** — Vehicles should be equipped with the following emergency equipment:

- Fire extinguisher(s)
- Spare electrical fuses (unless equipped with circuit breakers)
- Warning devices for parked vehicles (e.g., three reflective warning triangles)



**Figure 2-2**  
**Key Suspension Parts**

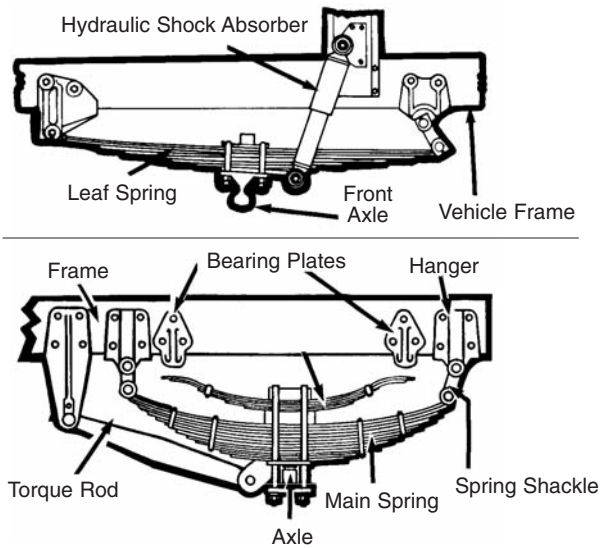

**Figure 2-3**  
**Safety Defect Broken Leaf in Leaf Spring**

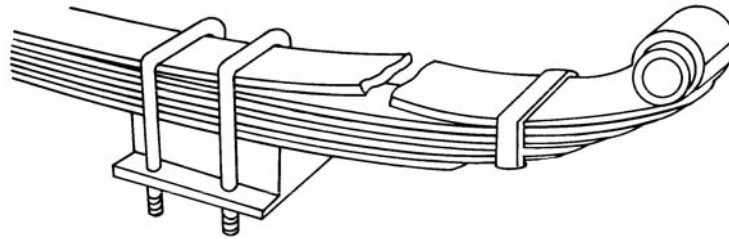

**Figure 2-4**  
**Air Suspension Parts**

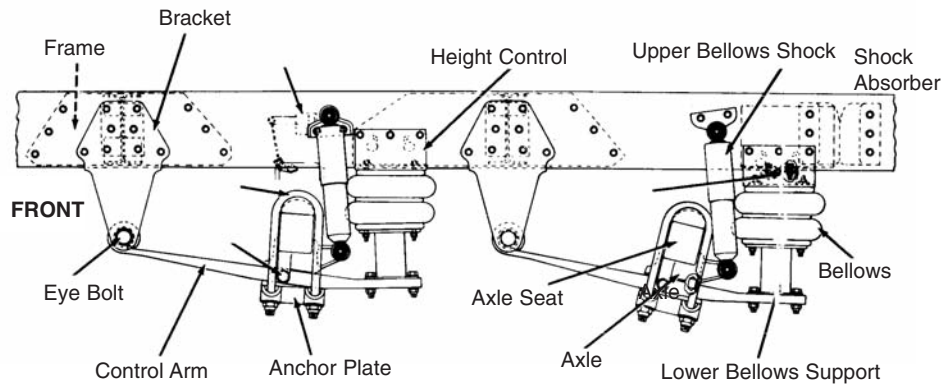

**Cargo (trucks):** Make sure the truck is not overloaded and the cargo is balanced and secured before each trip. If the cargo contains hazardous materials, you must inspect for proper papers and placarding.

**CDL Pre-Trip Inspection Test** — To obtain a CDL you must pass a pre-trip vehicle inspection test. You will be tested to see if you know whether your vehicle is safe to drive. You may be asked to do a pre-trip inspection of your vehicle and explain to the examiner what you would inspect and why. Section 10 describes what to inspect and how to inspect it. Some states allow the guides on pages 17-18 to be used as a memory aid when taking your test.

**7-Step Inspection Method** — You should do a pre-trip inspection the same way each time so you learn all the steps and are less likely to forget something. The 7-Step Inspection Method on the following pages should be useful. (See Figures 2-5, 2-6 and 2-7 on pages 17-18.)

## STEP 1: Vehicle Overview

**Approaching the vehicle:** Notice its general condition. Look for damage or vehicle leaning to one side. Look under the vehicle for fresh oil, coolant, grease or fuel leaks. Check the area around the vehicle for hazards to vehicle movement (people, other vehicles, objects, low hanging wires, limbs, etc.).

**Review last vehicle inspection report:** Drivers may have to make a vehicle inspection report in writing each day. The motor carrier must repair any items in the report that affect safety and certify on the report that repairs were made or were unnecessary. You must sign the report only if defects were noted and certified to be repaired or not needed to be repaired.

### Test Your Knowledge

1. What is the most important reason for doing a vehicle inspection?
2. What things should you check during a trip?
3. Name some key steering system parts.
4. Name some suspension system defects.
5. What three kinds of emergency equipment must you have?
6. What is the minimum tread depth for front tires?
7. For other tires?

**These questions may be on the written exam.  
If you cannot answer all of them, study Section 2: Driving Safely.**

## STEP 2: Check Engine Compartment

**Check that parking brakes are on and/or wheels are chocked:** You may have to raise the hood, tilt the cab (secure loose things so they do not fall and break something), or open the engine compartment door. Check the following:

- Engine oil level
- Coolant level in radiator; condition of hoses
- Power steering fluid level; hose condition (if equipped)
- Windshield washer fluid level
- Battery fluid level, connections and tiedowns (battery may be located elsewhere)
- Automatic transmission fluid level (may require engine to be running)
- Check belts for tightness and excessive wear (alternator, water pump, air compressor)—learn how much “give” the belts should have when adjusted right, and check each one.
- Leaks in the engine compartment (fuel, coolant, oil, power steering fluid, hydraulic fluid, battery fluid).
- Cracked, worn electrical wiring insulation.

Lower and secure hood, cab or engine compartment door.

## STEP 3: Start Engine and Inspect Inside Cab

### Get in and start engine:

- Make sure parking brake is on.
- Put gearshift in neutral (or Park if automatic).
- Start engine; listen for unusual noises.

### Look at gauges:

- **Oil pressure** – Should come up to normal within seconds after engine is started.
- **Ammeter and/or voltmeter** – Should be in normal range(s).
- **Coolant temperature** – Should begin gradual rise to normal operating range.
- **Engine oil temperature** – Should begin gradual rise to normal operating range.
- **Warning lights and buzzers** – Oil, coolant, charging circuit warning lights should go out right away.

# Vehicle Inspection Memory Aids

(Key locations to inspect)

**Figure 2-5**  
**Straight Truck/School Bus**

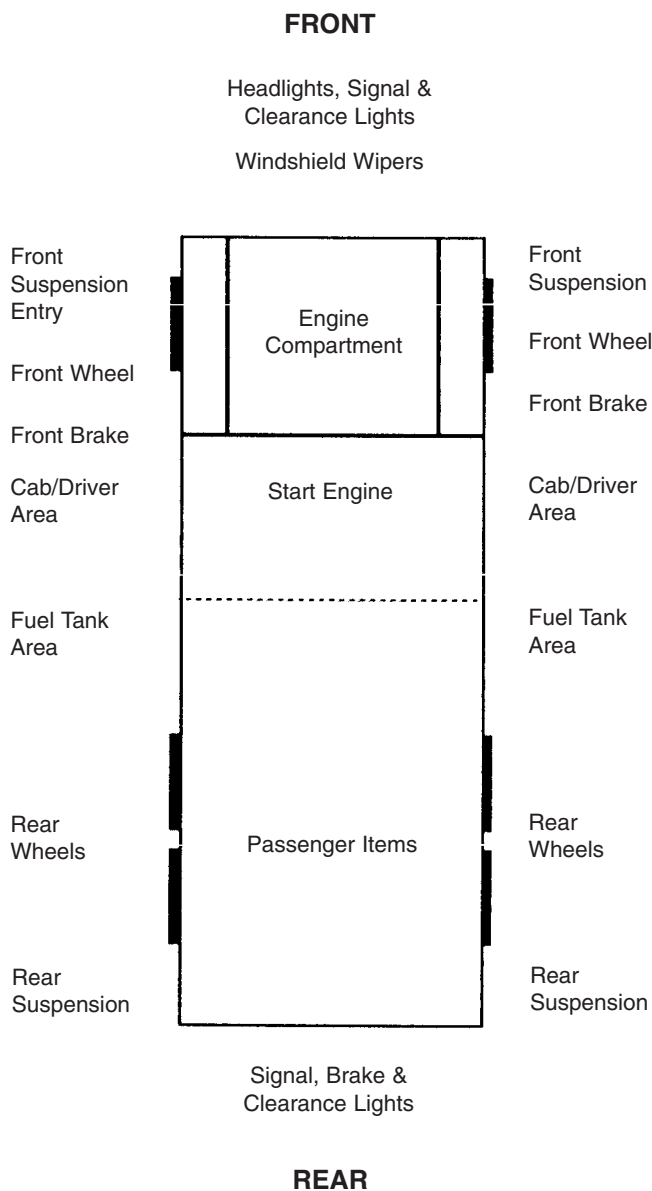

**Figure 2-6**  
**Coach/Transit Bus**

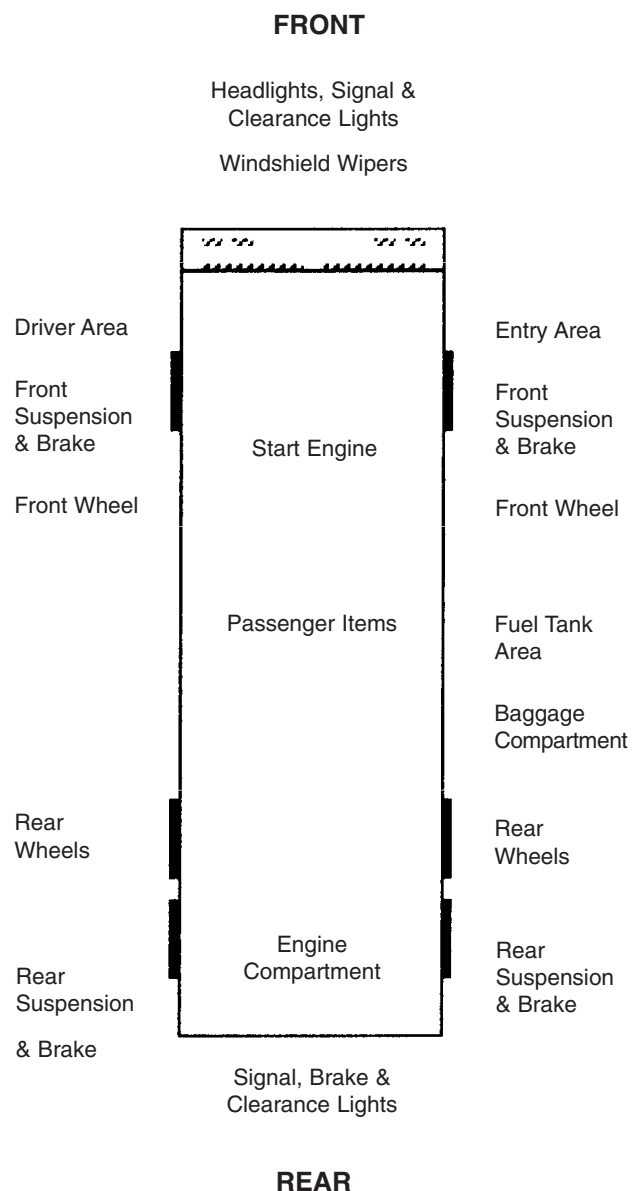

**Safety Note:** Always put the vehicle key in your pocket to prevent someone from moving the vehicle while you are checking underneath it.

# Vehicle Inspection Guide

(Key locations to inspect)

Figure 2-7  
Tractor-Trailer/Transit Bus

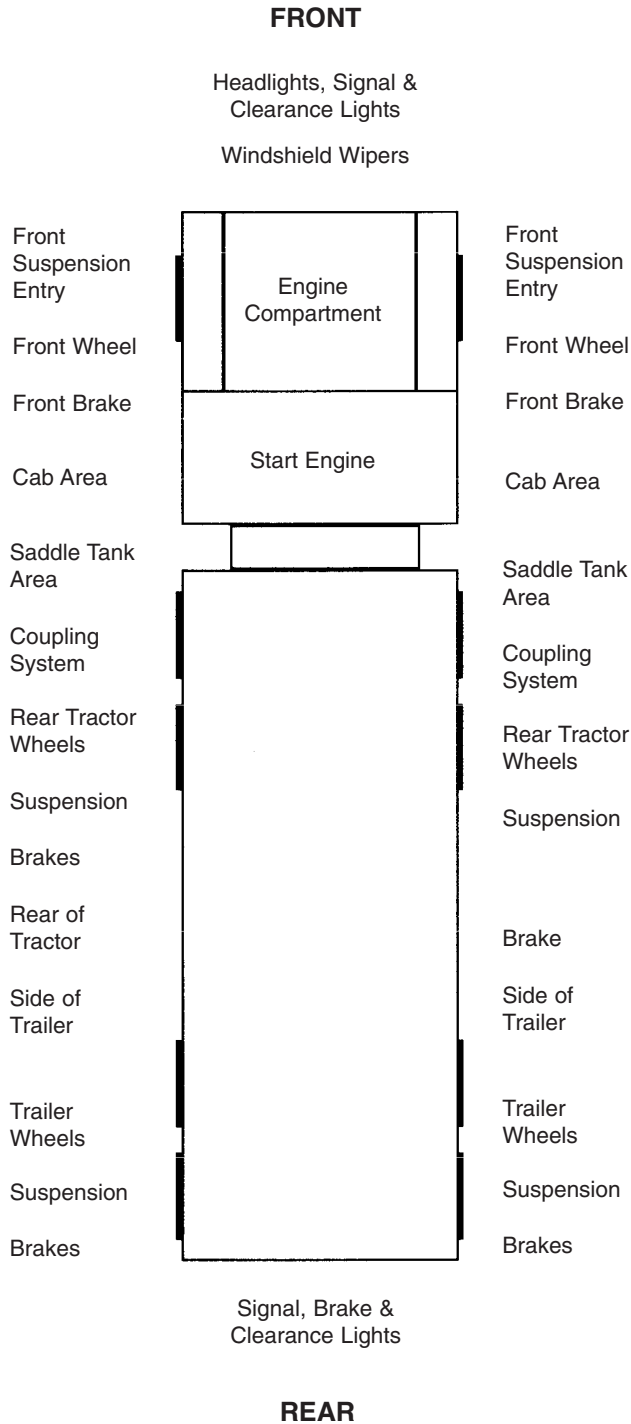

**Safety Note:** If you are parked on a street, walk around so you are facing oncoming traffic. Pay attention to avoid being hit by another motorist.

**Check condition of controls:** Check the following controls for looseness, sticking, damage or improper setting:

- Steering wheel
- Clutch
- Accelerator (gas pedal)
- Brake controls:
  - Foot brake
  - Trailer brake (if equipped)
  - Parking brake
  - Retarder controls (if equipped)
- Transmission controls
- Interaxle differential lock (if equipped)
- Horn(s)
- Windshield wiper/washer
- Lights:
  - Headlights
  - Dimmer switch
  - Turn signal
  - Four-way flashers
  - Clearance, identification, marker light switch(es)

**Check mirrors and windshield:** Inspect mirrors and windshield for cracks, dirt, illegal stickers or other obstructions to vision. Clean and adjust as necessary.

**Check emergency equipment:**

- Check for safety equipment:
  - Spare electrical fuses (unless vehicle has circuit breakers)
  - Three red reflective triangles
  - Properly charged and rated fire extinguisher
- Check for optional items:
  - Tire chains (where winter conditions require them)
  - Tire-changing equipment
- List of emergency phone numbers
- Accident-reporting kit (packet)

**STEP 4: Turn Off Engine and Check Lights**

Make sure the parking brake is set, turn off the engine, and take the key with you. Turn on headlights (low beams) and four-way flashers, and get out.

- Go to front of vehicle and check that low beams are on and both of the four-way flashers are working.
- Push dimmer switch and check that high beams work.
- Turn off headlights and four-way hazard warning flashers.
- Turn on parking, clearance, side-marker and identification lights.
- Turn on right turn signal, and start walk-around inspection.

**STEP 5: Perform Walk-around Inspection**

**General:**

- Walk around and inspect.
- Clean all lights, reflectors and glass as you go along.

**Left front side:**

- Driver's door glass should be clean.
- Door latches or locks work properly.
- Left front wheel:
  - Condition of wheel and rim—missing, bent, broken studs, clamps, lugs, any signs of misalignment.
  - Condition of tires—properly inflated, valve stem and cap OK, no serious cuts, bulges, tread wear.
  - Use wrench to test rust-streaked lug nuts, indicating looseness.
  - Hub oil level OK, no leaks.

- Left front suspension:
  - Condition of spring, spring hangers, shackles, u-bolts.
  - Shock absorber condition.
- Left front brake:
  - Condition of brake drum.
  - Condition of hoses.

**Front:**

- Condition of front axle.
- Condition of steering system.
  - No loose, worn, bent, damaged or missing parts.
  - Must grab steering mechanism to test for looseness.
  - Condition of windshield.
  - Check for damage and clean if dirty.
  - Check windshield wiper arms for proper spring tension.
  - Check wiper blades for damage, “stiff” rubber and securement.
- Lights and reflectors:
  - Parking, clearance and identification lights clean, operating and proper color (amber at front).
  - Reflectors clean and proper color (amber at front).
- Right front turn signal light clean, operating and proper color (amber or white on signals facing forward).

**Right side:**

- Right front: Check all items as done on left front.
- Primary and secondary safety cab locks engaged (if cab-over-engine design).
  - Right fuel tank(s):
    - Securely mounted, not damaged or leaking.
    - Fuel crossover line secure.
    - Tank(s) contain enough fuel.
    - Cap(s) on and secure.
- Condition of visible parts:
  - Rear of engine—not leaking.
  - Transmission—not leaking.
  - Exhaust system—secure, not leaking, not touching wires, fuel or air lines.
  - Frame and cross members—no bends, cracks.
  - Air lines and electrical wiring—secured against snagging, rubbing, wearing.
  - Spare tire carrier or rack not damaged (if equipped).
  - Spare tire and/or wheel securely mounted in rack.
  - Spare tire and wheel adequate (proper size, properly inflated).
- Cargo securement (trucks):
  - Cargo properly blocked, braced, tied, chained, etc.
  - Header board adequate, secure (if required).
  - Side boards, stakes strong enough, free of damage, properly set in place (if equipped).
  - Canvas or tarp (if required) properly secured to prevent tearing, billowing or blocking of mirrors.
  - If oversize, all required signs (flags, lamps, reflectors) must be safely and properly mounted and all required permits in driver’s possession.
  - Curbside cargo compartment doors securely closed, latched/locked; required security seals in place

**Right rear:**

- Condition of wheels and rims—no missing, bent, broken spacers, studs, clamps, lugs.
- Condition of tires—properly inflated, valve stems and caps OK, no serious cuts, bulges, tread wear, tires not rubbing each other and nothing stuck between them.
- Tires same type (i.e., not mixed radial and bias types).
- Tires evenly matched (same sizes).
- Wheel bearing/seals not leaking.

- Suspension:
  - Condition of spring(s), spring hangers, shackles and U-bolts
  - Axle secure.
  - Powered axle(s) not leaking lube (gear oil).
  - Condition of torque rod arms, bushings.
  - Condition of shock absorber(s).
  - If retractable axle-equipped, check condition of lift mechanism; if air-powered, check for leaks.
- Brakes:
  - Brake adjustment.
  - Condition of brake drum(s).
  - Condition of hoses—look for any wear due to rubbing.
- Lights and reflectors:
  - Side-marker lights clean, operating and proper color (red at rear, others amber).
  - Side-marker reflectors clean and proper color (red at rear, others amber).

#### **Rear:**

- Lights and reflectors:
  - Rear clearance and identification lights clean, operating and proper color (red at rear).
  - Reflectors clean and proper color (red at rear).
  - Taillights clean, operating and proper color (red at rear).
  - Right rear turn signal operating and proper color (red, yellow, or amber at rear).
- License plate(s) present, clean and secured.
- Splash guards present, not damaged, properly fastened, not dragging on ground or rubbing tires.
- Cargo secure (trucks):
  - Cargo properly blocked, braced, tied, chained, etc.
  - Tailboards up and properly secured.
  - End gates free of damage, properly secured in stake sockets.
  - Canvas or tarp (if required) properly secured to prevent tearing, billowing to block either the rearview mirrors or to cover rear lights.
  - If over-length, or over-width, make sure all signs and/or additional lights/flags are safely and properly mounted and all required permits are in driver's possession.
  - Rear doors securely closed, latched/locked.

#### **Left side:**

Check all items as done on right side, plus:

- Battery(s) (if not mounted in engine compartment).
- Battery(s) box securely mounted to vehicle.
- Box has secure cover.
- Battery(s) secured against movement.
- Battery(s) not broken or leaking.
- Fluid in battery(s) at proper level (except maintenance-free type).
- Cell caps present and securely tightened (except maintenance-free type).
- Vents in cell caps free of foreign material (except maintenance-free type).

### **STEP 6: Check Lights**

#### **Get in and turn off lights:**

- Turn off all lights.
- Turn on stop lights (apply trailer hand brake or have someone press the brake pedal).
- Turn on left turn signal lights.

#### **Get out and check lights:**

- Left front turn signal light clean, operating and proper color (amber or white on signals facing the front).
- Left rear turn signal light and both stop lights clean, operating and proper color (red, yellow or amber).

**Get in vehicle:**

- Turn off lights not needed for driving.
- Check for all required papers, trip manifests, permits, etc.
- Secure all loose articles in cab. (They might interfere with operation of the controls or hit you in a crash.)
- Start the engine.

**STEP 7: Start Engine and Check Brake System****Test for hydraulic leaks:**

- If the vehicle has hydraulic brakes, pump the brake pedal three times. Then apply firm pressure to the pedal and hold for five seconds. The pedal should not move. If it does, there may be a leak or other problem. Get it fixed before driving.

**If the vehicle has air brakes, do the checks described in Sections 5 and 6.**

**Test parking brake:**

- Fasten safety belt.
- Allow vehicle to move forward slowly.
- Apply parking brake.
- If it doesn't stop vehicle, it is faulty; get it fixed.

**Test service brake stopping action:**

- Go about 5 mph.
- Push brake pedal firmly.
- "Pulling" to one side or the other can mean brake trouble.
- Any unusual brake pedal "feel" or delayed stopping action may mean trouble.

**If you find anything unsafe during the pre-trip inspection, get it repaired immediately. Federal and state laws prohibit operating an unsafe vehicle.**

**Trip Inspection** — Check the following regularly:

- Instruments
- Air-pressure gauge (if you have air brakes)
- Temperature gauges
- Pressure gauges
- Ammeter/voltmeter
- Mirrors
- Tires
- Cargo, cargo covers

If you see, hear, smell or feel anything that might mean trouble, check it out.

**After-trip Inspection** — Drivers of trucks and truck tractors when transporting cargo must inspect the securement of the cargo within the first 25 miles of a trip and every 150 miles or every three hours (whichever comes first) afterward.

You may have to make a written report each day on the condition of the vehicle(s) you drove. Report anything affecting safety or possibly leading to mechanical breakdown.

The vehicle inspection report tells the motor carrier about problems that may need to be fixed. Keep a copy of your report in the vehicle for one day so the next driver will be aware of any problems you have found.



## Test Your Knowledge

1. Name some things you should check on the front of your vehicle during the walk-around inspection.
2. What should wheel bearing seals be checked for?
3. How many red reflective triangles should you carry?
4. How do you test hydraulic brakes for leaks?
5. Can you bring the Vehicle Inspection Memory Aids with you to the exam?
6. Why put the starter switch key in your pocket during the pre-trip inspection?

**These questions may be on the written exam.  
If you cannot answer all of them, study the 7-Step Inspection Method.**

## 2.2 Basic Control of Your Vehicle

To drive a vehicle safely, you must be able to control its speed and direction. Safe operation of a commercial vehicle requires skills in:

- Accelerating
- Steering
- Shifting gears
- Braking

Fasten your safety belt when on the road. Apply the parking brake when you leave your vehicle.

Do not roll back when you start. You may hit someone behind you. Partly engage the clutch before you take your right foot off the brake. Put on the parking brake whenever necessary to keep from rolling back. Release the parking brake only when you have applied enough engine power to keep from rolling back. On a tractor-trailer equipped with a trailer brake hand valve, the hand valve can be applied to keep from rolling back.

**Accelerating** — Speed up smoothly and gradually so the vehicle does not jerk. Rough acceleration can cause mechanical damage. When pulling a trailer, rough acceleration can damage the coupling.

Speed up very gradually when traction is poor, as in rain or snow. If you use too much power, the drive wheels may spin. You could lose control. If the drive wheels begin to spin, take your foot off the accelerator.

**Steering** — Hold the steering wheel firmly with both hands. Your hands should be on opposite sides of the wheel. If you hit a curb or a pothole (chuckhole), the wheel could pull away from your hands unless you have a firm hold.

**Backing Safely** — Because you cannot see everything behind your vehicle, backing is always dangerous. Avoid backing whenever you can. Park so you will be able to pull forward when you leave. When you have to back, follow these safety rules:

- **Look at your path** – Look at your line of travel before you begin. Get out and walk around the vehicle. Check your clearance to the sides and overhead in and near the path your vehicle will take.
- **Back slowly** – Always back as slowly as possible. Use the lowest reverse gear so you can more easily correct any steering errors. You also can stop quickly if necessary.
- **Back and turn toward driver's side** – Back to the driver's side so you can see better. Backing toward the right side is very dangerous because you cannot see as well. If you back and turn toward the driver's side, you can watch the rear of your vehicle by looking out the side window. Use driver-side backing—even if it means going around the block to put your vehicle in this position. The added safety is worth it.
- **Use a helper** – Use a helper when you can. There are blind spots you cannot see. The helper should stand near the back of your vehicle where you can see the helper. Before you begin backing, work out a set of hand signals that you both understand. Agree on a signal for “stop.”

When backing a car, straight truck or bus, turn the top of the steering wheel toward the direction you want to go. When backing a trailer, turn the steering wheel **in the opposite direction**. Once the trailer starts to turn, you must turn the wheel the other way to follow the trailer.

**Backing with a Trailer** — When you back with a trailer, try to position your vehicle so you can back in a straight line. If you must back on a curved path, back to the driver's side so you can see.

- **Back slowly** – This will let you make corrections before you get too far off course.
- **Use the mirrors** – The mirrors will help you see whether the trailer is drifting to one side or the other.
- **Correct drift immediately** – As soon as you see the trailer getting off the proper path, correct it by turning the top of the steering wheel in the direction of the drift.
- **Pull forward** – When backing a trailer, make pull-ups to reposition your vehicle as needed.

### Test Your Knowledge

1. Why should you back toward the driver's side?
2. What is pull-up?
3. If stopped on a hill, how can you start moving without rolling back?
4. When backing, why is it important to use a helper?
5. What is the most important hand signal you and the helper should agree on?

**These questions may be on the written exam.  
If you cannot answer all of them, study Section 2.2**

## 2.3 Shifting Gears

**Manual Transmissions** — Correct shifting of gears is important. If you cannot get your vehicle into the right gear while driving, you will have less control. Most heavy vehicles with manual transmissions require double clutching to change gears.

### Basic method for shifting up:

1. Release accelerator, push in clutch and shift to neutral at the same time.
2. Release clutch.
3. Let engine and gears slow down to the RPM required for the next gear (this takes practice).
4. Push in clutch and shift to the higher gear at the same time.
5. Release clutch and press accelerator at the same time.

Shifting gears using double clutching requires practice. If you remain too long in neutral, you may have difficulty putting the vehicle into the next gear. If so, do not try to force it. Return to neutral, release clutch, increase engine speed to match road speed, and try again.

### Knowing when to shift up:

1. **Use engine speed (RPM)** – Study the driver's manual for your vehicle and learn the operating RPM range. Watch your tachometer, and shift up when your engine reaches the top of the range. (Some newer vehicles use "progressive" shifting: the RPM at which you shift becomes higher as you move up in the gears. Find out what's right for the vehicle you will operate.)
2. **Use road speed (mph)** – Learn what speeds each gear is good for. Then, by using the speedometer, you will know when to shift up.

With either method, you may learn to use engine sounds to know when to shift.

### Basic method for shifting down:

1. Release accelerator, push in clutch and shift to neutral at the same time.
2. Release clutch.
3. Press accelerator, **increase** engine and gear speed to the RPM required in the lower gear.
4. Push in clutch and shift to lower gear at the same time.
5. Release clutch and press accelerator at the same time.

Downshifting, like upshifting, requires knowing when to shift. Use either the tachometer or the speedometer and downshift at the right RPM or road speed.

Special conditions where you should downshift are:

1. **Before starting down a hill** – Slow down and shift down to a speed that you can control without using the brakes hard. Otherwise the brakes can overheat and lose their braking power. Downshift before starting down the hill. Make sure you are in a low enough gear, usually lower than the gear required to climb the same hill.
2. **Before entering a curve** – Slow down to a safe speed, and downshift to the right gear before entering the curve. This lets you use some power through the curve to help the vehicle be more stable while turning. It also lets you speed up as soon as you are out of the curve.

**Multi-Speed Rear Axles and Auxiliary Transmissions** — Multi-speed rear axles and auxiliary transmissions are used on many vehicles to provide extra gears. You usually control them by a selector knob or switch on the gearshift lever of the main transmission. There are many different shift patterns. Learn the right way to shift gears in the vehicle you will drive.

**Automatic Transmissions** — Some vehicles have automatic transmissions. You can select a low range to get greater engine braking when going down grades. The lower ranges prevent the transmission from shifting up beyond the selected gear (unless the governor RPM is exceeded). It is very important to use this braking effect when going down grades.

**Retarders** — Some vehicles have “retarders,” which help slow a vehicle and reduces the need for using the brakes. They reduce brake wear and give you another way to slow down. There are many types of retarders (exhaust, engine, hydraulic, electric). All retarders can be turned on or off by the driver. On some the retarding power can be adjusted. When turned “on,” retarders apply their braking power (to the drive wheels only) whenever you let up on the accelerator pedal all the way.

**Caution:** When your drive wheels have poor traction, the retarder may cause them to skid. Therefore, you should turn the retarder off whenever the road is wet, icy or snow covered. report in the vehicle for one day so the next driver will be aware of any problems you have found.

### Test Your Knowledge

1. What are the two special conditions where you should downshift?
2. When should you downshift automatic transmissions?
3. Retarders keep you from skidding when the road is slippery. True or False?
4. What are the two ways to know when to shift?

**These questions may be on the written exam.  
If you cannot answer all of them, study Section 2.3.**

## 2.4 Seeing

To be a safe driver you need to know what’s going on all around your vehicle. Not looking properly is a major cause of accidents.

**Seeing Ahead** — All drivers look ahead, but many do not look **far enough** ahead. Because stopping or changing lanes can take a lot of distance, knowing what the traffic is doing on all sides of you is very important. You need to look well ahead to make sure you have room to make these moves safely.

- Most good drivers look 12-15 seconds ahead. That means looking ahead the distance you will travel in 12-15 seconds. At lower speeds, that's about one block. At highway speeds it's about one-quarter of a mile. If you are not looking that far ahead, you may have to stop too quickly or make quick lane changes. Looking 12-15 seconds ahead does not mean not paying attention to things that are closer. Good drivers shift their attention back and forth, near and far.
- Look for vehicles coming onto the highway, into your lane, or turning. Watch for brake lights from slowing vehicles. By seeing these things far enough ahead, you can change your speed or change lanes if necessary to avoid a problem.
- Look for hills and curves, anything for which you will have to slow or change lanes. Pay attention to traffic signals and signs. If a light has been green for a long time, it will probably change before you get there. Start slowing down and be ready to stop. Traffic signs may alert you to road conditions where you may have to change speed.

**Seeing to the Side and Rear** — It is important to know what is going on behind and to the sides. Check your mirrors regularly. Check more often in special situations.

#### **Using/adjusting mirrors:**

- Check and adjust each mirror prior to the start of any trip and during your trip as needed. Special situations require more than regular mirror checks.
- Mirrors can only be checked accurately when the trailer(s) is straight.
- In traffic check the mirrors for vehicles on either side and in back of you. In an emergency, you may need to know whether you can make a quick lane change.
- Use your mirrors to spot overtaking vehicles. There are “blind spots” that your mirrors cannot show you. Check your mirrors regularly to know where other vehicles are around you, and to see if they move into your blind spots.
- Use the mirrors to keep an eye on your tires. It is one way to spot a tire fire. If you are carrying open cargo, you can use the mirrors to check it. Look for loose straps, ropes or chains. Watch for a flapping or ballooning tarp.
- Check quickly when driving on the road. Look back and forth between the mirrors and the road ahead. Do not focus on the mirrors for too long. Otherwise, you will travel quite a distance without knowing what is happening ahead.
- Understand what you see. Many large vehicles have curved (convex, “fisheye,” “spot,” “bugeye”) mirrors that show a wider area than flat mirrors. This is often helpful, but be aware that everything appears smaller in a convex mirror than it would if you were looking at it directly. Things also seem farther away than they really are. It is important to realize this and to allow for it.
- When changing lanes check your mirrors to make sure no one is alongside you or about to pass you. Check your mirrors:
  - Before you change lanes to make sure there is enough room.
  - After you have signaled to check that no one has moved into your blind spot.
  - Right after you start the lane change to double-check that your path is clear.
  - After you complete the lane change.
- When turning, check your mirrors to make sure the rear of your vehicle will not hit anything.
- When merging, use your mirrors to make sure the gap in traffic is large enough for you to enter safely.
- Any time you are driving in close quarters, check your mirrors often. Make sure you have enough clearance.

## **2.5 Communicating**

Other drivers will not know what you are going to do until you communicate your intentions.

#### **Using Turn Signals —**

- Signal early. Signal well before you turn. It is the best way to keep others from trying to pass you.
- Signal continuously. You need both hands on the wheel to turn safely. Do not cancel the signal until you have completed the turn.
- Do not forget to turn off your turn signal after you have turned (if you do not have self-cancelling signals).
- Use your turn signal when changing lanes. Change lanes slowly and smoothly. A driver you did not see may have a chance to honk his/her horn or avoid your vehicle.

#### **Using Lights and Horn —**

- **Slowing down** – If you need to slow down, warn drivers behind you with a few light taps on the brake pedal — enough to flash the brake lights. Use the four-way emergency flashers when you are driving very slow or are stopped.
- **Tight turns** – Most car drivers do not know how slow you have to go to make a tight turn in a large vehicle. Give drivers behind you warning by braking early and slowing gradually.

- **Stopping on the road** – Truck and bus drivers sometimes stop in the road to unload cargo or passengers or to stop at a railroad crossing. Warn following drivers by flashing your brake lights. Do not stop suddenly.
- **Driving slowly** – Drivers often do not realize how fast they are catching up to a slow vehicle until they are very close. If you must drive slowly, alert following drivers by turning on your emergency flashers if it is legal. (Laws regarding the use of flashers differ from one state to another. Check the laws of the states where you will drive.)
- **Passing** – When you are about to pass a vehicle, pedestrian or bicyclist, assume they do not see you. They could suddenly move in front of you. When it is legal, tap the horn lightly or, at night, flash your lights from low- to high-beams and back. And drive carefully enough to avoid a crash even if they do not see or hear you. Some drivers try to help out others by signaling when it is safe to pass. You should not do this. You could cause an accident, you could be blamed, and it could cost you thousands of dollars.
- **Being seen** – At dawn or dusk or in rain or snow, make your vehicle easier to be seen by turning on your low-beam headlights. If you are having trouble seeing other vehicles, other drivers will have trouble seeing yours.
- **Parking on side of road** – When you pull off the road and stop, turn on the four-way emergency flashers, especially at night. Do not trust the taillights to give warning. Drivers have crashed into the rear of a parked vehicle because they thought it was moving normally. If you must stop on a road or the shoulder of any road, you must put out your emergency warning devices within 10 minutes. Place your warning devices at the following locations:
  - On a two-lane road carrying traffic in both directions or on an undivided highway, place warning devices within 10 feet of the front or rear corners to mark the location of the vehicle and 100 feet behind and ahead of the vehicle, on the shoulder or in the lane you are stopped in (see Figure 2-8 on page 28).
  - Back beyond any hill, curve or other obstruction that prevents other drivers from seeing the vehicle within 500 feet (see Figure 2-9 on page 28).
  - On or by a one-way or divided highway, place warning devices 10 feet, 100 feet and 200 feet toward the approaching traffic (see Figure 2-10 on page 28).

When putting out the triangles, hold them between yourself and the oncoming traffic for your own safety (so other drivers can see you).

- **Use your horn only when needed** – Your horn can let others know you are there and help to avoid a crash. Use your horn when needed; however, it can startle others and could be dangerous when used unnecessarily.

**Figure 2-8**  
**Warning Device Placement:**  
**Two-Lane (traffic in both**  
**directions) or Undivided Highway**

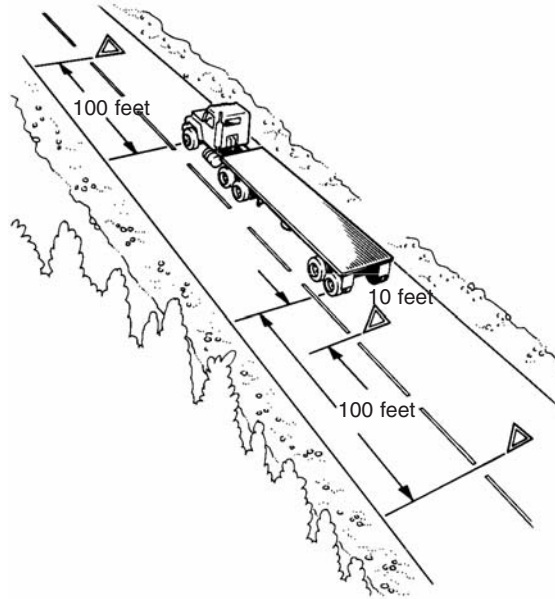

**Figure 2-9**  
**Warning Device Placement:**  
**Obstructed View**

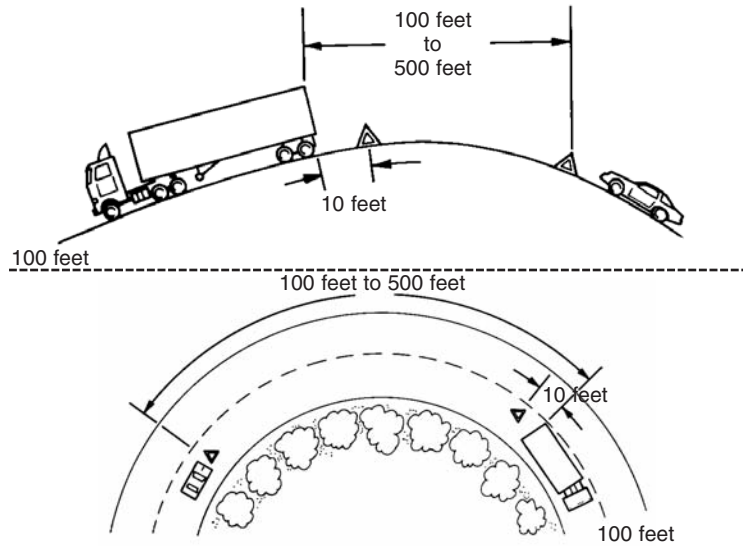

**Figure 2-10**  
**Warning Device Placement:**  
**One-Way or Divided Highway**

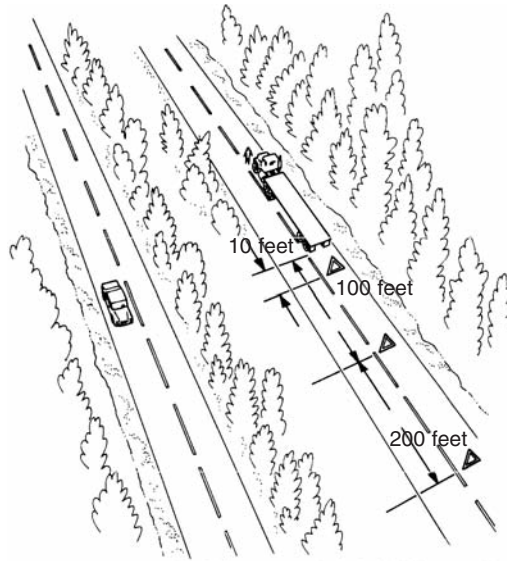

## 2.6 Controlling Speed

Driving too fast is a major cause of fatal crashes. You must adjust your speed depending on driving conditions. These include traction, curves, visibility, traffic and hills.

**Speed and Stopping Distances** — Three things add up to total stopping distance:

$$\begin{array}{r} \text{Perception Distance} \\ + \text{Reaction Distance} \\ + \text{Braking Distance} \\ \hline = \text{Total Stopping Distance} \end{array}$$

- **Perception distance** is the distance your vehicle travels from the time your eyes see a hazard until your brain recognizes it. The perception time for an alert driver is about 3/4 second. At 55 mph, you travel 60 feet in 3/4 second.
- **Reaction distance** is the distance traveled from the time your brain tells your foot to move from the accelerator until your foot is actually pushing the brake pedal. The average driver has a reaction time of 3/4 second. This accounts for an additional 60 feet traveled at 55 mph.
- **Braking Distance** is the distance it takes to stop once the brakes are applied. At 55 mph on dry pavement with good brakes, it can take a heavy vehicle about 170 feet and about 4 1/2 seconds to stop.
- **Total stopping distance** – At 55 mph it will take about 6 seconds to stop and your vehicle will travel the distance of a football field (60 + 60 + 170 = 290 feet).

**Effect of speed on stopping distance:** Whenever you double your speed, it takes about **four** times as much distance to stop, and your vehicle will have **four** times the destructive power if it crashes. High speeds increase stopping distances greatly. By slowing down a little, you can gain a lot in reduced braking distance.

**Effect of vehicle weight on stopping distance:** The heavier the vehicle, the more work the brakes must do to stop it and the more heat they absorb. But the brakes, tires, springs and shock absorbers on heavy vehicles are designed to work best when the vehicle is fully loaded. **Empty** trucks require **greater** stopping distances, because an empty vehicle has less traction. It can bounce and lock up its wheels, giving much poorer braking. (This is not usually the case with buses.)

**Matching Speed to Road Surface** — You cannot steer or brake a vehicle unless you have traction. Traction is friction between the tires and the road. There are some road conditions that reduce traction and call for lower speeds.

**Slippery surfaces:** It will take longer to stop and be harder to turn without skidding when the road is slippery. You must drive slower to be able to stop in the same distance as on a dry road. Wet roads can double stopping distance. Reduce speed by about one-third (e.g., slow from 55 to 35 mph) on a wet road. On packed snow, reduce speed by half or more. If the surface is icy, reduce speed to a crawl and stop driving as soon as you can safely do so.

Sometimes it is hard to know if the road is slippery. Following are signs of slippery roads:

- **Shaded areas** – Shady parts of the road will remain icy and slippery long after open areas have melted.
- **Bridges** – When the temperature drops, bridges will freeze before the road will. Be especially careful when the temperature is close to 32 degrees F.
- **Melting ice** – Slight melting will make ice wet. Wet ice is much more slippery than ice that is not wet.
- **Black ice** – Black ice is a thin layer that is clear enough that you can see the road underneath it. It makes the road look wet. Any time the temperature is below freezing and the road looks wet, watch out for black ice.
- **Vehicle icing** – An easy way to check for ice is to open the window and feel the front of the mirror, mirror support or antenna. If there is ice on them, the road surface is probably starting to ice up.
- **Just after rain begins** – Right after it starts to rain, the water mixes with oil left on the road by vehicles. This makes the road very slippery. If the rain continues, it will wash the oil away.

**Hydroplaning:** In some weather, water or slush collects on the road. When this happens, your vehicle can hydroplane. It is like water skiing: the tires lose contact with the road and have little or no traction. You may not be able to steer or brake. You can regain control by releasing the accelerator and pushing in the clutch. This will slow your vehicle and let the wheels turn freely. If the vehicle is hydroplaning, do not use the brakes to slow down. If the drive wheels start to skid, push in the clutch to let them turn freely.

It does not take a lot of water to cause hydroplaning. Hydroplaning can occur at speeds as low as 30 mph if there is a lot of water. Hydroplaning is more likely if tire pressure is low or the tread is worn. (The grooves in a tire carry away

the water; if they are not deep, they do not work well.) Be especially careful driving through puddles. The water is often deep enough to cause hydroplaning.

**Speed and Curves** — Drivers must adjust their speed for curves in the road. If you take a curve too fast, two things can happen. The wheels can lose their traction and continue straight ahead, so you skid off the road, or the wheels keep their traction and the vehicle rolls over. Tests have shown that trucks with a high center of gravity can roll over at the posted speed limit for a curve.

Slow to a safe speed **before** you enter a curve. Braking in a curve is dangerous because it is easier to lock the wheels and cause a skid. Slow down as needed. Do not exceed the posted speed limit for the curve. Be in a gear that will let you accelerate slightly in the curve. This will help you keep control.

**Speed and Distance Ahead** — You should always be able to stop within the distance you can see ahead. Fog, rain or other conditions may require that you slow down to be able to stop in the distance you can see. At night, you cannot see as far with low-beams as you can with high-beams. When you must use low-beams, slow down.

**Speed and Traffic Flow** — When you are driving in heavy traffic, the safest speed is that of other vehicles. Vehicles going the same direction at the same speed are not likely to run into one another. Drive at the speed of other traffic, if you can without going at an illegal or unsafe speed. Keep a safe following distance.

**Speed on Downgrades** — Your vehicle's speed will increase on downgrades because of gravity. Your most important objective is to select and maintain a speed that is not fast for the:

- Total weight of the vehicle and cargo.
- Length of the grade.
- Steepness of the grade.
- Road conditions.
- Weather.

If a speed limit is posted, or there is a sign indicating "Maximum Safe Speed," never exceed the speed shown. Also, look for and heed warning signs indicating the length and steepness of the grade. You must use the braking effect of the engine as the principal way of controlling your speed on downgrades. The braking effect of the engine is greatest when it is near the governed RPMs and the transmission is in the lower gears. Save your brakes so you will be able to slow or stop as required by road and traffic conditions. Shift your transmission to a low gear **before** starting down the grade and use the proper braking techniques. Please read carefully the section on going down long steep downgrades safely in Mountain Driving on page 38-39.



## Test Your Knowledge

1. How far ahead does the manual say you should look?
2. What are two main things to look for ahead?
3. What is the most important way to see the sides and rear?
4. What does “communicating” mean in safe driving?
5. Where should your reflectors be placed when stopped on a divided highway?
6. What three things add up to stopping distance?
7. If you go twice as fast, will your stopping distance increase by two or four times?
8. Empty trucks have the best braking. True or False?
9. What is hydroplaning?
10. What is “black ice?”

**These questions may be on the written exam.  
If you cannot answer all of them, study Sections 2.4, 2.5 and 2.6.**

## 2.7 Managing Space

To be a safe driver, you need space all around your vehicle. When things go wrong, space gives you time to think and to take action. To have space available when something goes wrong, you need to **manage** space. While this is true for all drivers, it is very important for large vehicles. They take up more space and require more space for stopping and turning.

**Space Ahead** — Of all the space around your vehicle, it is the area ahead of the vehicle—the space you are driving into—that is most important. You need space ahead in case you must suddenly stop. According to accident reports, the vehicle that trucks and buses most often run into is the one in front of them. The most frequent cause is **following too closely**. Remember, if the vehicle ahead of you is smaller than yours, it can probably stop faster than you can. You may crash if you are following too closely.

One good rule for how much space you should keep in front of you is at least 1 second for each 10 feet of vehicle length at speeds below 40 mph. At greater speeds, you must add 1 second for safety. For example, if you are driving a 40-foot vehicle, you should leave 4 seconds between you and the vehicle ahead. In a 60-foot rig, you will need 6 seconds. Over 40 mph, you would need 5 seconds for a 40-foot vehicle and 7 seconds for a 60-foot vehicle.

To know how much space you have, wait until the vehicle ahead passes a shadow on the road, a pavement marking, or some other clear landmark. Then count off the seconds like this: “one thousand-and-one, one thousand-and-two” and so on, until you reach the same spot. Compare your count with the rule of 1 second for every 10 feet of length. If you are driving a 40-foot truck and only counted up to 2 seconds, you are too close. Drop back a little and count again until you have 4 seconds of following distance (or 5 seconds, if you are going over 40 mph). After a little practice, you will know how far back you should be. Remember to add 1 second for speeds above 40 mph. Also remember that when the road is slippery, you need **much more space** to stop.

**Space Behind** — You cannot stop others from following you too closely, but there are things you can do to make it safer:

- **Stay to the right** – Heavy vehicles are often tailgated when they cannot keep up with the speed of traffic. This often happens when you are going uphill. If a heavy load is slowing you down, stay in the right lane if you can. Going uphill, you should not pass another slow vehicle unless you can get around quickly and safely.

- **Handling tailgaters** – In a large vehicle, it is often difficult to see whether a vehicle is close behind you. You may be tailgated:
  - **When you are traveling slowly.** Drivers trapped behind slow vehicles often follow closely.
  - **In bad weather.** Many car drivers follow large vehicles closely during bad weather, especially when it is hard to see the road ahead.

If you are being tailgated, do the following to reduce the chances of an accident:

- **Avoid quick changes.** If you have to slow down or turn, signal early and reduce speed very gradually.
- **Increase your following distance.** Opening up room in front of you will help you avoid having to make sudden speed or direction changes. It also makes it easier for the tailgater to get around you.
- **Do not speed up.** It is safer to be tailgated at a low speed than a high speed.
- **Avoid tricks.** Do not turn on your taillights or flash your brake lights. Follow the suggestions above.

**Space to the Sides** — Commercial vehicles are often wide and take up most of a lane. Safe drivers will manage what little space they have by keeping their vehicle centered in the lane and avoiding driving alongside others.

- **Staying centered in a lane** – Keep your vehicle centered in the lane to maintain safe clearance on either side. If your vehicle is wide, you have little room to spare.
- **Strong winds** – Strong winds can make it difficult to stay in your lane. The problem is usually worse for lighter vehicles. This problem can be especially bad coming out of tunnels. Do not drive alongside others if you can avoid it.
- **Traveling next to others** – There are two dangers in traveling alongside other vehicles. Another driver may change lanes suddenly and turn into you. You may be trapped when you need to change lanes. Find an open spot where you are not near other traffic. When traffic is heavy, it may be hard to find an open spot. If you must travel near other vehicles, try to keep as much space as possible between you and them. Also, drop back or pull forward so you are sure the other driver can see you.

**Space Overhead** — Hitting overhead objects is a danger. Make sure you always have overhead clearance.

- Do not assume that the weights and heights posted at bridges and overpasses are correct. Repaving or packed snow may have reduced the clearances since the heights were posted.
- The weight of a cargo van changes its height. An empty van is higher than a loaded one. That you got under a bridge when you were loaded does not mean that you can do it when you are empty.
- If you doubt you have safe space to pass under an object, go slowly. If you are not sure you can make it, take another route. Warnings are often posted on low bridges or underpasses, but sometimes they are not.
- Some roads can cause a vehicle to tilt. There can be a problem clearing objects along the edge of the road, such as signs or trees or bridge supports. Where this is a problem, drive a little closer to the center of the road.
- Before you back into an area, get out and check for over-hanging objects, such as trees, branches or electrical wires. It is easy to miss seeing them while you are backing. (Also check for other hazards at the same time.)

**Space Below** — Many drivers forget about the space below their vehicles. That space can be very small when a vehicle is heavily loaded. Railroad tracks can stick up several inches. This is often a problem on dirt roads and in unpaved yards where the surface around the tracks can wear away. Do not take a chance on getting hung up halfway across. Drainage channels across roads can cause the end of some vehicles to drag. Cross such depressions carefully.

**Space for Turns** — The space around a truck or bus is important in turns. Because of wide turning and off-tracking, large vehicles can hit other vehicles or objects during turns.

#### Right turns:

- Turn slowly to give yourself and others more time to avoid problems.
- If you are driving a truck or bus that cannot make the right turn without swinging into another lane, **turn wide** as you **complete** the turn, as shown in Figure 2-11 on page 33. **Keep the rear** of your vehicle close to the curb. This will stop other drivers from passing you on the right.
- Do not turn wide to the left as you start the turn, as shown in Figure 2-12 on page 33. A following driver may think you are turning left and try to pass you on the right. You may crash into the other vehicle as you complete your turn.
- If you must cross into the oncoming lane to make a turn, watch out for vehicles coming toward you. Give them room to go by or to stop. However, do not back up for them, because you might hit someone behind you.

#### Left Turns:

- Make sure you have reached the center of the intersection before you start the left turn. If you turn too soon, the left side of your vehicle may hit another vehicle because of off-tracking.
- If there are two turning lanes, always take the right-hand turn lane, as shown in Figure 2-13. Do not start in the inside lane because you may have to swing right to make the turn. Drivers on your left can be more readily seen.

**Figure 2-11**  
Correct turning

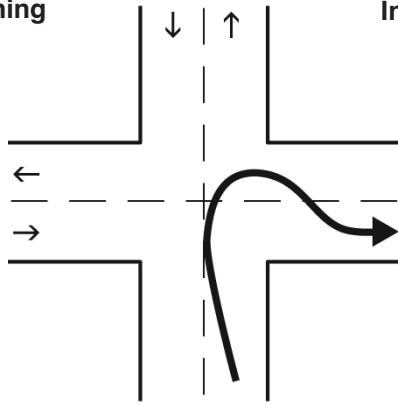

**Figure 2-12**  
Incorrect turning

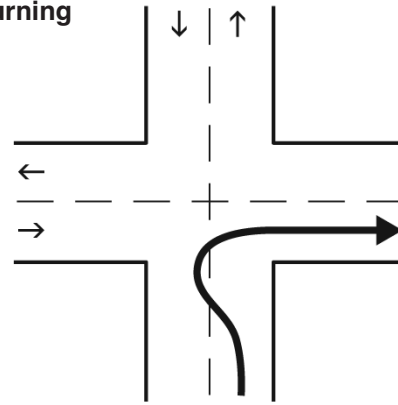

**Figure 2-13**  
If there are two left-turn lanes,  
use the right-hand lane.

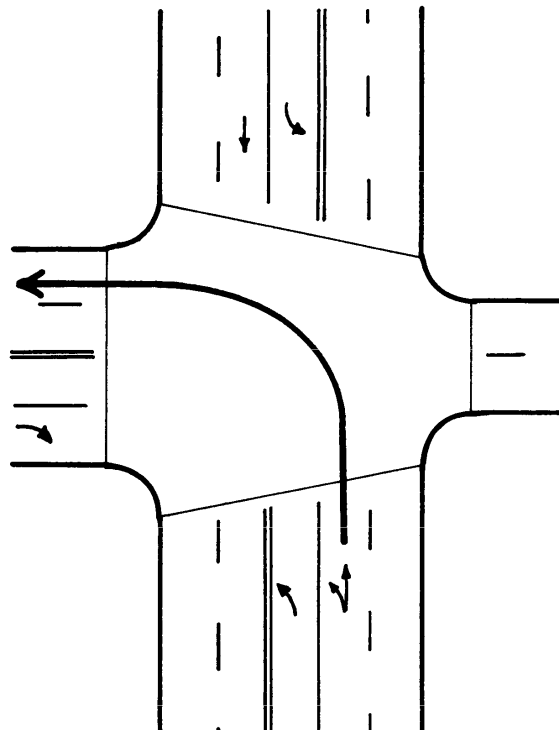

**Space Needed to Cross or Enter Traffic** — Be aware of the size and weight of your vehicle when you cross or enter traffic. Here are some important things to keep in mind:

- Because of slow acceleration and the space large vehicles require, you may need a much larger gap to enter traffic than you would in a car.
- Acceleration varies with the load. Allow more room if your vehicle is heavily loaded.
- Before you start across a road, make sure you can get all the way across before traffic reaches you.

### Test Your Knowledge

1. How do you find out how many seconds of following distance space you have?
2. If you are driving a 30-foot vehicle at 55 mph, how many seconds of following distance should you allow?
3. You should decrease your following distance if somebody is following too closely. True or False?
4. If you swing wide to the left before turning right, another driver may try to pass you on the right. True or False?

**These questions may be on the written exam.  
If you cannot answer all of them, study Section 2.7.**

## 2.8 Driving at Night

You are at greater risk when you drive at night. Drivers cannot see hazards as soon as in daylight, so they have less time to respond. Drivers caught by surprise are less able to avoid a crash. The problems of night driving involve a combination of driver, roadway and vehicle factors.

### Driver Factors —

**Vision:** People cannot see as sharply at night or in dim light. Also, their eyes need time to adjust to seeing in dim light. Most people have noticed this when walking into a dark movie theater.

**Glare:** Drivers can be blinded for a short time by bright light. It takes time to recover from this blindness. Older drivers are especially bothered by glare. Most people have been temporarily blinded by camera flash units or by the high beams of an oncoming vehicle. It can take several seconds to recover from glare. Even 2 seconds of glare blindness can be dangerous. A vehicle going 55 mph will travel more than half the distance of a football field during that time. Do not look directly at bright lights when driving. Look at the right side of the road. Watch the sidelines when someone coming toward you has very bright lights.

**Fatigue and lack of alertness:** Fatigue (being tired) and lack of alertness are bigger problems at night. The body's need for sleep is beyond a person's control. Most people are less alert at night, especially after midnight. This is particularly true if you have been driving for a long time. Drivers may not see hazards as soon or react as quickly, so the chance of a crash is greater. If you are sleepy, the only safe cure is to get off the road and get some sleep. If you do not, you risk your life and the lives of others.

### Roadway Factors —

**Lighting:** In the daytime there is usually enough light to see well. This is not true at night. Some areas may have bright street lights, but many areas will have poor lighting. On most roads you will probably have to depend entirely on your headlights.

Less light means you will not be able to see hazards as well as in daytime. Road users who do not have lights are hard to see. There are many accidents at night involving pedestrians, joggers, bicyclists and animals.

Even when there are lights, the road scene can be confusing. Traffic signals and hazards can be hard to see against a background of signs, shop windows and other lights.

Drive slower when lighting is poor or confusing. Drive slowly enough to be sure you can stop in the distance you can see ahead.

**Drunk drivers:** Drunk and/or drugged drivers are a hazard to themselves and to you. Be especially alert around closing times for bars and taverns. Watch for drivers who have trouble staying in their lane or maintaining speed, stop without reason, or show other signs of being under the influence of alcohol or drugs.

### Vehicle Factors —

**Headlights:** At night your headlights will usually be the main source of light for you to see and for others to see you. You cannot see nearly as much with your headlights as you can see in the daytime. With low beams you can see ahead about 250 feet and with high beams about 350–500 feet. You must adjust your speed to keep your stopping distance within your sight distance. This means going slow enough to be able to stop within the range of your headlights. Otherwise, by the time you see a hazard, you will not have time to stop.

Night driving can be more dangerous if you have problems with your headlights. Dirty headlights may give only half the light they should. This cuts down your ability to see and makes it more difficult for others to see you. Make sure your lights are clean and working. Headlights can be out of adjustment. If they do not point in the right direction, they will not give you a good view and can blind other drivers. Have a qualified person make sure they are adjusted properly.

**Turn signals and brake lights:** At night your turn signals and brake lights are even more important for telling other drivers what you intend to do. Make sure you have clean, working turn signals and stop lights.

**Other lights:** For you to be seen easily, the following must be clean and working properly:

- Reflectors
- Marker lights
- Clearance lights
- Taillights
- Identification lights

**Windshields and mirrors:** It is more important at night than in the daytime to have a clean windshield and clean mirrors. Bright lights at night can cause dirt on your windshield or mirrors to create a glare of its own, blocking your view. Most people have experienced driving toward the sun just as it has risen or is about to set and found that they can barely see through a windshield that seemed to look OK in the middle of the day. Clean your windshield on the inside and outside for safe driving at night.

### Night Driving Tips —

**Pre-trip procedures:** Make sure you are rested and alert. If you are drowsy, sleep before you drive. Even a nap can save your life or the lives of others. If you wear eye glasses, make sure they are clean and unscratched. Do not wear sun glasses at night. Do a complete pre-trip inspection of your vehicle. Pay attention to all lights and reflectors and clean those you can reach.

**Avoid blinding others:** Glare from your headlights can cause problems for drivers coming toward you. Headlights also can bother drivers going in the same direction as you, when your lights shine in their rearview mirrors. Dim your lights before they cause glare for other drivers. Dim your lights within 500 feet of an oncoming vehicle and when following another vehicle within 500 feet.

**Avoid glare from oncoming vehicles:** Do not look directly at the lights of oncoming vehicles. Look slightly to the right at a right lane or edge marking, if available. If other drivers do not put their low-beams on, do not try to “get back at them” by putting your own high-beams on. This increases glare for oncoming drivers and increases the chance of a crash.

**Use high-beams:** Some drivers make the mistake of always using low-beams. This seriously cuts down on their ability to see ahead. Use high-beams when it is safe and legal to do so. Use them when you are not within 500 feet of an approaching vehicle. Also, do not let the inside of your cab get too bright. This makes it harder to see outside. Keep the interior light off, and adjust your instrument lights as low as you can and still read the gauges.

**If you get sleepy, stop driving:** Drivers often do not realize how close they are to falling asleep even when their eyelids are falling shut. If you can safely do so, look at yourself in a mirror. If you look sleepy, or you just feel sleepy, stop driving! You are in a very dangerous condition. The only safe cure is to sleep.

## 2.9 Driving in Fog

Do not drive in fog if at all possible. Pull off the road into a rest area or truck stop until visibility is better. If you must drive:

- Obey all fog-related warning signs.
- Slow before you enter fog.
- Turn on all your lights. (Headlights should be on low-beams.)
- Be prepared for emergency stops.

## 2.10 Driving in Winter

Make sure your vehicle is ready before driving in winter weather by making regular pre-trip inspections.

**Coolant and antifreeze:** Make sure the cooling system is full and there is enough antifreeze in the system to protect against freezing. This can be checked with a special coolant tester.

**Defrosting and heating equipment:** Make sure the defrosters work. Make sure the heater is working and that you know how to operate it. If you use other heaters and expect to need them (e.g., mirror heaters, battery box heaters, fuel tank heaters), check their operation.

**Wipers and washers:** Make sure the windshield wiper blades are in good condition. Make sure the wiper blades press against the window hard enough to wipe the windshield clean. Otherwise they may not sweep off snow properly. Make sure the windshield washer works and there is washing fluid in the washer reservoir.

Use windshield washer antifreeze to prevent freezing of the washer liquid. If you cannot see well enough while driving (e.g., if your wipers fail), stop safely and fix the problem.

**Tires:** Make sure you have enough tread on your tires. The drive tires must provide traction to push the rig over wet pavement and through snow. The steering tires must have traction to steer the vehicle. Enough tread is especially important in winter conditions. You must have at least 4/32-inch tread depth in every major groove on front tires and at least 2/32-inch on other tires. More is better. Use a gauge to determine if you have enough tread for safe driving.

**Tire chains:** You may find yourself in conditions where you cannot drive without chains, even to get to a place of safety. Carry the right number of chains and extra cross links. Make sure they fit your drive tires. Check the chains for broken hooks, worn or broken cross links, and bent or broken side chains. Learn how to put the chains on before you need to do it in snow and ice.

**Lights and reflectors:** Make sure the lights and reflectors are clean. Lights and reflectors are especially important during bad weather. Check from time to time during bad weather to make sure they are clean and working correctly.

**Windows and mirrors:** Remove any ice, snow, etc., from the windshield, windows and mirrors before starting. Use a windshield scraper, snow brush and windshield defroster as necessary.

**Hand holds, steps and deck plates:** Remove all ice and snow from hand holds, steps and deck plates that you must use to enter the cab or to move about the vehicle. This will reduce the danger of slipping.

**Radiator shutters and winterfront:** Remove ice from the radiator shutters. Make sure the winterfront is not closed too tightly. If the shutters freeze shut or the winterfront is closed too much, the engine may overheat and stop.

**Exhaust system:** Exhaust system leaks are especially dangerous when cab ventilation may be poor (windows rolled up, etc.). Loose connections could permit poisonous carbon monoxide to leak into your vehicle. Carbon monoxide gas will cause you to be sleepy. In large enough amounts it can kill you. Check the exhaust system for loose parts and for sounds and signs of leaks.

### Driving Precautions —

**Slippery Surfaces:** Drive slowly and smoothly on slippery roads. If it is very slippery, you should not drive at all. Stop at the first safe place. Following are safety guidelines:

- **Start gently and slowly** – When first starting, get the feel of the road. Do not hurry.
- **Adjust turning and braking to conditions** – Make turns as gentle as possible. Do not brake any harder than necessary, and do not use the engine brake or speed retarder. (They can cause the driving wheels to skid on slippery surfaces.)
- **Adjust speed to conditions** – Do not pass slower vehicles unless necessary. Go slow and watch far enough ahead to keep a steady speed. Avoid having to slow down and speed up. Take curves at slower speeds and do not brake

while in a curve. Be aware that as the temperature rises to the point where ice begins to melt, the road becomes even more slippery. Slow down more.

- **Adjust space to conditions** – Do not drive alongside other vehicles. Keep a longer following distance. When you see a traffic jam ahead, slow down or stop to wait for it to clear. Try hard to anticipate stops early and slow down gradually.

**Wet brakes:** When driving in heavy rain or deep standing water, your brakes will get wet. Water in the brakes can cause the brakes to be weak, to apply unevenly or to grab. This can cause lack of braking power, wheel lock-ups, pulling to one side or the other, and jackknife if you pull a trailer.

Avoid driving through deep puddles or flowing water if possible. If you cannot avoid them:

- Slow down.
- Place transmission in a low gear.
- Gently put on the brakes. This presses linings against brake drums or discs and keeps mud, silt, sand and water from getting in.
- Increase engine RPM and cross the water while keeping light pressure on the brakes.
- When out of the water, maintain light pressure on the brakes for a short distance to heat them up and dry them out.
- Make a test stop when safe to do so. Check behind to make sure no one is following, then apply the brakes to be sure they work right. If not, dry out further as described above. (CAUTION: Do not apply too much brake pressure and accelerator at the same time or you can overheat brake drums and linings.)

## 2.11 Driving in Very Hot Weather

Make sure your vehicle is ready before driving in very hot weather by making regular pre-trip inspections.

**Tires:** Check the tire mounting and air pressure. Inspect the tires every two hours or every 100 miles when driving in very hot weather. Air pressure increases with temperature. Do not let air out or the pressure will be too low when the tires cool off. If a tire is too hot to touch, remain stopped until the tire cools off. Otherwise the tire may blow out or catch fire. A burning tire should be cooled with water.

**Engine oil:** The engine oil helps keep the engine cool, as well as lubricates it. Make sure there is enough engine oil. If you have an oil temperature gauge, make sure the temperature is within the proper range while you are driving.

**Engine coolant:** Before starting out, make sure the engine cooling system has enough water and antifreeze according to the engine manufacturer's directions. (Antifreeze helps the engine under hot conditions as well as cold conditions.) When driving, check the water temperature or coolant temperature gauge from time to time. Make sure it remains in the normal range. If the gauge goes above the highest safe temperature, there may be something wrong that could lead to engine failure and possibly fire. Stop driving as soon as safely possible and try to find out what is wrong.

Some vehicles have sight glasses, see-through coolant overflow containers or coolant recovery containers. These permit you to check the coolant level while the engine is hot. If the container is not part of the pressurized system, the cap can be safely removed and coolant added even when the engine is at operating temperature.

**Never remove the radiator cap or any part of the pressurized system until the system has cooled.** Steam and boiling water can spray under pressure and cause severe burns. If you can touch the radiator cap with your bare hand, it is probably cool enough to open.

If coolant must be added to a system without a recovery tank or overflow tank:

- Shut engine off.
- Wait until engine has cooled.
- Protect hands (use gloves or a thick cloth).
- Turn radiator cap slowly to the first stop, which releases the pressure seal.
- Step back while pressure is released from cooling system.
- When all pressure has been released, press down on the cap and turn it further to remove it.
- Visually check level of coolant and add more coolant if necessary.
- Replace cap and turn all the way to the closed position.

**Engine belts:** Learn how to check V-belt tightness on your vehicle by pressing on the belts. Loose belts will not turn the water pump and/or fan properly. This will result in overheating. Also check belts for cracking or other signs of wear.

**Hoses:** Make sure coolant hoses are in good condition. A broken hose while driving can lead to engine failure and even fire.

## Driving Precautions —

**Watch for bleeding tar:** Tar in the road pavement frequently rises to the surface in very hot weather. Spots where tar “bleeds” to the surface are very slippery.

**Go slow enough to prevent overheating:** High speeds create more heat for tires and the engine. In desert conditions the heat may build up to the point where it is dangerous. The heat will increase chances of tire failure or even fire and engine failure.

### Test Your Knowledge

1. You should use low-beams whenever you can. True or False?
2. What should you do before you drive if you are drowsy?
3. What effects can wet brakes cause? How can you avoid these problems?
4. You should let air out of hot tires so the pressure goes back to normal. True or False?
5. You can safely remove the radiator cap as long as the engine is not overheated. True or False?

**These questions may be on the written exam.**

**If you cannot answer all of them, study Sections 2.8 through 2.11.**

## 2.12 Railroad Crossings

Railroad crossings are always dangerous. Every crossing must be approached with the expectation that a train is coming. Follow these safety precautions:

- Do not rely solely upon the presence of warning signals, gates, or flagmen to warn of approaching trains.
- Never attempt to race a train to a crossing. It is extremely difficult to judge the speed of an approaching train.
- Reduce speed in accordance with your ability to see approaching trains in any direction, and maintain a speed that will allow you to stop short of the tracks if a stop is necessary.
- Because of noise in the cab, you cannot expect to hear the train horn until the train is dangerously close to the crossing.
- Double tracks require a double check. A train on one track may hide a train on the other track. Look both ways before crossing. After one train has cleared a crossing, be sure no other trains are near before starting across the tracks.
- Yard areas and grade crossings in cities and towns are just as dangerous as rural grade crossings. Approach them with as much caution.
- A complete stop is required at a grade crossing when:
  - The nature of the cargo makes a stop mandatory under state or federal regulations.
  - Such a stop is otherwise required by law.
- Railroad crossings with steep approaches can cause your unit to hang up on the tracks.
- Never permit traffic conditions to trap you in a position where you have to stop on the tracks. Be sure you can get all the way across the tracks before you start across.
- **DO NOT shift gears while crossing railroad tracks.**

## 2.13 Mountain Driving

Gravity plays a major role in mountain driving. On any upgrade, gravity slows you down. The steeper the grade, the longer the grade, and/or the heavier the load, the more you will have to use lower gears to climb hills or mountains.

In coming down long, steep downgrades, gravity causes the speed of your vehicle to increase. You must select an appropriate safe speed, then use a low gear, and use proper braking techniques. Plan ahead and obtain information about any long steep grades along your planned route of travel. If possible, talk to other drivers who are familiar with the grades to find out what speeds are safe.



You must go slow enough so your brakes can hold you back without getting too hot. If the brakes become too hot, they may start to “fade.” This means you have to apply them harder and harder to get the same stopping power. If you continue to use the brakes hard, they can keep fading until you cannot slow down or stop at all.

**Speed** — Your most important consideration is to select a speed that is not too fast for the:

- total weight of the vehicle and cargo,
- length of the grade,
- steepness of the grade,
- road conditions, and/or the
- weather.

If a speed limit is posted or there is a sign indicating “Maximum Safe Speed,” never exceed the speed shown. Also, look for and heed warning signs indicating the length and steepness of the grade.

You must use the braking effect of the engine as the principal way of controlling your speed. The braking effect of the engine is greatest when it is near the governed RPMs and the transmission is in the lower gears. Save your brakes so you will be able to slow or stop as required by road traffic conditions.

**Be in Right Gear Before Starting Down Grade** — Shift the transmission to a low gear before starting down the grade. Do not try to downshift after your speed has already built up. You will not be able to shift into a lower gear. You may not even be able to get back into any gear and all engine braking effect will be lost. Forcing an automatic transmission into a lower gear at high speed could damage the transmission and also lead to loss of all engine braking effect.

A good rule for older trucks is to use the same gear going down a hill that you would need to climb the hill. However, newer trucks have low-friction parts and streamlined shapes for fuel economy. They also may have more powerful engines. This means they can go up hills in higher gears and have less friction and air drag to hold them back going down hills. For that reason, drivers of modern trucks may have to use lower gears going down a hill than would be required to go up the hill. Know what is right for your vehicle.

**Brake Fading or Failure** — Brakes are designed so brake shoes or pads rub against the brake drum or disks to slow the vehicle. Braking creates heat. But brakes are designed to take a lot of heat. However, brakes can fade or fail from excessive heat caused by using them too much and not relying on the engine braking effect.

Brake fade also is affected by adjustment. To safely control a vehicle, each brake must do its share of the work. Brakes out of adjustment will stop doing their shares before those that are in adjustment. The other brakes can then overheat and fade, and there will not be enough braking available to control the vehicle. Brakes can get out of adjustment quickly, especially when they are used a lot; brake linings also wear faster when they are hot. Therefore, brake adjustment must be checked frequently.

**Proper Braking Technique** — The use of brakes on a long and/or steep downgrade is only a supplement to the braking effect of the engine. Once the vehicle is in the proper low gear, the following is a proper braking technique:

1. Apply the brakes just hard enough to feel a definite slowdown.
2. When your speed has been reduced to approximately 5 mph below your “safe” speed, release the brakes. (This brake application should last for about 3 seconds.)
3. When your speed has increased to your “safe” speed, repeat steps 1 and 2.

**Example:** If your “safe” speed is 40 mph, you would not apply the brakes until your speed reaches 40 mph. You now apply the brakes hard enough to gradually reduce your speed to 35 mph and then release the brakes. Repeat this as often as necessary until you have reached the end of the downgrade.

**Escape Ramps** — Escape ramps have been built on many steep mountain downgrades. Escape ramps are made to stop runaway vehicles safely without injuring drivers and passengers. Escape ramps use a long bed of loose soft material to slow a runaway vehicle, sometimes in combination with an upgrade.

Know escape ramp locations on your route. Signs show drivers where ramps are located. Escape ramps save lives, equipment and cargo. Use them if you lose your brakes.

## 2.14 Seeing Hazards

A hazard is any road condition or other road user (driver, bicyclist, pedestrian) that is a possible danger. For example, a car in front of you is headed toward the freeway exit, but the car's brake lights come on and the driver begins braking hard. This could mean that the driver is uncertain about taking the offramp. He/she might suddenly return to the highway. This car is a hazard. If the driver of the car cuts in front of you, it is no longer just a hazard; it is an emergency.

**Seeing Hazards Lets You Be Prepared** — You will have more time to act if you see hazards before they become emergencies. In the example above, you might make a lane change or slow down to prevent an accident if the car suddenly cuts in front of you. Seeing this hazard gives you time to check your mirrors and signal a lane change. Being prepared reduces the danger. A driver who did not see the hazard until the slow car pulled back on the highway in front of him/her would have to do something very suddenly. Sudden braking or a quick lane change is much more likely to lead to an accident.

There are often clues that will help you see hazards. The more you drive, the better you get at spotting hazards. Slow down and be very careful if you see any of the following road hazards:

**Work zones:** When people are working on the road it is a hazard. There may be narrower lanes, sharp turns or uneven surfaces. Other drivers are often distracted and drive unsafely. Workers and construction vehicles may get in the way. Drive slowly and carefully near work zones. Use your four-way flashers or brake lights to warn drivers behind you.

**Drop-offs:** Sometimes the pavement drops off sharply near the edge of the road. Driving too close to the edge can tilt your vehicle toward the side of the road. This can cause the top of your vehicle to hit roadside objects (signs, tree limbs, etc.). It also can be hard to steer as you cross the drop-off, whether going off the road or coming back on.

**Foreign objects:** Things that have fallen on the road can be hazards. They can be a danger to your tires and wheel rims, damage electrical and brake lines, or become caught between dual tires and cause severe damage. Some obstacles that can appear to be harmless can be very dangerous. For example, cardboard boxes may be empty, but they also may contain solid or heavy material capable of causing damage. The same is true of paper and cloth sacks. Remain alert for objects of all sorts, so you avoid them without making sudden, unsafe moves.

**Offramps/onramps:** Freeway and turnpike exits can be particularly dangerous for commercial vehicles. Offramps and onramps often have speed limit signs posted. Remember, these speeds may be safe for automobiles **but may not be safe for larger vehicles or heavily loaded vehicles**. Exits that go downhill and turn at the same time can be especially dangerous. The downgrade makes it difficult to reduce speed. Braking and turning at the same time can be a dangerous practice. Make sure you are going slow enough before you get on the curved part of an offramp or onramp.

**Hazardous Drivers, Vehicles and Pedestrians** — To protect yourself and others, you must know when other drivers may do something hazardous. Some clues to these types of hazards include:

- **People who cannot see others** — Be alert for drivers whose vision is blocked. Vans, loaded station wagons and cars with the rear window blocked are examples.
- **Rental trucks** — Drivers often are not used to the limited vision they have to the sides and rear of the truck.
- **Vehicles with frosted, ice-covered or snow-covered windows.**
- **Partially hidden vehicles** — Vehicles may be partly hidden by blind intersections or alleys. If you can see only the rear or front end of a vehicle but not the driver, then he/she cannot see you. Be alert because he/she may back out or enter into your lane. Always be prepared to stop.
- **Delivery trucks** — The driver's vision often is blocked by packages or vehicle doors. Drivers of step vans, postal vehicles and local delivery vehicles often are in a hurry and may suddenly step out of their vehicle or drive into the traffic lane.
- **Parked vehicles** — Parked vehicles can become hazards when passengers start to get out. Or they may suddenly start up and drive into your path. Watch for movement inside the vehicle or movement of the vehicle itself that shows people are inside. Watch for brake lights or backup lights, exhaust and other clues that a driver is about to move.
- **Stopped buses** — Passengers may cross in front of or behind the bus, and they often cannot see you.
- **Pedestrians and bicyclists** — Walkers, joggers and bicyclists may be on the road with their backs to the traffic, so they cannot see you. They also may be wearing electronic devices so they cannot hear you either. On rainy days, pedestrians may not see you because of hats or umbrellas. They may be hurrying to get out of the rain and may not pay attention to the traffic.
- **People who are distracted** — Watch for where they are looking. If they are looking elsewhere, they cannot see you. But be alert even when they are looking at you; they may think they have the right-of-way.

- **Children** – Children tend to act quickly without checking traffic. Children playing with one another may not look for traffic and are a serious hazard.
- **Talkers** – Drivers or pedestrians talking to one another may not be paying close attention to the traffic.
- **Workers** – People working on or near the roadway creates a distraction for other drivers, and the workers themselves may not see you.
- **Ice cream trucks** – Children may be nearby and may not see you.
- **Disabled vehicles** – Drivers changing a tire or fixing an engine often do not pay attention to the dangers of roadway traffic. They often are careless. Jacked-up wheels or raised hoods are hazard clues.
- **Accidents** – People involved in the accident may not look for traffic. Passing drivers tend to look at the accident. People often run across the road without looking. Vehicles may slow down or stop suddenly.
- **Shoppers** – People in and around shopping areas often are not watching traffic because they are looking for stores or looking into store windows.
- **Turning vehicles** – Drivers signaling a turn may be a hazard. Drivers signaling a turn may slow more than expected or stop. If they are making a tight turn into an alley or driveway, they may go very slow. If they are blocked by pedestrians or other vehicles, they may have to stop on the roadway. Vehicles turning left may have to stop for oncoming vehicles.
- **Confused drivers** – Confused drivers often change direction suddenly or stop without warning. Confusion is common near freeway or turnpike interchanges and major intersections. Tourists unfamiliar with the area can be very hazardous. Clues to tourists include car-top luggage and out-of-state license plates. Unexpected actions (stopping in the middle of a block, changing lanes for no apparent reason, back-up lights suddenly going on) are clues to confusion. Hesitation is another clue, including driving very slowly, using brakes often or stopping in the middle of an intersection. You also may see drivers looking at street signs, maps and house numbers. These drivers may not be paying attention to you.
- **Slow drivers** – Motorists who fail to maintain normal speed are hazards. Seeing slow-moving vehicles early can prevent a crash. Some vehicles, by their nature, are slow and seeing them is a hazard clue (mopeds, farm implements, construction machinery, tractors, etc.). Some will have the Slow-Moving Vehicle symbol to warn you. Watch for a red triangle with an orange center.
- **Drivers in a hurry** – Drivers may feel your commercial vehicle is preventing them from getting where they want to go on time. Such drivers may pass you without a safe gap in the oncoming traffic, cutting too close in front of you. Drivers entering the road may pull in front of you to avoid being stuck behind you, causing you to brake. Be aware of this and watch for drivers who are in a hurry.
- **Impaired drivers** – Drivers who are sleepy, have had too much to drink, are on drugs, or are ill are hazards. Some clues to these drivers include:
  - Weaving across the road or drifting from one side to another.
  - Leaving the road (dropping right wheels onto the shoulder, or bumping across a curb in a turn).
  - Stopping at the wrong time (stopping at a green light, or waiting too long at a stop).
  - Open window in cold weather.
  - Speeding up or slowing down suddenly, driving too fast or too slow.

Be alert for drunk drivers and sleepy drivers late at night.

**Driver Body Movement as a Clue** – Drivers look in the direction they are going to turn. You may sometimes get a clue from a driver's head and body movements that a driver may be going to make a turn even though the turn signals are not on. Drivers making over-the-shoulder checks may be going to change lanes. These clues are most easily seen in motorcyclists and bicyclists. Watch other road users, and try to tell whether they might do something hazardous.

**Conflicts** – You are in conflict when you have to change speed and/or direction to avoid hitting someone. Conflicts occur at intersections where vehicles meet, at merges (such as turnpike on ramps) and where there are needed lane changes (such as the end of a lane, forcing a move to another lane of traffic). Other situations include slow-moving or stalled traffic in a traffic lane, and accident scenes. Watch for other drivers who are in conflict because they are a hazard to you. When they react to this conflict, they may do something that will put them in conflict with you.

You should always be looking for hazards. Continue to learn to see hazards on the road. However, do not forget why you are looking for the hazards – they may turn into emergencies. You look for hazards in order to have time to plan a way out of any emergency. When you see a hazard, think about the emergencies that could develop and figure out what you would do. Always be prepared to take action based on your plans. This way, you will be a prepared, defensive driver who will improve not only your own safety but the safety of everyone on the road.

## Test Your Knowledge

1. What factors determine your selection of a “safe” speed when going down a long, steep downgrade?
2. Why should you be in the proper gear **before** starting down a hill?
3. Describe the proper braking technique when going down a long, steep downgrade.
4. What is a hazard?
5. Why make emergency plans when you see a hazard?

**These questions may be on the written exam.  
If you cannot answer all of them, study Sections 2.12 through 2.14.**

## 2.15 Emergencies

**Traffic emergencies** occur when two vehicles are about to collide. **Vehicle emergencies** occur when tires, brakes or other critical parts fail. Following the safety practices in this manual can help prevent emergencies. But if an emergency does happen, your chances of avoiding an accident depend upon how well you take action.

**Steering to Avoid a Crash** — Stopping is not always the safest thing to do in an emergency. When you do not have enough room to stop, you may have to steer away from what is ahead. Remember, you can almost always turn to miss an obstacle more quickly than you can stop. (However, top-heavy vehicles and tractors with multiple trailers may overturn.)

**Turning quickly:** To turn quickly, you must have a firm grip on the steering wheel with both hands. A quick turn can be made safely if it is done correctly.

- **Do not** apply the brakes while you are turning. It is very easy to lock your wheels while turning. If that happens, you may skid out of control.
- **Do not** turn any more than needed to clear whatever is in your way. The more sharply you turn, the greater the chances of a skid or rollover.
- Be prepared to “countersteer,” that is, to turn the wheel back in the other direction once you have passed whatever was in your path. Unless you are prepared to countersteer, you will not be able to do it quickly enough. Think of emergency steering and countersteering as two parts of one driving action.

**Where to steer:** If an oncoming driver has drifted into your lane, a move to your right is best. If that driver realizes what has happened, the natural response will be to return to his/her own lane. If something is blocking your path, the best direction to steer will depend on the situation.

- If you have been using your mirrors, you will know which lane is empty and can be safely used.
- If the shoulder is clear, going right may be best. No one is likely to be driving on the shoulder, but someone may be passing you on the left. You will know if you have been using your mirrors.
- If you are blocked on both sides, a move to the right may be best. At least you will not force anyone into an opposing traffic lane and a possible head-on collision.

**Leaving the road:** In some emergencies, you may have to drive off the road. It may be less risky than facing a collision with another vehicle. Most shoulders are strong enough to support the weight of a large vehicle and, therefore, offer an available escape route. Following are guidelines if you must leave the road:

- **Avoid braking** — If possible, avoid using the brakes until your speed has dropped to about 20 mph. Then brake very gently to avoid skidding on a loose surface.
- **Keep one set of wheels on pavement if possible** — This helps to maintain control of the vehicle.
- **Stay on the shoulder** — If the shoulder is clear, stay on it until your vehicle has come to a complete stop. Signal and check your mirrors before pulling back onto the road.

**Returning to the road:** If you are forced to return to the road before you can stop, use the following procedures:

- Hold the wheel tightly and turn sharply enough to get right back on the road safely. Do not try to edge gradually back on the road. If you do, your tires might grab unexpectedly and you could lose control.

- When both front tires are on the paved surface, **countersteer** immediately. The two turns should be made as a single “steer-countersteer” move.

**Stopping Quickly and Safely** — If somebody suddenly pulls out in front of you, your natural response is to hit the brakes. This is a good response if there is enough distance to stop and you use the brakes correctly. You should brake in a way that will keep your vehicle in a straight line and allow you to turn if it becomes necessary. You can use the “controlled braking” or the “stab braking” methods.

**Controlled braking:** With this method, you apply the brakes as hard as you can **without** locking the wheels. Keep steering wheel movements very small while doing this. If you need to make a larger steering adjustment or if the wheels lock, release the brakes. Reapply the brakes as soon as you can.

**Stab braking:** Use only on vehicles without anti-lock brake systems.

- Apply your brakes all the way.
- Release brakes when wheels lock up.
- As soon as the wheels start rolling, apply the brakes fully again. (It can take up to 1 second for the wheels to start rolling after you release the brakes. If you reapply the brakes before the wheels start rolling, the vehicle will not straighten out.)

**Do not jam on the brakes:** Use only on vehicles without anti-lock brake systems. Emergency braking does not mean pushing down on the brake pedal as hard as you can. That will only keep the wheels locked up and cause a skid. If the wheels are skidding, you cannot control the vehicle.

**Note: If you drive a vehicle with anti-lock brakes, read and follow the directions for stopping quickly in the owner’s manual.**

**Brake Failure** — Brakes kept in good condition rarely fail. Most hydraulic brake failures occur for one of two reasons: loss of hydraulic pressure or brake fade on long hills. (Air brakes are discussed in Section 5.)

**Loss of hydraulic pressure:** When the system will not build up pressure, the brake pedal will feel spongy or go to the floor. Following are things you can do:

- **Downshift** – Putting the vehicle into a lower gear will help to slow the vehicle.
- **Pump the brakes** – Sometimes pumping the brake pedal will generate enough hydraulic pressure to stop the vehicle.
- **Use the parking brake** – The parking or emergency brake is separate from the hydraulic brake system. Therefore, it can be used to slow the vehicle. However, be sure to press the release button or pull the release lever at the same time you use the emergency brake so you can adjust the brake pressure and keep the wheels from locking up.

**Find an escape route:** While slowing the vehicle, look for an escape route — an open field, side street or escape ramp. Turning uphill is a good way to slow and stop the vehicle. Make sure the vehicle does not start rolling backward after you stop. Put it in low gear, apply the parking brake and, if necessary, roll back into some obstacle that will stop the vehicle.

**Brake failure on downgrades:** Going slow enough and braking properly will almost always prevent brake failure on long downgrades. Once the brakes have failed, however, look outside your vehicle for something to stop it.

Your best hope is an **escape ramp**. If there is one, there will be signs posted. Ramps are usually located a few miles from the top of the downgrade. Every year, hundreds of drivers avoid injury to themselves or damage to their vehicles by using escape ramps. Some escape ramps use soft gravel that resists the motion of the vehicle and brings it to a stop. Others turn uphill, using the hill to stop the vehicle and soft gravel to hold it in place.

Any driver who loses brakes going downhill should use an escape ramp if available. If you do not use it, your chances of having a serious accident may be much greater.

If no escape ramp is available, take the least hazardous escape route you can, such as an open field or a side road that flattens out or turns uphill. Make the move as soon as you know your brakes do not work. The longer you wait, the faster the vehicle will go and the harder it will be to stop.

**Tire Failure** — Quickly knowing you have a tire failure will let you have more time to react. Having just a few seconds to remember what it is you are supposed to do can help you. The major signs of tire failure are:

- **Sound** – The loud “bang” of a blowout is an easily recognized sign. Because it can take a few seconds for your vehicle to react, you might think it was another vehicle. But any time you hear a tire blow, you are safest to assume it is yours.

- **Vibration** – If the vehicle thumps or vibrates heavily, it may be a sign that one of the tires has gone flat. With a rear tire, that may be the only sign you get.
- **Feel** – If the steering feels “heavy,” it is probably a sign that one of the front tires has failed. Sometimes, failure of a rear tire will cause the vehicle to slide back and forth or “fishtail.” However, dual rear tires usually prevent this.

Any of the above signs is a warning of possible tire failure, and you should do the following:

- **Hold the steering wheel firmly** – If a front tire fails, it can twist the steering wheel out of your hand. The only way to prevent this is to keep a firm grip on the steering wheel with both hands at all times.
- **Stay off the brake** – It is natural to want to brake in an emergency. However, braking when a tire has failed could cause loss of control. Unless you are about to run into something, stay off the brake until the vehicle has slowed down. Then brake very gently, pull off the road and stop.
- **Check the tires** – After you have come to a stop, get out and check all the tires. Do this even if the vehicle seems to be handling all right. If one of your dual tires goes, the only way you may know it is by getting out and looking at the tires.

## 2.16 Skid Control and Recovery

A skid happens whenever the tires lose their grip on the road. This is caused by one of four ways:

1. **Over-braking** – Braking too hard and locking up the wheels. Skids also can occur when using the speed retarder when the road is slippery.
2. **Over-steering** – Turning the wheels more sharply than the vehicle can turn.
3. **Over-acceleration** – Supplying too much power to the drive wheels, causing them to spin.
4. **Driving too fast** – Most serious skids result from driving too fast for road conditions. Drivers who adjust their driving to conditions do not over-accelerate and do not have to over-brake or over-steer from too much speed.

By far the most common skid is one in which the rear wheels lose traction through excessive braking or acceleration. Skids caused by acceleration usually happen on ice or snow. They can easily be stopped by taking your foot off the accelerator. (If it is very slippery, push the clutch in. Otherwise, the engine can keep the wheels from rolling freely and regaining traction.)

**Drive-Wheel Skids** — Rear-wheel braking skids occur when the rear-drive wheels lock. Because locked wheels have less traction than rolling wheels, the rear wheels usually slide sideways in an attempt to “catch up” with the front wheels. In a bus or straight truck, the vehicle will slide sideways in a “spin out.” With vehicles towing trailers, a drive-wheel skid can let the trailer push the towing vehicle sideways, causing a sudden jackknife (see Figure 2-14 on page 45).

Do the following to correct a drive-wheel braking skid:

- **Stop braking** – This will let the rear wheels roll again and keep the rear wheels from sliding any further. If on ice, push in the clutch to let the wheels turn freely.
- **Turn quickly** – When a vehicle begins to slide sideways, quickly steer in the direction you want the vehicle to go—down the road. You must turn the wheel quickly.
- **Countersteer** – As a vehicle turns back on course, it has a tendency to keep right on turning. Unless you turn the steering wheel quickly the other way, you may find yourself skidding in the opposite direction.

Learning to stay off the brake, turn the steering wheel quickly, push in the clutch and countersteer in a skid takes a lot of practice. The best place to get this practice is on a large driving range or “skid pad.”

**Front-Wheel Skids** — Most front-wheel skids are caused by driving too fast for conditions. Other causes are lack of tread on the front tires, and cargo loaded so not enough weight is on the front axle. In a front-wheel skid, the front end tends to go in a straight line regardless of how much you turn the steering wheel. On a very slippery surface, you may not be able to steer around a curve or turn.

When a front-wheel skid occurs, the only way to stop the skid is to let the vehicle slow down. Stop turning and/or braking so hard. Slow down as quickly as possible without skidding.

**Figure 2-14**  
**Tractor Jackknife**

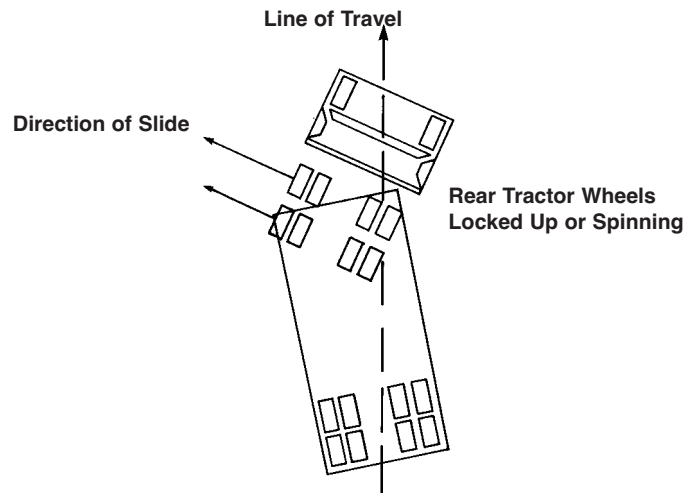

**Test Your Knowledge**

1. Stopping is not always the safest thing to do in an emergency. True or False?
2. What are some advantages of going right instead of left around an obstacle?
3. What is an escape ramp?
4. If a tire blows out, you should put the brakes on hard to stop quickly. True or False?

**These questions may be on the written exam.**  
**If you cannot answer all of them, study Sections 2.15 and 2.16.**

**2.17 Accident Procedures**

When you are in an accident and not seriously hurt, you need to act to prevent further damage or injury. The basic steps to be taken at any accident are:

1. Protect the area.
2. Notify authorities.
3. Assist the injured.

**Protect the Area** — The first thing to do at an accident scene is to keep another accident from happening at the same spot.

- If your vehicle is involved in the accident, try to get it to the side of the road. This will help prevent another accident and allow traffic to move.
- If you are stopping to help, park away from the accident. The area immediately around the accident will be needed for emergency vehicles.
- Put on your flashers.
- Set out reflective triangles to warn other traffic. Make sure they can be seen by other drivers in time for them to avoid the accident.

**Notify Authorities** — If you have a CB, put out a call over the emergency channel before you get out of your vehicle. If not, wait until after the accident scene has been properly protected, then phone or send someone to phone the police. Try to determine where you are so you can give the exact location.

**Assist the Injured** — If a qualified person is at the accident and helping the injured, stay out of the way unless asked to assist. Otherwise, do the best you can to help any injured parties:

- Do not move a severely injured person unless the danger of fire or passing traffic makes it necessary.
- Stop heavy bleeding by applying direct pressure to the wound.
- Keep the injured person warm.

## 2.18 Fires

Truck fires can cause damage and injury. Learn the causes of fires and how to prevent them. Know what to do to extinguish fires. Following are some causes of vehicle fires:

- **After accidents** – Spilled fuel, improper use of flares.
- **Tires** – Underinflated tires and duals that touch.
- **Electrical system** – Short circuits due to damaged insulation, loose connections.
- **Fuel** – Driver smoking, improper fueling, loose fuel connections.
- **Cargo** – Flammable cargo, improperly sealed or loaded, poor ventilation.

**Fire Prevention** — Pay attention to the following:

**Pre-trip inspection:** Make a complete inspection of the electrical, fuel and exhaust systems, tires and cargo. Be sure to check that the fire extinguisher is charged.

**Enroute inspection:** Check the tires, wheels and truck body for signs of heat whenever you stop during a trip.

**Follow safety procedures:** Follow correct safety procedures for fueling the vehicle, using brakes, handling flares and other activities that can cause a fire.

**Monitoring:** Check the instruments and gauges often for signs of overheating, and use the mirrors to look for signs of smoke from tires or the vehicle.

**Use normal caution in handling anything flammable.**

**Fire Fighting** — Knowing how to fight fires is important. Fires have been made worse by drivers who do not know what to do. Know how the fire extinguisher works. Study the instructions printed on the extinguisher before you need it. Follow these procedures in case of a fire:

**Pull off the road:** The first step is to get the vehicle off the road and stop.

- Park in an open area, away from buildings, trees, brush, other vehicles or anything that might catch fire.
- **Do not pull into a service station.**
- Notify emergency services of your problem and your location.

**Keep the fire from spreading:** Before trying to put out the fire, make sure it does not spread any further.

- With an **engine** fire, turn off the engine as soon as you can. Do not open the hood if you can avoid it. Shoot extinguishers through louvers or radiator or from the underside of the vehicle.
- For a **cargo** fire in a van or box trailer, keep the doors shut, especially if your cargo contains hazardous materials. Opening the van doors will supply the fire with oxygen and can cause it to burn very fast.

**Use the right fire extinguisher:**

- The B:C type fire extinguisher is designed to work on electrical fires and burning liquids. The A:B:C type is designed to work on burning wood, paper and cloth as well.
- Water can be used on wood, paper or cloth, but do not use water on an electrical fire (you could get shocked) or a gasoline fire (it will just spread the flames).
- A burning tire must be cooled. Lots of water may be required.
- If you are not sure what to use, especially on a hazardous materials fire, wait for qualified firefighters.

**Extinguish the fire:**

- Only try to extinguish a fire if you know what you are doing and it is safe to do so.
- When using the extinguisher, stay as far away from the fire as possible.
- Aim at the source or base of the fire, not up in the flames.
- Position yourself upwind. Let the wind carry the extinguisher to the fire rather than carrying the flames to you.
- Continue until whatever was burning has been cooled. Absence of smoke or flames does not mean the fire is completely out or cannot restart.



## Test Your Knowledge

1. What are some things to do at an accident scene to prevent another accident?
2. Name two causes of tire fires?
3. What kinds of fires are B:C extinguishers **not** good for?
4. When using your extinguisher, should you get as close as possible to the fire?
5. Name some causes of vehicle fires?

**These questions may be on the written exam.  
If you cannot answer all of them, study Sections 2.17 and 2.18.**

## 2.19 Staying Alert and Fit to Drive

Driving a vehicle for long hours is tiring. Even the best of drivers will become less alert. Following are things you can do to help you stay alert and safe.

### Be Ready to Drive —

**Get enough sleep:** Leaving on a long trip when you are already tired is dangerous. If you have a long trip scheduled, make sure you get enough sleep before you go. Most people require 7-8 hours of sleep every 24 hours.

**Schedule trips safely:** Your body gets used to sleeping during certain hours. If you are driving during those hours, you will be less alert. If possible, try to schedule trips for the hours you are normally awake. Many heavy motor vehicle accidents occur between midnight and 6 a.m. Tired drivers can easily fall asleep at these times, especially if they do not regularly drive at those hours. Trying to push on and finish a long trip at these times can be very dangerous.

**Avoid medication:** Many medicines can make you sleepy. Those that do have a label warning against operating vehicles or machinery. The most common medicine of this type is an ordinary cold pill. If you have to drive with a cold, you are better off suffering from the cold than from the effects of the medicine.

**Keep cool:** A hot, poorly ventilated cab can make you sleepy. Keep the window or vent cracked or use the air conditioner if you have one.

**Take breaks:** Short breaks can keep you alert. But the time to take them is before you feel really drowsy or tired. Stop often. Walk around and inspect your vehicle. It may help to do some physical exercises. When you are sleepy, trying to “push on” is far more dangerous than most drivers think. It is a major cause of fatal accidents. Following are some important rules:

**Stop to sleep:** When your body needs sleep, sleep is the only thing that will work. If you have to make a stop anyway, make it whenever you feel the first signs of sleepiness, even if it is earlier than you planned. By getting up a little earlier the next day, you can keep on schedule without the danger of driving while you are not alert.

**Take a nap:** If you cannot stop for the night, at least pull off at a safe place, such as a rest area or truck stop, and take a nap. A nap as short as a half-hour will do more to overcome fatigue than a half-hour coffee stop.

**Avoid drugs:** There are no drugs that can overcome being tired. While they may keep you awake for a while, they will not make you alert. And eventually, you will be even more tired than if you had not taken them at all. Sleep is the only thing that can overcome fatigue.

**Alcohol and Driving —** Drinking alcohol and then driving is a very serious problem. People who drink alcohol are involved in traffic accidents resulting in more than 20,000 deaths annually. You should know:

- How alcohol works in the human body.
- How it affects driving.
- Laws regarding drinking and driving.
- Legal, financial and safety risks of drinking and driving.

**How alcohol works:** Alcohol goes directly from the stomach into the blood stream. A drinker can control the amount of alcohol that he/she takes in by having fewer drinks or none. However, the drinker cannot control how fast the body gets rid of alcohol. If you have drinks faster than the body can get rid of them, you will have more alcohol in your body, and your driving will be more affected. The amount of alcohol in your body is commonly measured by the blood-alcohol concentration (BAC).

**What determines BAC:** BAC is determined by the amount of alcohol you drink (more alcohol means a higher BAC), how fast you drink (faster drinking means a higher BAC) and your weight (a small person does not have to drink as much to reach the same BAC).

**What constitutes a “drink”:** A “drink” refers to the alcohol in a drink that affects human performance. It does not make any difference whether the alcohol comes from a couple of beers or two glasses of wine or two shots of hard liquor. All the following drinks **contain the same amount of alcohol:**

- 12-oz. glass of 5% beer
- 5-oz. glass of 12% wine
- 1 1/2-oz. shot of 80-proof liquor

**Alcohol and the brain:** Alcohol affects more and more of the brain as BAC builds up. The first part of the brain affected controls judgment and self control. One of the bad things about this is it can keep drinkers from knowing they are getting drunk. As BAC continues to build up, muscle control, vision and coordination are affected more and more. Eventually, a person will pass out.

**How alcohol affects driving:** All drivers are affected by drinking alcohol. Alcohol affects judgment, vision, coordination and reaction time. It causes serious driving errors, such as:

- Increased reaction time to hazards.
- Driving too fast or too slow.
- Driving in the wrong lane.
- Running over the curb.
- Weaving.
- Straddling lanes.
- Quick, jerky starts.
- Not signaling, failure to use lights.
- Running stop signs and red lights.
- Improper passing.

These effects mean increased chances of an accident and chances of losing your driver’s license. Statistics show that the chance of an accident is much greater for drivers who have been drinking than for drivers who were not.

### The Truth About Alcohol

<b>FALSE</b>	<b>TRUE</b>
<ul style="list-style-type: none"> <li>• Alcohol increases your ability to drive.</li> <li>• Some people can drink a lot and not be affected by it.</li> <li>• If you eat a lot first, you will not get drunk.</li> <li>• Coffee and a little fresh air will help a drinker sober up.</li> <li>• Stick with beer – it is not as strong as wine or whiskey.</li> </ul>	<ul style="list-style-type: none"> <li>• Alcohol is a drug that will make you less alert and reduce your ability to drive safely.</li> <li>• Everyone who drinks is affected by alcohol.</li> <li>• Food will not keep you from getting drunk.</li> <li>• Only time will help a drinker sober up – other methods just do not work.</li> <li>• A few beers are the same as a few shots of whiskey or a few glasses of wine.</li> </ul>

**Other Drugs** — Besides alcohol, other legal and illegal drugs are being used more often. Laws prohibit the possession or use of many drugs while on duty. They prohibit being under the influence of any “controlled substance,” an amphetamine (including “pep pills” and “bennies”), methamphetamine, narcotics or any other substance that can make the driver unsafe. This could include a variety of prescription and over-the-counter drugs (cold medicines) that may make the driver drowsy or otherwise affect safe driving ability. However, possession and use of a drug given to a driver by a doctor is permitted if the doctor informs the driver that it will not affect safe driving ability.

Pay attention to warning labels of legitimate drugs and medicines and to doctor’s orders regarding possible effects. Stay away from illegal drugs. Do not use any drug that hides fatigue — **the only cure for fatigue is rest**. Alcohol can make the effects of other drugs much worse. The safest rule is do not mix drugs with driving at all.

Use of drugs can lead to traffic accidents resulting in death, injury and property damage. Furthermore, it can lead to arrest, fines and jail sentences. It can also mean the end of a person’s driving career.

**Illness** — Once in a while, you may become so ill that you cannot operate a motor vehicle safely. If this happens, **do not drive**. However, in case of an emergency, you may drive to the nearest place where you can safely stop.

## 2.20 Hazardous Materials Rules for all Commercial Drivers

All drivers should know something about hazardous materials. You must be able to recognize hazardous cargo and whether or not you can haul it without having a Hazardous Materials Endorsement added to your CDL license.

Hazardous materials are products that pose a risk to health, safety and property during transportation. Figure 2-15 below is the Hazardous Materials Table in the federal rules, which lists the nine different hazard classes. You must follow the many rules about transporting them. The intent of the rules is to:

- **Contain the product** – Many hazardous products can injure or kill on contact. To protect drivers and others from contact, the rules tell shippers how to package safely. Similar rules tell drivers how to load, transport and unload bulk tanks. These are containment rules.
- **Communicate the risk** – The shipper uses a shipping paper and package labels to warn dockworkers and drivers of the risk. Shipping orders, bills of lading and manifests all are examples of shipping papers. The shipping paper

**Figure 2-15**  
**Hazardous Materials Hazard**  
**Class/Division Table**

Class #	Division #	Name of Class or Division	Example
1	1.1	Mass Explosives	Dynamite
	1.2	Project Hazards	Flares
	1.3	Mass Fire Hazards	Display Fireworks
	1.4	Minor Hazards	Ammunition
	1.5	Very Insensitive	Blasting Agents
	1.6	Extremely Insensitive	Explosive Devices
2	2.1	Flammable Gases	Propane
	2.2	Non-Flammable Gases	Helium
	2.3	Poisonous/Toxic Gases	Fluorine, Compressed
3	-	Flammable Liquids	Gasoline
4	4.1	Flammable Solids	Ammonium Picrate, Wetted
	4.2	Spontaneously Combustible	White Phosphorus
	4.3	Spontaneously Combustible When Wet	Sodium
5	5.1	Oxidizers	Ammonium Nitrate
	5.2	Organic Peroxides	Methyl Ethyl Ketone Peroxide
6	6.1	Poison (Toxic Material)	Potassium Cyanide
	6.2	Infectious Substances	Anthrax Virus
7	-	Radioactive	Uranium
8	-	Corrosives	Battery Fluid
9	-	Miscellaneous Hazardous Materials	Polychlorinated Biphenyls (PCBs)
-	-	ORM-D (Other Regulated Material-Domestic)	Food Flavorings, Medicines
-	-	Combustible Liquids	Fuel Oil

describes the hazardous materials being transported. Shippers put diamond-shaped hazard warning labels on most hazardous materials packages. These labels inform others of the hazard. If the diamond label will not fit on the container, shippers put the label on a tag. For example, compressed gas cylinders that will not hold a label will have tags or decals. See examples of labels in Figure 2-16 below.

**Shipping Papers** — After an accident or a hazardous material spill or leak, you may be injured and unable to communicate the hazards of the materials you are transporting. Firefighters and police can prevent or reduce the amount of damage or injury at the scene if they know what hazardous materials are being carried. Your life, and the lives of others, may depend on quickly locating the hazardous materials shipping papers. For that reason, you must tab shipping papers related to hazardous materials, or keep them on top of other shipping papers. You also must keep shipping papers:

- In a pouch on the driver's door, or
- In clear view within reach while driving, or
- On the driver's seat when out of the vehicle.

**Placards** — Placards are used to warn others of hazardous materials. Placards are signs put on the outside of a vehicle that identify the hazard class of the cargo. A placarded vehicle must have at least four identical placards. They are put on the front, rear and both sides (see Figure 9-4 on page 90). Placards must be readable from all four directions. They are 10 3/4-inches square, turned upright on a point, in a diamond shape. Cargo tanks and other bulk packaging display the ID number of their contents on placards or orange panels.

Not all vehicles carrying hazardous materials need to have placards. The rules about placards are in Section 9. You may drive a vehicle that carries hazardous materials if it does not require placards. If it requires placards, you must not drive it unless your driver's license has the Hazardous Materials Endorsement (HME).

**Hazardous Materials Endorsement** — The rules require all drivers of placarded vehicles to learn how to safely load and transport hazardous products. They must have a commercial driver's license with the Hazardous Materials Endorsement. To get the endorsement you must pass a written exam on information in Section 9. You also must obtain a Tank Endorsement if you transport hazardous products in a cargo tank on a truck larger than 26,000 pounds gross vehicle weight rating.

Drivers who need the HME must learn the placard rules. If you do not know if your vehicle needs placards, ask your employer. **It is against the law to drive a vehicle needing placards unless you have the HME.** When stopped, you will be cited and will not be allowed to drive your truck any further. It will cost you time and money. Failure to obtain a placard when needed will risk your life and others if you have an accident. Emergency help will not know of your hazardous cargo.

Hazardous materials drivers also must know which products they can load together and which they cannot. These rules also are in Section 9. Before loading a truck with more than one type of product, you must know if it is safe to load them together. If you do not know, ask your employer.

**Figure 2-16**  
**Examples of Shipping**  
**Labels**



## Test Your Knowledge

1. Common medicines for colds can make you sleepy. True or False?
2. What should you do if you do become sleepy while driving?
3. Coffee and a little fresh air will help a drinker sober up. True or False?
4. What is a hazardous materials placard?
5. Why are placards used?

**These questions may be on the written exam.  
If you cannot answer all of them, study Sections 2.19 and 2.20.**

## Section 3: Transporting Cargo Safely

You must understand basic cargo safety rules to get a CDL. If you load cargo wrong or do not secure it, it can be a danger to others and to yourself. Loose cargo that falls off a vehicle can cause traffic problems and others could be hurt or killed. Loose cargo could hurt or kill you during a quick stop or crash. Your vehicle could be damaged by overload. Steering could be affected by how a vehicle is loaded, making it more difficult to control the vehicle.

Whether or not you load and secure the cargo yourself, you are responsible for:

- Inspecting your cargo.
- Recognizing overloads and poorly balanced weight.
- Knowing your cargo is properly secured.

If you intend to carry hazardous material that requires placards on your vehicle, you also are required to have a hazardous materials endorsement. Section 9 includes information necessary to pass the hazardous materials test.

### 3.1 Inspecting Cargo

As part of your pre-trip inspection, make sure the truck is not overloaded and that the cargo is balanced and secured properly. Inspect the cargo and its securing devices again within 25 miles after beginning a trip. Make any adjustments needed. Check the cargo and securing devices as often as necessary during a trip to keep the load secure. A good habit is to inspect again:

- After you have driven for 3 hours or 150 miles.
- After every break you take during driving.

Federal, state and local regulations of weight, securement, cover and truck routes vary greatly from place to place. Know the regulations of where you will be driving.

### 3.2 Weight and Balance

You are responsible for not being overloaded. Following are definitions of weights:

- **Gross vehicle weight (GVW)** – Total weight of a single vehicle plus its load.
- **Gross combination weight (GCW)** – Total weight of a powered unit plus trailer(s) plus the cargo.
- **Gross combination weight rating (GCWR)** – Maximum GCW specified by the manufacturer for a specific combination of vehicles plus its load.
- **Axle weight** – Weight transmitted to the ground by one axle or one set of axles.
- **Tire load** – Maximum safe weight a tire can carry at a specified pressure. This rating is stated on the side of each tire.
- **Suspension systems** – Suspension systems have a manufacturer's weight capacity rating.
- **Coupling device capacity** – Coupling devices are rated for the maximum weight they can pull and/or carry.

**Legal Weight Limits** — You must keep weights within legal limits. States have maximums for GVWs, GCWs and axle weights. Often, maximum axle weights are set by a bridge formula, which permits less maximum axle weight for axles that are closer together. This is to prevent overloading bridges and roadways.

Overloading can have bad effects on steering, braking and speed control. Overloaded trucks must go very slow on upgrades. Worse, they may gain too much speed on downgrades. Stopping distance increases. Brakes can fail when forced to work too hard.

During bad weather or in mountains, it may not be safe to operate at legal maximum weights. Take this into account before driving.

**Do Not Be Top-Heavy** — The height of the vehicle's center of gravity is very important for safe handling. A high center of gravity (cargo piled up high or heavy cargo on top) means you are more likely to tip over. It is most dangerous in curves or if you have to swerve to avoid a hazard. It is very important to distribute the cargo so it is as low as possible. Put the heaviest parts of the cargo under the lightest parts.

**Balance the Weight** — Poor weight balance can make vehicle handling unsafe. Too much weight on the steering axle can cause hard steering and damage the steering axle and tires. Underloaded front axles (caused by shifting weight too far to the rear) can make the steering axle weight too light to steer safely. Too little weight on the driving axles can

cause poor traction. The drive wheels may spin easily. During bad weather, the truck may not be able to keep going. Weight that is loaded so there is a high center of gravity causes greater chance of rollover. On flat bed vehicles, there is also a greater chance that the load will shift to the side or fall off. Figure 3-1 below shows examples of the right and wrong way to balance cargo weight.

**Figure 3-1**  
**Load Cargo Correctly**

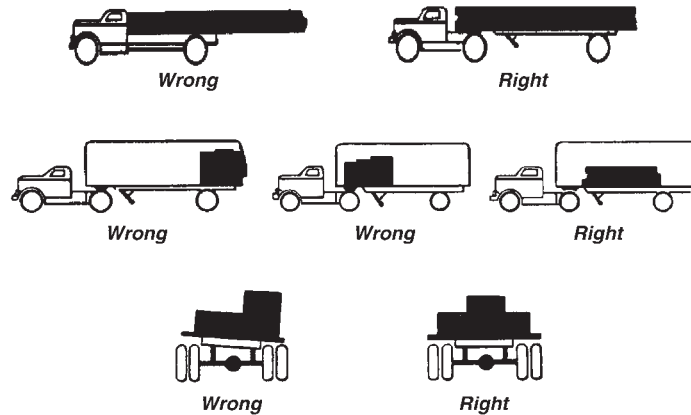

### Test Your Knowledge

1. For what three things related to cargo are drivers responsible?
2. How often must you stop while on the road to check your cargo?
3. How is **gross combination weight rating** different from **gross combination weight**?
4. Name two situations where legal maximum weights may not be safe.
5. What can happen if you do not have enough weight on the front axle?

**These questions may be on the written exam.**  
**If you cannot answer all of them, study Sections 3.1 and 3.2.**

### 3.3 Securing Cargo

**Blocking and Bracing** — **Blocking** is used in the front, back and/or sides of a piece of cargo to keep it from sliding. Blocking is shaped to fit snugly against cargo. It is secured to the cargo deck to prevent cargo movement. **Bracing** also is used to prevent movement of cargo. Bracing goes from the upper part of the cargo to the floor and/or walls of the cargo compartment.

**Cargo Tiedown** — On flat bed trailers or trailers without sides, cargo must be secured to keep it from shifting and falling off. In closed vans, tiedowns can also be important to prevent cargo shifting that may affect the handling of the vehicle. Tiedowns must be of the proper type and proper strength. The combined strength of all cargo tiedowns must be strong enough to lift one and one-half times the weight of the piece of cargo tied down. Proper tiedown equipment must be used, including ropes, straps, chains, and tensioning devices (winches, ratchets, clinching components). Tiedowns must be attached to the vehicle correctly (hook, bolt, rails, rings).

Cargo should have at least one tiedown for each 10 feet of cargo. Make sure you have enough tiedowns to meet this need. No matter how small the cargo is, it should have at least two tiedowns holding it.

There are special requirements for securing various heavy pieces of metal. Find out what they are if you are to carry such loads.

**Header Boards** — Front-end header boards (“headache racks”) protect you from your cargo in case of a crash or emergency stop. Make sure the front-end structure is in good condition and blocks the forward movement of any cargo you carry.

**Covering Cargo** — There are two basic reasons for covering cargo: (1) to protect people from spilled cargo, and (2) to protect the cargo from weather. Spill protection is a safety requirement in many states. Be familiar with the laws in the states you drive in.

Look at your cargo covers in the mirrors from time to time while driving. A flapping cover can tear loose, uncovering the cargo, and possibly blocking your view or someone else's.

You cannot inspect sealed loads, but you should check that you do not exceed gross weight and axle weight limits.

**Sealed and Containerized Loads** — Containerized loads generally are used when freight is carried part way by rail or ship. Delivery by truck occurs at the beginning and/or end of the journey. Some containers have their own tiedown devices or locks that attach directly to a special frame. Others have to be loaded onto flat bed trailers. They must be properly secured just like any other cargo.

### 3.4 Cargo Needing Special Attention

**Dry bulk tanks** require special care because they often have a high center of gravity, and the load can shift. Be extremely cautious (slow and careful) going around curves and making sharp turns.

**Hanging meat** (suspended beef, pork, lamb) in a refrigerated truck can be a very unstable load with a high center of gravity. Particular caution is needed on sharp curves such as off ramps and on ramps. Go slow.

**Livestock** can move around in a trailer, causing unsafe handling. With less than a full load, use false bulkheads to keep livestock bunched together. Even when bunched, special care is necessary because livestock can lean on curves. This shifts the center of gravity and makes rollover more likely.

**Over-length, over-width and/or overweight loads** require special transit permits. Driving is usually limited to certain times. Special equipment may be necessary, such as "wide load" signs, flashing lights, flags, etc. Such loads may require a police escort or pilot vehicles bearing warning signs and/or flashing lights. These special loads require special driving care. load them together. If you do not know, ask your employer.

#### Test Your Knowledge

1. What is the minimum number of tiedowns for any flat bed load?
2. What is the minimum number of tiedowns for a 20-foot load?
3. Name the two basic reasons for covering cargo on an open bed?
4. Name two situations where legal maximum weights may not be safe?

**These questions may be on the written exam.  
If you cannot answer all of them, study Sections 3.3 and 3.4.**



# Section 4: Transporting Passengers

A bus driver must have a CDL if he/she drives a vehicle designed to seat more than 16 persons, including the driver. A bus driver must have a Passenger Endorsement on his/her CDL. To obtain the endorsement, you must pass a knowledge test on Sections 2 and 4 of this manual. (If the bus has air brakes, you also must pass a knowledge test on Section 5.) You also must pass the skills tests required for the class of vehicle you drive.

## 4.1 Pre-Trip Inspection

Before driving your bus, make sure it is safe. During the pre-trip inspection, check defects reported by previous drivers. Only if defects reported earlier have been repaired should you sign the previous driver's report. This is your certification that the defects reported earlier have been repaired.

**Vehicle Systems** — Make sure the following are in good working order before driving:

- Service brakes, including air hose couplings (if your bus has a trailer or semitrailer).
- Parking brake.
- Steering mechanism.
- Lights and reflectors.
- Tires (front wheels must not have recapped or regrooved tires).
- Horn.
- Windshield wiper or wipers.
- Rear-vision mirror or mirrors.
- Coupling devices (if present).
- Wheels and rims.
- Emergency equipment.

**Access Doors and Panels** — As you check the outside of the bus, close any open emergency exits. Also, close any open access panels (for baggage, restroom service, engine, etc.) before driving.

**Bus Interior** — People sometimes damage unattended buses. Always check the interior of the bus before driving to ensure rider safety. Aisles and stairwells must always be clear. The following parts of your bus must be in safe working condition:

- Each handhold and railing.
- Floor covering.
- Signaling devices, including the restroom emergency buzzer, if the bus has a restroom.
- Emergency exit handles.

The seats must be safe for riders. All seats must be securely fastened to the bus.

Never drive with an open emergency exit door or window. The Emergency Exit sign on an emergency door must be clearly visible. If there is a red emergency door light, it must work. Turn it on at night or any other time you use your outside lights.

**Roof Hatches** — You may lock some emergency roof hatches in a partly open position for fresh air. Do not leave them open as a regular practice. Keep in mind the bus's higher clearance while driving with them open.

Make sure your bus has the fire extinguisher and emergency reflectors required by law. The bus must also have spare electrical fuses unless equipped with circuit breakers.

**Safety Belt** — The driver's seat should have a safety belt. Always buckle up. (You must also pass the skills tests required for the class of vehicle you drive.)

## 4.2 Loading and Trip Start

Do not allow riders to leave carry-on baggage in a doorway or aisle. There should be nothing in the aisle that might trip other riders. Secure baggage and freight in ways that avoid damage and:

- Allow the driver to move freely and easily.
- Allow riders to exit by any window or door in an emergency.
- Protect riders from injury if carryons fall or shift.

**Hazardous Materials** — Watch for cargo or baggage containing hazardous materials. Most hazardous materials cannot be carried on a bus. Riders sometimes board a bus with an unlabeled hazardous material. They may not know it is unsafe. Do not allow riders to carry on common hazards such as car batteries or gasoline.

The Federal Hazardous Materials Table on page 49 shows which materials are hazardous. They pose a risk to health, safety and property during transportation. The rules require shippers to mark containers of hazardous material with the material's name, ID number and hazard label. There are nine different 4-inch, diamond-shaped hazard labels like the examples shown in Figure 4-1 below. A chart showing all the labels is in the back of this manual. Watch for the diamond-shaped labels. Do not transport any hazardous material unless you are sure the rules allow it.

**Forbidden Hazardous Materials** — Buses may carry small-arms ammunition, emergency shipments of drugs, chemicals and hospital supplies. You can carry small amounts of some other hazardous materials if the shipper cannot send them any other way. Buses must never carry:

- Division 2.3 POISONOUS (Toxic) GAS.
- Division 6.1 EXTREMELY DANGEROUS POISONOUS (Toxic) LIQUID.
- Paranitroaniline.
- More than 45 kg. (99 pounds) of a solid Division 6.1 Poison.
- More than 225 kg. (496 pounds) total of allowable hazardous materials and no more than 45 kg. (99 pounds) of any one class.

**Figure 4-1**  
**Examples of Labels**



**Standee Line** — No rider may stand forward of the rear of the driver's seat. Buses designed to allow standing must have a 2-inch line on the floor or some other means of showing riders where they cannot stand. This is called the standee line. All standing riders must stay behind it.

When arriving at the destination or intermediate stops, announce:

- The location,
- Reason for stopping,
- Next departure time, and
- Bus number.

Remind riders to take carry-ons with them if they get off the bus. If the aisle is on a lower level than the seats, remind riders of the step down. It is best to tell them before coming to a complete stop.

Charter bus drivers should not allow riders on the bus until departure time. This will help prevent theft or vandalism of the bus.

## Test Your Knowledge

1. Name some things to check in the interior of a bus during pre-trip inspection?
2. What are some hazardous materials you can transport by bus?
3. What are some hazardous materials you cannot transport by bus?
4. What is a standee line?
5. What three kinds of emergency equipment must you have?
6. What is the minimum tread depth for front tires?
7. For other tires?

**These questions may be on the written exam.  
If you cannot answer all of them, study Sections 4.1 and 4.2.**

## 4.3 On The Road

**Passenger Supervision** — Many charter and intercity carriers have passenger comfort and safety rules. Mention rules about smoking, drinking or use of cell phones and other electronic devices at the start of the trip. Explaining the rules at the start will help to avoid trouble later on.

While driving, scan the interior of your bus as well as the road ahead, to the sides, and to the rear. You may have to remind riders about rules or to keep arms and heads inside the bus.

**At Stops** — Riders can stumble when getting on or off and when the bus starts or stops. Caution riders to watch their step when leaving the bus. Wait for them to sit down or brace themselves before starting. Starting and stopping should be as smooth as possible to avoid rider injury.

Occasionally, you may have a drunk or disruptive rider. You must ensure this rider's safety as well as that of others. Do not discharge such riders where it would be unsafe for them. It may be safer at the next scheduled stop or a well-lighted area where there are other people. Many carriers have guidelines for handling disruptive riders

**Common Accidents** — Bus accidents often happen at intersections. Use caution, even if a signal or stop sign controls other traffic. School and mass transit buses sometimes scrape off mirrors or hit passing vehicles when pulling out from a bus stop. Remember the clearance your bus needs, and watch for poles and tree limbs at stops. Know the size of the gap your bus needs to accelerate and merge with traffic. Wait for the gap to open before leaving the stop. Never assume other drivers will brake to give you room when you signal or start to pull out.

**Speed on Curves** — Accidents on curves that kill people and destroy buses result from excessive speed, often when rain or snow has made the road slippery. Every banked curve has a safe "design speed." In good weather, the posted speed is safe for cars, but it may be too high for many buses. With good traction, the bus may roll over; with poor traction, it might slide off the curve. **Reduce speed for curves.** If your bus leans toward the outside on a banked curve, you are driving too fast.

**Railroad Crossings** — Bus drivers are required to stop between 15 and 50 feet before railroad crossings. Listen and look in both directions for trains. You should open your forward door if it improves your ability to see or hear an approaching train. Before crossing after a train has passed, make sure there is not another train coming in the other direction on other tracks. If your bus has a manual transmission, never change gears while crossing the tracks.

You do not have to stop, but you must slow down and carefully check for other vehicles:

- At street car crossings.
- At railroad tracks used only for industrial switching within a business district.
- Where a policeman or flagman is directing traffic.
- If a traffic signal shows green.
- At crossings marked "exempt" or "abandoned."

**Drawbridges** — Bus drivers are required to stop at drawbridges that do not have a signal light or traffic control attendant. Stop at least 50 feet before the draw of the bridge. Look to make sure the draw is completely closed before crossing.

You do not need to stop, but you must slow down and make sure it is safe when:

- there is a traffic light showing green.
- the bridge has an attendant or traffic officer that controls traffic whenever the bridge opens.

#### **4.4 After-Trip Vehicle Inspection**

Inspect your bus at the end of each shift. If you work for an interstate carrier, you must complete a written inspection report for each bus driven. The report must specify each bus and list any defect that would affect safety or result in a breakdown. If there are no defects, the report should say so.

Riders sometimes damage safety-related parts such as hand-holds, seats, emergency exits and windows. If you report this damage at the end of a shift, mechanics can make repairs before the bus goes out again. Mass transit drivers should also make sure passenger signaling devices and brake-door interlocks work properly.

#### **4.5 Prohibited Practices**

- Avoid fueling your bus with riders on board unless absolutely necessary. Never refuel in a closed building with riders on board.
- Do not talk with riders or engage in any other distracting activity while driving.
- Do not tow or push a disabled bus with riders aboard either vehicle, unless getting off the bus would be unsafe. Only tow or push the bus to the nearest safe spot to discharge passengers. Follow your employer's guidelines on towing or pushing disabled buses.

#### **4.6 Brake-Door Interlocks**

Urban mass transit coaches may have a brake and accelerator interlock system. The interlock applies the brakes and holds the throttle in idle position when the rear door is open. The interlock releases when you close the rear door. Do not use this safety feature in place of the parking brake.

## Section 4-A: Charter Bus Endorsement

A CDL holder wanting a Charter Bus Endorsement — an endorsement for the sole purpose of transporting students in grades 12 and below under a single contract at a fixed rate for the exclusive use of the vehicle when used for a school-sponsored activity — must first pass the knowledge exam based on Sections 2 and 4 of this manual. (If your bus has air brakes, you also must pass the air brake exam based on Section 5.) You must pass the skills and driving exams in a representative vehicle of the license class for which you are applying.

**Requirements** — A driver must:

- Be age 21 or older.
- Possess a valid and properly classified driver's license issued by the Secretary of State.
- Submit to and successfully pass an Illinois specific criminal background check through an approved vendor.
- Complete a medical examination, including chemical testing for drugs. A current IDOT medical card is acceptable.
- Successfully pass a written charter bus endorsement exam administered by the Secretary of State.
- Successfully pass a driving exam, if applicable, in a representative vehicle of the class of the driver's license for passenger and charter bus endorsements.
- Affirm under penalties of perjury that you have not made a false statement or knowingly concealed a material fact in any application for a charter bus endorsement.

**Safety Information** —

- When entering or exiting an expressway, do so as quickly and as safely as possible.
- Unless absolutely necessary, never bring your vehicle to a complete stop immediately before entering any high-speed expressway. Enter and merge as safely as possible with the flow of traffic.
- The emergency door must be unlocked (if lock-equipped) but securely latched when the school bus is in operation.
- The driver must not back a bus at the school while students are in the vicinity unless a responsible person is present to guide the bus driver.

## Section 4-B: School Bus Endorsement

A CDL holder wanting a School Bus Endorsement — an endorsement to drive a yellow school bus designed to seat more than 16 persons, including the driver — must first pass the knowledge exam based on Sections 2 and 4 of this manual. (If your bus has air brakes, you also must pass the air brake exam based on Section 5.) You must pass the skills and driving exams in the school bus of the license class for which you are applying.

The school bus endorsement is required when transporting pre-primary, primary or secondary school students from home to school, from school to home, or to and from school sponsored events.

**CDL school bus drivers cannot legally operate a yellow school bus if they do not have the (S) School Bus Endorsement.**

**Requirements** — A driver must:

- Be age 21 or older.
- Possess a valid and properly classified driver's license issued by the Secretary of State.
- Possess a current medical card when required.
- Successfully pass a written school bus endorsement exam administered by the Secretary of State.
- Successfully pass a driving test, if applicable, in a representative vehicle of the license class for passenger and school bus endorsements.
- Not have been repeatedly involved as a driver in motor vehicle accidents or repeatedly convicted of traffic offenses, which indicates disrespect for traffic laws.
- In Illinois, prior to issuance of the first permit and annually thereafter, a school bus driver must meet the physical requirements as defined in 92 Ill. Adm. Code, Section 1035.20.

**Safety Information** —

**Pre-trip inspection:** Each day that a school bus is operated the driver must conduct a pre-trip inspection of the mechanical and safety equipment on the bus. A person other than the driver may perform the pre-trip inspection as prescribed by administrative rule. The driver is required to complete a School Bus Driver's Pre-Trip Inspection form each time an inspection is performed. Any defects found on the bus must be recorded on the form.

**Speed limits:** The legal speed limit for a school bus is the same as that for an automobile. However, because of the size and weight of a school bus, it requires a greater stopping distance than a regular passenger vehicle. Adjust your speed for the time of day, weather and road conditions.

**Entering or exiting an expressway:** When entering or exiting an expressway, do so as quickly and as safely as possible. Unless absolutely necessary, never bring your vehicle to a complete stop immediately before entering any high-speed expressway. Enter and merge as safely as possible with the flow of traffic.

**Get them there safely:** Proper use of safety devices on the school bus will help you control traffic when stopped to load and unload students.

- The amber lights of the 8-lamp flashing signal system must be activated when approaching a stop at least:
  1. 100 feet within an urban area
  2. 200 feet outside an urban area
- No child may cross any highway with four or more lanes of traffic where at least one or more lanes travel in the opposite direction. The school bus stop must be situated so that the student's residence and/or school (attendance center) is on the right side of the highway.
- The driver must let students off the school bus only at their assigned stops. While this practice is designed to provide the highest level of protection for you and your passengers, restricting additional stops also will save fuel.  
**Do not change routes or pick-ups without authorization from the proper school official.**
- The service door must be closed at all times when the bus is in motion.
- The emergency door must be unlocked (if lock-equipped) but securely latched when the school bus is in operation.
- The manufacturer's capacity for a bus must not be exceeded.
- Students may not be asked to leave the bus along the route for breach of discipline, nor may they be asked to sit anywhere other than a seat for breach of discipline.
- The driver may not back a bus at the school while students are in the vicinity unless a responsible person is present to guide the bus driver.
- When unloading at school, the bus may be driven onto the school grounds to discharge pupils, or they should be discharged so they will not have to cross a street. At all discharge points where it is necessary for pupils to cross

a roadway, the driver must direct students to walk at least 10 feet in front of the bus on the shoulder of the highway and to remain there until a signal is given by the bus driver for the student to cross.

- The driver must not allow a student to get off the bus at any place other than the student's designated discharge point unless written permission is granted by the proper school official.
- The driver must stop between 15 and 50 feet of the first rail of a railroad crossing. While stopped, the driver must open the service door and driver's window, listen and look in both directions for any approaching train. When the driver determines that no train is approaching, he/she must close the door and proceed completely across the grade crossing in low gear.
- The driver's safety belt must always be properly fastened before putting the bus in motion.

### Test Your Knowledge

1. Does it matter where you make a disruptive passenger get off the bus?
2. How far from a railroad crossing should you stop?
3. When must you stop before crossing a drawbridge?
4. Describe the "prohibited practices."
5. The rear door of a transit bus has to be open to put on the parking brake. True or False?

**These questions may be on the written exam.  
If you cannot answer all of them,  
study Sections 4.3 through Sections 4-A and 4-B.**

4. Push in clutch and shift to the higher

## Section 5: Air Brakes

If you want to drive a truck or bus with air brakes or pull a trailer with air brakes, you need to study this section. If you want to pull a trailer with air brakes you also need to study Section 6: Combination Vehicles.

Air brakes use **compressed air** to make the brakes work. Air brakes are a good and safe way of stopping large and heavy vehicles when the brakes are well maintained and used properly.

Air brake systems combine three braking systems: service, parking and emergency brake systems.

1. The **service brake** system applies and releases the brakes when you use the brake pedal during normal driving.
2. The **parking brake** system applies and releases the parking brakes when you use the parking brake control.
3. The **emergency brake** system uses parts of the service and parking brake systems to stop the vehicle in the event of a brake system failure.

### 5.1 Parts of Air Brake System

There are many parts to an air brake system. You should know about the parts discussed here.

**Air Compressor** — The air compressor pumps air into the air storage tanks (reservoirs). The air compressor is connected to the engine through gears or a V-belt. The compressor may be air cooled or may be cooled by the engine cooling system. It may have its own oil supply or be lubricated by engine oil. If the compressor has its own oil supply, check the oil level before driving.

**Air Compressor Governor** — The governor controls when the air compressor will pump air into the air storage tanks. When air tank pressure rises to the “cut-out” level (around 125 pounds per square inch, or “psi”), the governor stops the compressor from pumping air. When the tank pressure falls to the “cut-in” pressure (around 100 psi), the governor allows the compressor to start pumping again.

**Air Storage Tanks** — Air storage tanks are used to hold compressed air. The number and size of air tanks vary among vehicles. The tanks will hold enough air to allow the brakes to be used several times even if the compressor stops working.

**Air Tank Drains** — Compressed air usually has some water and compressor oil in it, which is bad for the air brake system. For example, the water can freeze in cold weather and cause brake failure. The water and oil tend to collect in the bottom of the air tank. Be sure to drain the air tanks completely. Each air tank is equipped with a drain valve in the bottom. **There are two types of drain valves:**

1. Manually operated by turning a quarter turn (see Figure 5-1 on page 74) or by pulling a cable. You must drain the tanks yourself at the end of each day of driving.
2. Automatic, in which the water and oil are automatically expelled. They may be equipped for manual draining as well.

The automatic types are available with electric heating devices. These help prevent freeze-up of the automatic drain in cold weather.

**Figure 5-1**  
**Manual Drain Valve**

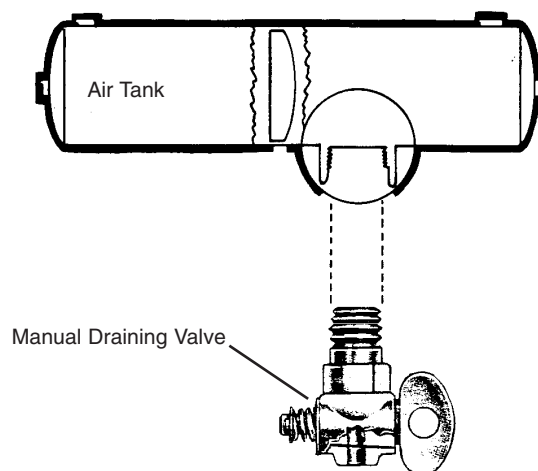



**Alcohol Evaporator** — Some air brake systems have an alcohol evaporator to put alcohol into the air system. This helps reduce the risk of ice in air brake valves and other parts during cold weather. Ice inside the system can make the brakes stop working.

Check the alcohol container and fill up as necessary every day during cold weather. **Daily air tank drainage is still needed to get rid of water and oil** (unless the system has automatic drain valves).

**Safety Valve** — A safety relief valve is installed in the first tank the air compressor pumps air to. The safety valve protects the tank and the rest of the system from too much pressure. The valve is usually set to open at 150 psi. If the safety valve releases air, something is wrong. Have the fault repaired by a mechanic.

**Brake Pedal** — You apply the brakes by pushing down the brake pedal (also called the “foot valve” or “treadle valve”). Pushing the pedal down harder applies more air pressure. Letting up on the brake pedal reduces the air pressure and releases the brakes. Releasing the brakes lets some compressed air go out of the system, so the air pressure in the tanks is reduced. It must be made up by the air compressor. Pressing and releasing the pedal unnecessarily can let air out faster than the compressor can replace it. If the pressure gets too low, the brakes will not work.

**Foundation Brakes** — Foundation brakes are used at each wheel. The most common type is the S-cam drum brake (see Figure 5-2 below). The parts of the brake are discussed below:

**Brake drums, shoes, linings:** Brake drums are located on each end of the vehicle’s axles. The wheels are bolted to the drums. The braking mechanism is inside the drum. To stop, the brake shoes and linings are pushed against the inside of the drum. This causes friction, which slows the vehicle (and creates heat). The heat a drum can take without damage depends on how hard and how long the brakes are used. Too much heat can make the brakes stop working.

**S-cam brakes:** When you push the brake pedal, air is let into each brake chamber (see Figure 5-2). Air pressure pushes the rod out, moving the slack adjuster, thus twisting the brake cam shaft. This turns the S-cam (named because it is shaped like the letter S). The S-cam forces the brake shoes away from one another and presses them against the inside of the brake drum. When you release the brake pedal, the S-cam rotates back, and a spring pulls the brake shoes away from the drum, letting the wheels roll freely again.

**Figure 5-2**  
**S-cam Air Brake**

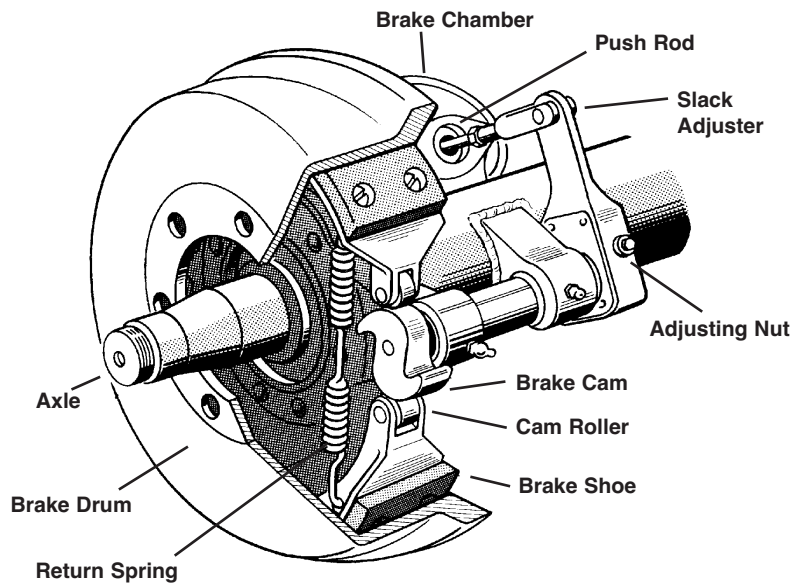

**Wedge brakes:** In these types of brakes, the brake chamber push rod pushes a wedge directly between the ends of two brake shoes. This shoves them apart and against the inside of the brake drum. Wedge brakes may have a single brake chamber or two brake chambers, pushing wedges in at both ends of the brake shoes. Wedge-type brakes may be self-adjusting or may require manual adjustment.

**Disc brakes:** In air-operated disc brakes, air pressure acts on a brake chamber and slack adjuster, like S-cam brakes. But instead of the S-cam, a “power screw” is used. The pressure of the brake chamber on the slack adjuster turns the power screw. The power screw clamps the disc or rotor between the brake lining pads of a caliper, similar to a large C-clamp.

The manual adjustment of automatic slack adjusters is dangerous because it gives the vehicle operator a false sense of security about the effectiveness of the braking system.

Wedge brakes and disc brakes are less common than S-cam brakes.

**Supply Pressure Gauges** — All air-brake vehicles have a pressure gauge connected to the air tank. If the vehicle has a dual air brake system, there will be a gauge for each half of the system (or a single gauge with two needles). Dual systems are discussed on page 65. These gauges tell you how much pressure is in the air tanks.

**Application Pressure Gauge** — This gauge shows how much air pressure you are applying to the brakes. (This gauge is not on all vehicles.) Increasing application pressure to hold the same speed means the brakes are fading. You should slow down and use a lower gear. The need for increased pressure also can be caused by brakes out of adjustment, air leaks or mechanical problems.

**Low Air-Pressure Gauge** — A low air-pressure warning signal is required on vehicles with air brakes. A warning signal you can see must come on before the air pressure in the tanks falls below 60 psi (or one-half the compressor governor cutout pressure on older vehicles). The warning is usually a red light. A buzzer also may come on.

Another type of warning is the “wig wag.” This device drops a mechanical arm into your view when the pressure in the system drops below 60 psi. An automatic wig wag will rise out of your view when the pressure in the system goes above 60 psi. The manual reset type must be placed in the “out of view” position manually. It will not stay in place until the pressure in the system is above 60 psi.

On large buses it is common for the low-pressure warning devices to signal at 80-85 psi.

**Stop Light Switch** — Drivers behind you must be warned when you put your brakes on. The air brake system does this with an electric switch that works by air pressure. The switch turns on the brake lights when you put on the air brakes.

**Front Brake Limiting Valve** — Some older vehicles (made before 1975) have a front brake limiting valve and a control in the cab. The control is usually marked “normal” and “slippery.” When you put the control in the “slippery” position, the limiting valve cuts the “normal” air pressure to the front brakes by half. Limiting valves were used to reduce the chance of the front wheels skidding on slippery surfaces. However, they actually reduce the stopping power of the vehicle. Front-wheel braking is good under all conditions. Tests show that front-wheel skids from braking are not likely even on ice. **Make sure the control is in the “normal” position to have normal stopping power.**

Many vehicles have automatic front-wheel limiting valves. They reduce the air to the front brakes except when the brakes are put on very hard (60 psi or more application pressure). These valves cannot be controlled by the driver.

**Spring Brakes** — All trucks, truck tractors and buses must be equipped with emergency brakes and parking brakes. They must be held on by mechanical force because air pressure can eventually leak away. Spring brakes are usually used to meet these needs. When driving, powerful springs are held back by air pressure. If the air pressure is removed, the springs put on the brakes. A parking brake control in the cab allows the driver to let the air out of the spring brakes. This lets the springs put the brakes on. A leak in the air brake system, which causes all the air to be lost, will also cause the springs to put on the brakes.

Tractor and straight truck spring brakes will come on fully when air pressure drops to a range of 20 to 45 psi (typically 20 to 30 psi). Do not wait for the brakes to come on automatically. When the low air-pressure warning light and buzzer first come on, bring the vehicle to a safe stop right away while you can still control the brakes.

The braking power of spring brakes depends on the brakes being in adjustment. If the brakes are not adjusted properly, neither the regular brakes nor the emergency/parking brakes will work right.

**Parking Brake Controls** — In newer vehicles with air brakes, you apply the parking brakes using a **diamond-shaped, yellow, push-pull control knob**. You pull the knob out to put the parking brakes (spring brakes) on, and push it in to release them. On older vehicles, the parking brakes may be controlled by a lever. Use the parking brakes whenever you park.

**Caution:** Never push the brake pedal down when the spring brakes are on. If you do, the brakes could be damaged by the combined forces of the springs and the air pressure. Many brake systems are designed so this will not happen. But not all systems are set up that way, and those that are may not always work. It is much better to develop the habit of not pushing the brake pedal down when the spring brakes are on.

**Modulating control valves:** In some vehicles a control handle on the dash board may be used to apply the spring brakes gradually. This is called a “modulating valve.” It is spring-loaded so you have a feel for the braking action. The more you move the control lever, the harder the spring brakes come on. They work this way so you can control the spring brakes if the service brakes fail. When parking a vehicle with a modulating control valve, move the lever as far as it will go and hold it in place with the locking device.

**Dual parking control valves:** When main air pressure is lost, the spring brakes come on. Some vehicles, such as buses, have a separate air tank that can be used to release the spring brakes so you can move the vehicle in an emergency. One of the valves is a push-pull type and is used to put on the spring brakes for parking. The other valve is spring-loaded in the “out” position. When you push the control in, air from the separate air tank releases the spring brakes so you can move. When you release the button, the spring brakes come on again. There is only enough air in the separate tank to do this a few times. Therefore, plan carefully when moving. Otherwise, you may be stopped in a dangerous location when the separate air supply runs out.

### Test Your Knowledge

1. Why must air tanks be drained?
2. What is a supply pressure gauge used for?
3. All vehicles with air brakes must have a low air-pressure warning signal. True or False?
4. What are spring brakes?
5. Front wheel brakes are good under all conditions. True or False?

**These questions may be on the written exam.  
If you cannot answer all of them, study Section 5.1.**

## 5.2 Dual Air Brake Systems

Most newer heavy-duty vehicles use dual air brake systems for safety. A dual air brake system has two separate air brake systems that use a single set of brake controls. Each system has its own air tanks, hoses, lines, etc. One system typically operates the regular brakes on the rear axle or axles. The other system operates the regular brakes on the front axle and possibly one rear axle. Both systems supply air to the trailer if there is one. The first system is called the “primary” system. The other is called the “secondary” system.

Before driving a vehicle with a dual air system, allow time for the air compressor to build up a minimum of 100 psi pressure in both the primary and secondary systems. Watch the primary and secondary air pressure gauges or needles if the system has two needles in one gauge. Pay attention to the low air-pressure warning light and buzzer. The warning light and buzzer should shut off when air pressure in both systems rises to a value set by the manufacturer. This value must be greater than 60 psi.

The warning light and buzzer should come on before the air pressure drops below 60 psi in either system. If this happens while driving, you should stop right away and safely park the vehicle. If one air system is very low on pressure, either the front or the rear brakes will not be operating fully. This means it will take you longer to stop. Bring the vehicle to a safe stop and have the air brake system fixed.

### 5.3 Inspecting Air Brake Systems

You should use the basic 7-Step Inspection Procedure described in Section 2 to inspect your vehicle. There are more items to inspect on a vehicle with air brakes than one without them. These items are discussed below, in the order that they fit into the 7-Step Method.

#### STEP 2: Engine Compartment Checks

**Check air compressor drive belt if compressor is belt driven.** If the air compressor is belt driven, check the condition and tightness of the belt. The belt should be in good condition.

#### STEP 5: Walkaround Inspection

**Check manual slack adjusters on S-Cam brakes:** Park on level ground and chock the wheels to prevent the vehicle from moving. Turn off the parking brakes so you can move the slack adjusters. Use gloves and pull hard on each slack adjuster that you can get to. If a slack adjuster moves more than about one inch where the push rod attaches to it, it probably needs adjusting. Vehicles with too much brake slack can be very hard to stop. Out-of-adjustment brakes are the most common problem found in roadside inspections. Be safe. Check the slack adjusters.

The manual adjustment of automatic slack adjusters is dangerous because it gives the vehicle operator a false sense of security about the effectiveness of the braking system.

**Check brake drums or discs, linings and hoses:** Brake drums or discs must not have cracks longer than one-half the width of the friction area. Linings (friction material) must not be loose or soaked with oil or grease. They must not be dangerously thin. Mechanical parts must be in place, not broken or missing. Check the air hoses connected to the brake chambers to make sure they are not cut or worn due to rubbing.

#### STEP 7: Final Air Brake Check

Do the following checks instead of the hydraulic brake check described in Section 2: Step 7 – Check Brake System.

**Test low pressure warning signal:** Shut the engine off when you have enough air pressure that the low-pressure warning signal is not on. Turn the electrical power on, and step on and off the brake pedal to reduce air tank pressure. The low air-pressure warning signal must come on before the pressure drops to less than 60 psi in the air tank, or the tank with the lowest air pressure in dual air systems.

If the warning signal does not work, you could lose air pressure and not know it. This could cause sudden emergency braking in a single circuit air system. In dual systems the stopping distance will be increased. Only limited braking can be done before the spring brakes come on.

**Check that spring brakes come on automatically:** Chock the wheels, release the parking brakes when you have enough air pressure to do it and shut the engine off. Step on and off the brake pedal to reduce the air tank pressure. The “parking brake” knob should pop out when the air pressure falls to the manufacturer’s specification, usually in a range between 20 and 40 psi. This causes the spring brakes to come on.

**Check rate of air pressure buildup:** When the engine is at operating RPM, the pressure should build from 85 to 100 psi within 45 seconds in dual air systems. (If the vehicle has larger than minimum air tanks, the buildup time can be longer and still be safe. Check the manufacturer’s specifications.) In single air systems (pre-1975), typical requirements are pressure build-up from 50 to 90 psi within 3 minutes with the engine at an idle speed of 600-900 RPM.

If air pressure does not build up fast enough, the pressure may drop too low during driving, requiring an emergency stop. Do not drive until you get the problem repaired.

**Test air leakage rate:** With a fully-charged air system (typically 125 psi), turn off the engine, release the service brake, and time the air pressure drop. The loss rate should be less than 2 psi in 1 minute for single vehicles and less than 3 psi in 1 minute for combination vehicles. Then apply 90 psi or more with the brake pedal. After the initial pressure drop, if the air pressure falls more than 3 psi in 1 minute for single vehicles and more than 4 psi for combination vehicles, the air loss rate is too much. Check for air leaks, and repair before driving the vehicle. Otherwise, you could lose your brakes while driving.

**Check air compressor governor cut-in and cut-out pressures:** Pumping by the air compressor should start at about 100 psi and stop at about 125 psi. (Check manufacturer’s specifications.) Run the engine at a fast idle. The air governor should cut out the air compressor at about the manufacturer’s specified pressure. The air pressure shown

by your gauge(s) will stop rising. With the engine idling, step on and off the brake to reduce the air tank pressure. The compressor should cut in at about the manufacturer's specified cut-in pressure. The pressure should begin to rise.

If the air governor does not work as described above, it may need to be repaired. A governor that does not work right may not keep enough air pressure for safe driving.

**Test parking brake:** Stop the vehicle, put the parking brake on, and gently pull against it in a low gear to test that the parking brake will hold.

**Test service brakes:** Wait for normal air pressure, release the parking brake, move the vehicle forward slowly (about 5 mph) and apply the brakes firmly using the brake pedal. Note any vehicle "pulling" to one side, unusual feel or delayed stopping action.

This test may show you problems that you otherwise would not know about until you needed the brakes on the road.

### Test Your Knowledge

1. What is a dual air brake system?
2. What are slack adjusters?
3. How can you check slack adjusters?
4. How can you test the low pressure warning signal?
5. How can you check that the spring brakes come on automatically?
6. What are the maximum leakage rates?

**These questions may be on the written exam.  
If you cannot answer all of them, study Sections 5.2 and 5.3.**

## 5.4 Using Air Brakes

**Normal Stops** — To apply the air brakes during normal stops, push the brake pedal down. Control the pressure so the vehicle comes to a smooth, safe stop. If you have a manual transmission, do not push the clutch in until the engine RPM is down close to idle. When stopped, select a starting gear.

**Emergency Stops** — If somebody suddenly pulls out in front of you, your natural response is to hit the brakes. This is a good response if there is enough distance to stop and you use the brakes correctly.

You should brake in a way that will keep your vehicle in a straight line and allow you to turn if it becomes necessary. You can use the "controlled braking" method or the "stab braking" method.

**Controlled braking:** With this method, you apply the brakes as hard as you can without locking the wheels. Keep steering wheel movements very small while doing this. If you need to make larger steering adjustments or if the wheels lock, release the brakes. Reapply the brakes as soon as you can.

**Stab braking:** Use only on vehicles without anti-lock systems.

- Apply the brake all the way.
- Release the brakes when the wheels lock up.
- As soon as the wheels start rolling, put on the brakes fully again. (It can take up to 1 second for the wheels to start rolling after you release the brakes. If you reapply the brakes before the wheels start rolling, the vehicle will not straighten out.)

**Anti-lock Brakes** — New trucks and truck-trailer vehicles are equipped with anti-lock brakes. The anti-lock braking system is different than the normal air-brake system but works on the same principle.

Vehicles that have anti-lock brakes have a yellow light near the driver's rear side of the vehicle with the letters ABS stenciled above the light. Once the driver turns on the ignition, a yellow malfunction lamp on the instrument panel will light up, briefly indicating that the vehicle has anti-lock brakes. This lamp will remain constant if there is a malfunction in the anti-lock brake system.

For normal or emergency stopping using anti-lock brakes, the driver's foot remains on the brake pedal in which the anti-lock module then acts as a foot pumping the air brake system. On the air-brake system the driver must pump or use stab braking in an emergency. If the anti-lock brake system fails or malfunctions, the driver must resort to stopping the vehicle by using the normal air-brake method. If an emergency arises, the driver should use the controlled or stab-braking method. The anti-lock brake system should be serviced as soon as possible.

**Stopping Distance** — Stopping distance was discussed in Section 2: Speed and Stopping Distance. With air brakes, there is an added delay – the time required for the brakes to work after the brake pedal is pushed. With hydraulic brakes (used on cars and light/medium trucks), the brakes work instantly. However, with air brakes, it takes a little time (one-half second or more) for the air to flow through the lines to the brakes. Thus, the total stopping distance for vehicles with air brake systems is made up of four different factors:

Perception Distance  
+ Reaction Distance  
+ Brake Lag Distance  
+ Effective Braking Distance  
= Total Stopping Distance

The air brake lag distance at 55 mph on dry pavement adds about 32 feet. Therefore, for an average driver traveling 55 mph under good traction and brake conditions, the total stopping distance is more than 300 feet. This is longer than a football field.

**Brake Fading or Failure** — Brakes are designed so brake shoes or pads rub against the brake drum or discs to slow the vehicle. Braking creates heat, but brakes are designed to take a lot of heat. However, brakes can fade or fail from excessive heat caused by using them too much and not relying on the engine braking effect.

Excessive use of the service brakes results in overheating and leads to brake fade. Brake fade results from excessive heat causing chemical changes in the brake lining, which reduce friction and cause the expansion of the brake drums. As the overheated drums expand, the brake shoes and linings have to move further to contact the drums, and the force of this contact also is reduced. Continued overuse may increase brake fade until the vehicle cannot be slowed down or stopped at all.

Brake fade also is affected by adjustment. To safely control a vehicle, every brake must do its share of the work. Brakes out of adjustment will stop doing their share before those that are in adjustment. The other brakes can then overheat and fade and there will not be sufficient braking available to control the vehicle(s). Brakes can get out of adjustment quickly, especially when they are hot. Therefore, brake adjustment must be checked frequently.

**Proper Braking Technique** — Remember, the use of brakes on a long and/or steep downgrade is only a supplement to the braking effect of the engine. Once the vehicle is in the proper low gear, the following is the proper braking technique:

1. Apply the brakes just hard enough to feel a definite slowdown.
2. When your speed has been reduced to approximately 5 mph below your “safe” speed, release the brakes. (This brake application should last about 3 seconds.)
3. When your speed has increased to your “safe” speed, repeat steps 1 and 2.

For example, if your “safe” speed is 40 mph, you would not apply the brakes until your speed reaches 40 mph. You now apply the brakes hard enough to gradually reduce your speed to 35 mph and then release the brakes. Repeat this as often as necessary until you have reached the end of the downgrade

**Low Air Pressure** — If the low air pressure warning light comes on, **stop and safely park your vehicle as soon as possible**. There might be an air leak in the system. Controlled braking is possible only while enough air remains in the air tanks. The spring brakes will come on when the air pressure drops into the 20 to 45 psi range. A heavily loaded vehicle will take a long distance to stop because the spring brakes do not work on all axles. Lightly loaded vehicles or vehicles on slippery roads may skid out of control when the spring brakes come on. It is much safer to stop while there is enough air in the tanks to use the foot brake.

**Parking Brakes** — **Any time you park, use the parking brakes**, except as noted. Pull the parking brake control knob out to apply the parking brakes. Push it in to release them. The control will be a yellow, diamond-shaped knob labeled “parking brakes” on newer vehicles. On older vehicles, it may be a round blue knob or some other shape, including a lever that swings from side to side or up and down.

Do not use the parking brakes if the brakes are very hot (i.e., from just coming down a steep grade), or if the brakes

are very wet in freezing temperatures. If the brakes are used when very hot, they can be damaged by the heat. If they are used in freezing temperatures when the brakes are very wet, they can freeze so the vehicle cannot move. Use wheel chocks to hold the vehicle. Let hot brakes cool before using the parking brakes. If the brakes are wet, use the brakes lightly while driving in a low gear to heat and dry them.

If your vehicle does not have automatic air tank drains, drain your air tanks at the end of each working day to remove moisture and oil. Otherwise, the brakes could fail

**Never leave your vehicle unattended without applying the parking brakes or chocking the wheels. Your vehicle might roll away and cause injury and damage.**

### Test Your Knowledge

1. Why should you be in the proper gear **before** starting down a hill?
2. What factors can cause brakes to fade or fail?
3. The use of brakes on a long, steep downgrade is only a supplement to the braking effect of the engine. True or False?
4. If you are away from your vehicle only a short time, you do not need to use the parking brake. True or False?
5. How often should you drain air tanks?

**These questions may be on your written exam.  
If you cannot answer all of them, study Section 5.4.**

## Section 6: Combination Vehicles

This section provides information needed to pass the tests for combination vehicles (tractor-trailer, doubles, triples, straight truck and trailer). The information provides only the minimum knowledge needed for driving common combination vehicles. You should also study Section 7 if you need to pass the exams for doubles/triples.

### 6.1 Driving Combination Vehicles

Combination vehicles are usually heavier, longer and require more driving skill than single commercial vehicles. This means that drivers of combination vehicles need more knowledge and skill than drivers of single vehicles. In this section, important safety factors are discussed that apply specifically to combination vehicles.

**Rollover Risks** — More than half of truck driver deaths in accidents are the result of truck rollovers. When more cargo is piled up in a truck, the “center of gravity” moves higher up from the road. The truck becomes easier to turn over. Fully loaded rigs are 10 times more likely to roll over in a crash than empty rigs.

Two things will help prevent rollover: **keeping the cargo as close to the ground as possible, and going slowly while turning.** Keeping cargo low is even more important in combination vehicles than in straight trucks. Also, keep the load centered on your rig. If the load is to one side so it makes a trailer lean, a rollover is more likely. Make sure your cargo is centered and spread out as much as possible. (Cargo distribution is covered in detail in Section 3.)

Rollovers can happen when you turn too fast. Drive slowly around corners, on ramps and off ramps. Avoid quick lane changes, especially when fully loaded.

**Rearward Amplification** — Trucks with trailers have a dangerous “crack-the-whip” effect. When you make a quick lane change, the crack-the-whip effect can turn the trailer over. There are many accidents where only the trailer has overturned.

“Rearward amplification” causes the crack-the-whip effect. Figure 6-1 below shows eight types of combination vehicles and the rearward amplification each has in a quick lane change. Rigs with the least crack-the-whip effect are shown at the top, and those with the most at the bottom. Rearward amplification of 2.0 on the chart means that the rear trailer is twice as likely to turn over as the tractor. You can see that triples have a rearward amplification of 3.5. This means you can roll the last trailer of triples 3.5 times as easily as a 5-axle tractor-semi.

**Figure 6-1**  
Influence of Combination Type  
on Rearward Amplification

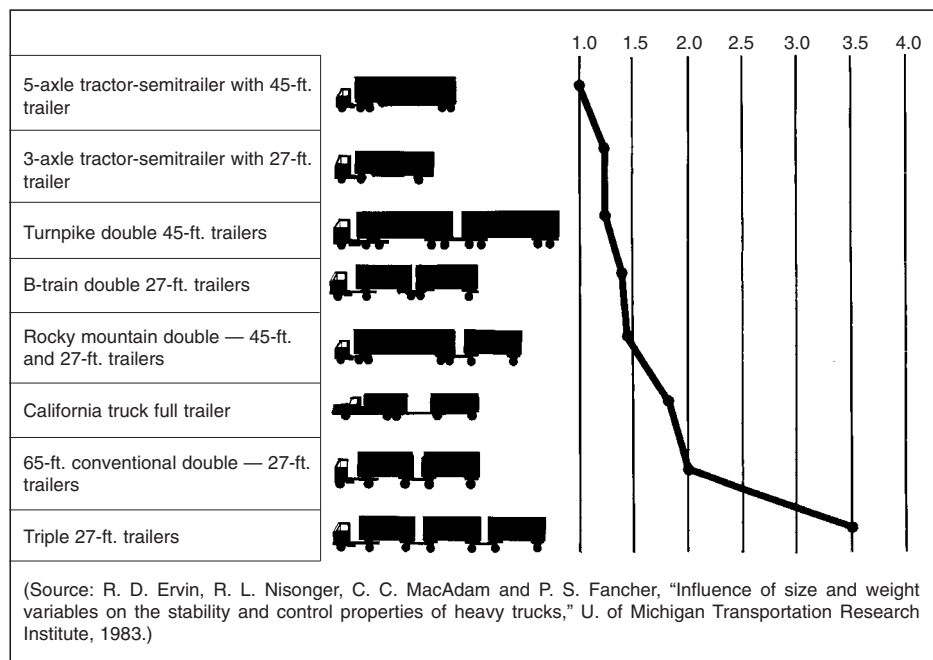

**Steer Gently** — Steer gently and smoothly when pulling trailers. If you make a sudden movement with your steering wheel, you could tip over. Follow far enough behind other vehicles (at least 1 second for each 10 feet of your vehicle length, plus another second if going over 40 mph). Look far enough down the road to avoid being surprised and having



to make a sudden lane change. At night, drive slow enough to see obstacles with your headlights before it is too late to change lanes or stop gently. Slow down to a safe speed before going into a turn.

**Brake Early** — Control your speed whether fully loaded or empty. Large combination vehicles take longer to stop when they are empty than when they are fully loaded. When lightly loaded, the very stiff suspension springs and strong brakes give poor traction and make it very easy to lock up the wheels. Your trailer can swing out and strike other vehicles. Your tractor can jackknife very quickly (see Figure 6-2 below). You also must be very careful about driving “bobtail” tractors (tractors without semitrailers). Tests show that bobtails can be very hard to stop smoothly. It takes them longer to stop than a tractor-semitrailer loaded to maximum gross weight.

In any combination rig, allow lots of following distance and look far ahead so you can brake early. Do not be caught by surprise and have to make a “panic” stop.

**Prevent Trailer Skids** — When the wheels of a trailer lock up, the trailer will tend to swing around. This is more likely to happen when the trailer is empty or lightly loaded. This type of jackknife is often called a “trailer jackknife” (see Figure 6-3 below).

Following is the procedure for stopping a trailer skid:

1. **Recognize the skid.** The earliest and best way to recognize that the trailer has started to skid is by seeing it in your mirrors. Any time you apply the brakes hard, check the mirrors to make sure the trailer is staying where it should be. Once the trailer swings out of your lane, it is very difficult to prevent a jackknife.
2. **Stop using the brake.** Release the brakes to get traction back. **Do not** use the trailer hand brake (if you have one) to “straighten out the rig.” This is the wrong thing to do because the brakes on the trailer wheels caused the skid in the first place. Once the trailer wheels grip the road again, the trailer will start to follow the tractor and straighten out.

**Figure 6-2**  
**Tractor Jackknife**

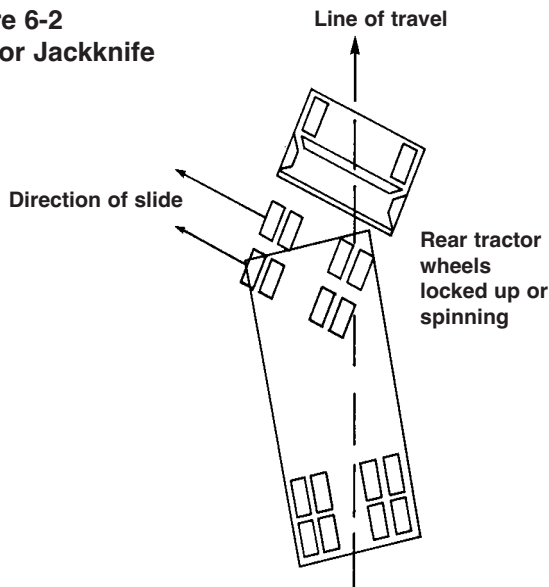

**Figure 6-3**  
**Trailer Jackknife**

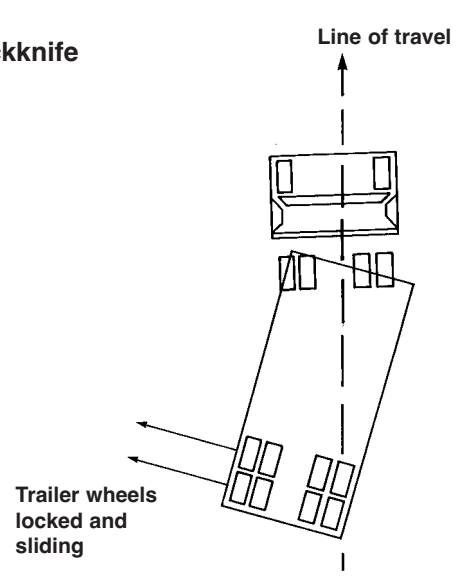

**Turn Wide** — When a vehicle goes around a corner, the rear wheels follow a different path than the front wheels. This is called “**offtracking**” or “cheating.” Figure 6-4 on page 72 shows how offtracking causes the path followed by a tractor-semi to be wider than the rig itself. Longer vehicles will offtrack more. The rear wheels of the powered unit (truck or tractor) will offtrack some, and the rear wheels of the trailer will offtrack even more. Steer the front end wide enough around a corner so the rear end does not run over the curb, pedestrians, other vehicles, etc. However, keep the rear of your vehicle close to the curb. This will stop other drivers from passing you on the right.

If you cannot complete your turn without entering another traffic lane, turn wide as you complete the turn (see Figure 6-5 on page 72). This is better than swinging wide to the left before starting the turn because it will keep other drivers from passing you on the right. If drivers pass on the right, you may collide with them when you turn.

**Figure 6-4**  
**Off-tracking in a**  
**90-degree turn**

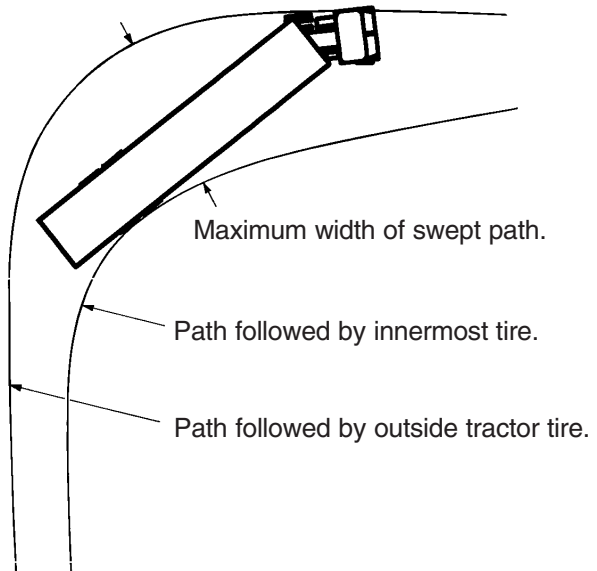

**Figure 6-5**  
**Turn wide as you**  
**complete the turn**

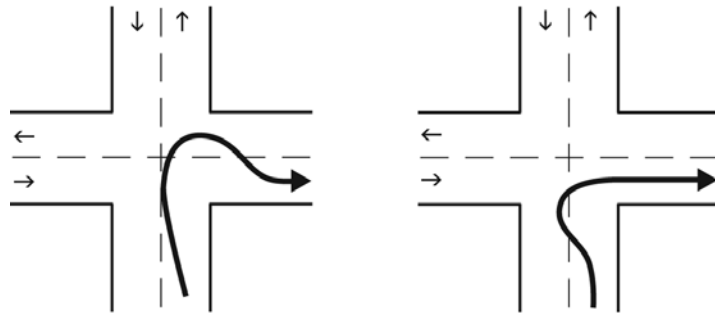

**Do this so vehicles do not**  
**try to pass you on the right.**

**Do not do this.**

**Test Your Knowledge**

1. What two things are important to prevent rollover?
2. When you turn suddenly while pulling doubles, which trailer is most likely to turn over?
3. Why should you not use the trailer hand brake to straighten out a jackknifing trailer?
4. What is off-tracking?
5. Why should you turn as shown in Figure 6-5?

**These questions may be on the written exam.**  
**If you cannot answer all of them, study Section 6.1.**

## 6.2 Combination Vehicle Air Brakes

**Before reading this section, you should study Section 5: Single Vehicle Air Brakes.** In combination vehicles, the braking system has parts to control the trailer brakes, in addition to the parts described in Section 5. These parts are described below.

**Trailer Hand Valve** — The trailer hand valve (also called the “trolley valve” or “Johnson bar”) works the trailer brakes. The trailer hand valve should be used only to test the trailer brakes. **Do not** use it in driving because of the danger of making the trailer skid. The foot brake sends air to **all** the brakes on the vehicle (including the trailer(s)). There is much less danger of causing a skid or jackknife when using just the foot brake.

Never use the hand valve for parking because all the air might leak out, unlocking the brakes (in trailers that do not have spring brakes.) Always use the **parking brakes** when parking. If the trailer does not have spring brakes, use wheel chocks to keep the trailer from moving.

**Tractor Protection Valve** — The tractor protection valve keeps air in the tractor or truck should the trailer break away or develop a bad leak. The tractor protection valve is controlled by the “trailer air supply” control valve in the cab. The control valve allows you to open and shut the tractor protection valve. The tractor protection valve will close automatically if air pressure is low (in the range of 20 to 45 psi). When the tractor protection valve closes, it stops any air from going out of the tractor. It also lets the air out of the trailer emergency line. This causes the trailer emergency brakes to come on. (Emergency brakes are covered later.)

**Trailer Air Supply Control** — The trailer air supply control on newer vehicles is a red 8-sided knob used to control the tractor protection valve. Push it in to supply the trailer with air, and pull it out to shut the air off and put on the trailer emergency brakes. The valve will pop out, thus closing the tractor protection valve, when the air pressure drops into the range 20 to 45 psi. Tractor protection valve controls or “emergency” valves on older vehicles may not operate automatically. There may be a lever rather than a knob. The “normal” position is used for pulling a trailer. The “emergency” position is used to shut the air off and put on the trailer emergency brakes.

**Trailer Air Lines** — Every combination vehicle has two air lines: the **service line** and the **emergency line**. They run between each vehicle (tractor to trailer, trailer to dolly, dolly to second trailer, etc.).

**Service air line:** The service line (also called the “control line” or “signal line”) carries air controlled by the foot brake or the trailer hand brake. Depending on how hard you press the foot brake or hand valve, the pressure in the service line will similarly change. The service line is connected to **relay valves**. These valves allow the trailer brakes to be applied more quickly than would otherwise be possible.

**Emergency air line:** The emergency line (also called the supply line) has two purposes: (1) To supply air to the trailer air tanks, and (2) to control the emergency brakes on combination vehicles. **Loss of air pressure** in the emergency line causes the trailer emergency brakes to come on. The pressure loss could be caused by a trailer breaking loose, thus tearing apart the emergency air hose. Or it could be caused by a hose, metal tubing or other part that breaks, letting the air out. When the emergency line loses pressure, it also causes the tractor protection valve to close (the air supply knob will pop out).

Emergency lines are often coded with the color **red** (red hose, red couplers or other parts) to keep from getting them mixed up with the **blue** service line.

**Hose Couplers (Glad Hands)** — “Glad hands” are coupling devices used to connect the service and emergency air lines from the truck or tractor to the trailer. The couplers have a rubber seal that prevents air from escaping.

Clean the couplers and rubber seals before a connection is made. When connecting the glad hands, press the two seals together with the couplers at a 90-degree angle to each other. A turn of the glad hand attached to the hose will join and lock the couplers.

Some vehicles have “dead end” or dummy couplers to which the hoses may be attached when they are not in use. This will prevent water and dirt from getting into the coupler and the air lines. Use the dummy couplers when the air lines are not connected to a trailer. If there are no dummy couplers, the glad hands can sometimes be locked together (depending on the couplings). It is very important to keep the air supply clean.

When coupling, be sure to couple the proper glad hands together. To help avoid mistakes, colors are sometimes used. **Blue** is used for the service lines, and red for the emergency (supply) lines. Sometimes, metal tags are attached to the lines with the words “service” and “emergency” stamped on them.

If you do cross the air lines, supply air will be sent to the service line instead of going to charge the trailer air tanks. Air will not be available to release the trailer spring brakes (parking brakes). If the spring brakes do not release when you push the trailer air supply control, check the air line connections.

Older trailers do not have spring brakes. If the air supply in the trailer air tank has leaked away, there will be no emergency brakes, and the trailer wheels will turn freely. If you crossed the air lines, you could drive away, but you would not have trailer brakes. **This would be very dangerous.** Always test the trailer brakes before driving with the hand valve or by pulling the air supply (tractor protection valve) control. Pull gently against them in a low gear to make sure the brakes work.

**Trailer Air Tanks** — Each trailer and converter dolly has one or more air tanks. They are filled by the **emergency (supply) line** from the tractor. They provide the air pressure used to operate trailer brakes. Air pressure is sent from the air tanks to the brakes by relay valves. The pressure in the **service line** tells how much pressure the relay valves should send to the trailer brakes. The pressure in the service line is controlled by the brake pedal and the trailer hand brake.

It is important not to let water and oil build up in the air tanks. If you do, the brakes may not work correctly. Each tank has a drain valve on it, and you should drain each tank every day. If your tanks have automatic drains, they will keep most moisture out, but you should still open the drains to make sure.

**Shut-off Valves** — Shut-off valves (also called “cut-out cocks”) are used in the service and supply air lines at the back of trailers used to tow other trailers. These valves permit closing the air lines off when another trailer is not being towed. You must check that all shut-off valves are in the **open** position except the ones at the back of the last trailer, which must be **closed**.

**Trailer Service, Parking and Emergency Brakes** — Newer trailers have spring brakes just like trucks and truck tractors. However, converter dollies and trailers built before 1975 are not required to have spring brakes. Those that do not have spring brakes have emergency brakes that work from the air stored in the trailer air tank. The emergency brakes come on whenever air pressure in the emergency line is lost. **These trailers have no parking brake.** The emergency brakes come on whenever the air supply knob is pulled out or the trailer is disconnected. But the brakes will hold only as long as there is air pressure in the trailer air tank. Eventually, the air will leak away, and then there will be no brakes. Therefore, **it is very important for safety that you use wheel chocks when you park trailers without spring brakes.**

A major leak in the **emergency** line will cause the tractor protection valve to close and the trailer emergency brakes to come on.

You may not notice a major leak in the **service** line until you try to put the brakes on. Then, the air loss from the leak will lower the air tank pressure quickly. If it goes low enough, the trailer emergency brakes will come on.

### Test Your Knowledge

1. Why should you not use the trailer hand valve while driving?
2. Describe what the trailer air supply control does.
3. Describe what the service line is for.
4. What is the emergency air line for?
5. Why should you use chocks when parking a trailer without spring brakes?
6. Where are shut-off valves?

**These questions may be on the written exam.  
If you cannot answer all of them, study Section 6.2.**

## 6.3 Coupling and Uncoupling

Knowing how to couple and uncouple correctly is basic to the safe operation of combination vehicles. Wrong coupling and uncoupling can be very dangerous. General coupling and uncoupling steps are listed below. There are differences between different rigs, so learn the details of coupling and uncoupling the truck(s) you will operate.

### COUPLING TRACTOR-SEMITRAILERS —

#### STEP 1: Inspect Fifth Wheel

- Check for damaged/missing parts.
- Check to see that mounting to tractor is secure, no cracks in frame, etc.
- Be sure that the fifth wheel plate is greased as required. Failure to keep the fifth wheel plate lubricated could cause steering problems because of friction between the tractor and trailer.
- Check if fifth wheel is in proper position for coupling:
  - Wheel tilted down towards rear of tractor.
  - Jaws open.
  - Safety unlocking handle in the automatic lock position.
- If you have a sliding fifth wheel, make sure it is locked.
- Make sure the trailer kingpin is not bent or broken.

#### STEP 2: Inspect Area and Chock Wheels

- Make sure area around the vehicle is clear.
- Be sure trailer wheels are chocked or spring brakes are on.
- Check that cargo (if any) is secured against movement due to tractor being coupled to the trailer.

#### STEP 3: Position Tractor

- Put the tractor directly in front of the trailer. (Never back under the trailer at an angle because you might push the trailer sideways and break the landing gear.)
- Check position, using outside mirrors, by looking down both sides of the trailer.

#### STEP 4: Back Slowly

- Back until fifth wheel just touches the trailer.
- Do not hit the trailer.

#### STEP 5: Secure Tractor

- Put on the parking brake.
- Put transmission in neutral.

#### STEP 6: Check Trailer Height

- The trailer should be low enough that it is raised slightly by the tractor when the tractor is backed under it. Raise or lower the trailer as needed. (If the trailer is too low, the tractor may strike and damage the nose of the trailer; if the trailer is too high, it may not couple correctly.)
- Check that the kingpin and fifth wheel are aligned.

#### STEP 7: Connect Air Lines to Trailer

- Check glad hand seals and connect tractor emergency air line to trailer emergency glad hand.
- Check glad hand seals and connect tractor service air line to trailer service glad hand.
- Make sure air lines are safely supported where they will not be crushed or caught while tractor is backing under the trailer.

#### STEP 8: Supply Air to Trailer

- From the cab, push in “air supply” knob or move tractor protection valve control from the “emergency” to the “normal” position to supply air to the trailer brake system.
- Wait until the air pressure is normal.
- Check brake system for crossed air lines.
  - Shut off engine so you can hear the brakes.
  - Apply and release trailer brakes and listen for sound of trailer brakes being applied and released. You should hear the brakes move when applied and air escape when the brakes are released.
  - Check air brake system pressure gauge for signs of major air loss.
- When you are sure trailer brakes are working, start engine.
- Make sure air pressure is up to normal.

**STEP 9: Lock Trailer Brakes**

- Pull out “air supply” knob or move tractor protection valve control from “normal” to “emergency.”

**STEP 10: Back Under Trailer**

- Use lowest reverse gear.
- Back tractor slowly under trailer to avoid hitting the kingpin too hard.
- Stop when the kingpin is locked into the fifth wheel.

**STEP 11: Check Connection for Security**

- Raise trailer landing gear slightly off ground.
- Pull tractor gently forward while trailer brakes are still locked to check that the trailer is locked onto the tractor.

**STEP 12: Secure Vehicle**

- Put transmission in neutral.
- Put parking brakes on.
- Shut off engine and take key with you so someone else will not move truck while you are under it.

**STEP 13: Inspect Coupling**

- Use a flashlight if necessary.
- Make sure there is no space between upper and lower fifth wheel. If there is space, something is wrong (kingpin may be on top of closed fifth wheel jaws; trailer would come loose very easily).
- Go under trailer and look into the back of the fifth wheel. Make sure the fifth wheel jaws have closed around the shank of the kingpin (see Figure 6-6 below).
- Check that locking lever is in the “lock” position.
- Check that safety latch is in position over locking lever. (On some fifth wheels, the latch must be put in place by hand.)
- If the coupling is not right, do not drive the coupled unit; get it repaired.

**Figure 6-6**  
**Trailer Kingpin**

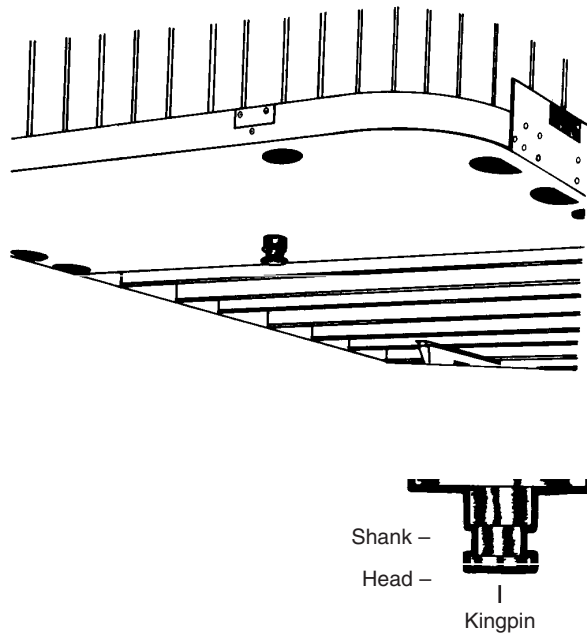

**STEP 14: Connect the Electrical Cord and Check Air Lines**

- Plug the electrical cord into the trailer and fasten the safety latch.
- Check both air lines and electrical line for signs of damage.
- Make sure air and electrical lines will not hit any moving parts of vehicle.

**STEP 15: Raise Front Trailer Supports (Landing Gear)**

- Use low gear range (if so equipped) to begin raising landing gear. Once free of weight, switch to the high gear range.
- Raise landing gear all the way up. (Never drive with landing gear only part way up, as it may catch on railroad tracks or other things.)
- After raising landing gear, secure crank handle safely.
- When full weight of trailer is resting on tractor:
  - Check for enough clearance between rear of tractor frame and landing gear. (When the tractor turns sharply, it must not hit landing gear.)
  - Check that there is enough clearance between the top of the tractor tires and the nose of the trailer.

**STEP 16: Remove Trailer Wheel Chocks**

- Remove and store wheel chocks in a safe place.

**Uncoupling Tractor-Semitrailers** — The following steps will help you to uncouple safely.

**STEP 1: Position Rig**

- Make sure surface of parking area can support weight of trailer.
- Have tractor lined up with the trailer. (Pulling out at an angle can damage landing gear.)

**STEP 2: Ease Pressure on Locking Jaws**

- Shut off trailer air supply to lock trailer brakes.
- Ease pressure on fifth wheel locking jaws by backing up gently. (This will help you release the fifth wheel locking lever.)
- Put on parking brakes while tractor is pushing against the kingpin. (This will hold rig with pressure off the locking jaws.)

**STEP 3: Chock Trailer Wheels**

- Chock the trailer wheels if the trailer does not have spring brakes or if you are not sure. (The air could leak out of the trailer air tank, releasing its emergency brakes. Without chocks, the trailer could move.)

**STEP 4: Lower the Landing Gear**

- If trailer is empty, lower the landing gear until it makes firm contact with the ground.
- If trailer is loaded, after the landing gear makes firm contact with the ground, turn crank in low gear a few extra turns. This will lift some weight off the tractor. (Do not lift trailer off the fifth wheel.) This will make it easier to unlatch the fifth wheel and easier to couple next time.

**STEP 5: Disconnect Air Lines and Electrical Cable**

- Disconnect air lines from trailer. Connect air line glad hands to dummy couplers at back of cab or couple them together.
- Hang electrical cable with plug down to prevent moisture from entering it.
- Make sure lines are supported so they will not be damaged while driving the tractor.

**STEP 6: Unlock Fifth Wheel**

- Raise release handle lock.
- Pull the release handle to “open” position.
- Keep legs and feet clear of the rear tractor wheels to avoid serious injury in case the vehicle moves.

**STEP 7: Pull Tractor Partially Clear of Trailer**

- Pull tractor forward until fifth wheel comes out from under the trailer.
- Stop with tractor frame under trailer (prevents trailer from falling to ground if landing gear should collapse or sink).

**STEP 8: Secure Tractor**

- Apply parking brake.
- Place transmission in neutral.

**STEP 9: Inspect Trailer Supports**

- Make sure ground is supporting trailer.
- Make sure landing gear is not damaged.

**STEP 10: Pull Tractor Clear of Trailer**

- Release parking brakes.
- Check the area and drive tractor forward until it clears.

## Test Your Knowledge

1. What might happen if the trailer is too high when you try to couple?
2. After coupling, how much space should be between the upper and lower fifth wheel?
3. You should look into the back of the fifth wheel to see if it is locked onto the kingpin. True or False?
4. To drive you need to raise the landing gear only until it just lifts off the pavement. True or False?

**These questions may be on the written exam.  
If you cannot answer all of them, study Section 6.3.**

## 6.4 Inspecting a Combination Vehicle

Use the 7-Step Inspection Method described in Section 2 to inspect your combination vehicle. There are more things to inspect on a combination vehicle than on a single vehicle, which are discussed below.

**Walkaround Inspection** — Perform the following checks in addition to those listed in Section 2: Step 5: Do Walkaround Inspection.

### Coupling system areas:

- Check fifth wheel (lower)
- Securely mounted to frame
  - No missing, damaged parts
  - Enough grease
  - No visible space between upper and lower fifth wheel
  - Locking jaws around the shank, **not** the head of kingpin
  - Release arm properly seated and safety latch/lock engaged
- Fifth wheel (upper)
  - Glide plate securely mounted to trailer frame
  - Kingpin not damaged
- Air and electric lines to trailer
  - Electrical cord firmly plugged in and secured
  - Air lines properly connected to glad hands, no air leaks, properly secured with enough slack for turns
  - All lines free from damage
- Sliding fifth wheel
  - Slide not damaged or parts missing
  - Properly greased
  - All locking pins present and locked in place
  - If air powered, no air leaks
  - Check that fifth wheel is not so far forward that tractor frame will hit landing gear or cab will hit the trailer during turns

### Landing gear:

- Fully raised, no missing parts, not bent or otherwise damaged
- Crank handle in place and secured
- If power operated, no air or hydraulic leaks

Perform these checks **in addition** to those in Section 5.3: Inspecting Air Brake Systems.

**Combination Vehicle Brake Check** — The following section explains how to check air brakes on combination vehicles. Check the brakes on a double or triple trailer as you would any combination vehicle.

- **Check that air flows to all trailers** – Use the tractor parking brake and/or chock the wheels to hold the vehicle. Wait for air pressure to reach normal, then push in the red “trailer air supply” knob. This will supply air to the emergency (supply) lines. Use the trailer hand brake to provide air to the service line. Go to the rear of the rig. Open the emergency line shut-off valve at the rear of the last trailer. You should hear air escaping, showing the entire



system is charged. Close the emergency line valve. Open the service line valve to check that service pressure goes through all the trailers (this test assumes that the trailer hand brake or the service brake pedal is on), then close the valve. If you do NOT hear air escaping from both lines, check that the shut-off valves on the other trailer(s) and dolly(s) are in the OPEN position. You MUST have air all the way to the back for all the brakes to work.

- **Test tractor protection valve** – Charge the trailer air brake system. (i.e., build up normal air pressure and push the “air supply” knob in.) Shut off the engine. Step on and off the brake pedal several times to reduce the air pressure in the tanks. The trailer air supply control (also called the tractor protection valve control) should pop out or go from “normal” to “emergency” position) when the air pressure falls into the pressure range specified by the manufacturer (usually within the range of 20 to 45 psi).

If the tractor protection valve does not work correctly, an air hose or trailer brake leak could drain all the air from the tractor. This would cause the emergency brakes to come on, with possible loss of control.

- **Test trailer emergency brakes** – Charge the trailer air brake system and check that the trailer rolls freely. Then stop and pull out the trailer air supply control (also called “tractor protection valve control” or “trailer emergency valve”) or place it in the “emergency” position. Pull gently on the trailer with the tractor to check that the trailer emergency brakes are on.
- **Test trailer service brakes** – Check for normal air pressure, release the parking brakes, move the vehicle forward slowly, and apply trailer brakes with the hand control (trolley valve), if so equipped. You should feel the brakes come on. This tells you the trailer brakes are connected and working. (The trailer brakes should be tested with the hand valve but controlled in normal operation with the foot pedal, which applies air to the service brakes at all wheels.)

### Test Your Knowledge

1. Which shut-off valves should be open and which ones should be closed?
2. How can you test that air flows to all trailers?
3. How can you test the tractor protection valve?
4. How can you test the trailer emergency brakes?
5. How can you test the trailer service brakes?
6. What is the minimum tread depth for front tires?

**These questions may be on the written exam.  
If you cannot answer all of them, study Section 6.4**

# Section 7: Double/Triple Trailers

## 7.1 Pulling Double/Triple Trailers

This section has information needed to pass the CDL knowledge exam for driving safely with double and triple trailers. (You also should study Sections 2, 5 and 6.)

Take special care when pulling two and three trailers. There are more things that can go wrong, and doubles/triples are less stable than other commercial vehicles. Some areas of concern are discussed below.

**Prevent Trailers From Rolling Over** — To prevent trailers from rolling over, you must steer gently and go slowly around corners, on ramps, off ramps and curves. A safe speed on a curve for a straight truck or a single trailer combination vehicle may be too fast for a set of doubles or triples.

**Crack-the-Whip Effect** — Doubles and triples are more likely to turn over than other combination vehicles because of the “crack-the-whip” effect. You must steer gently when pulling trailers. The last trailer in a combination is most likely to turn over. If you do not understand the crack-the-whip effect, study Section 6.1 and review Figure 6-1 on page 70.

**Inspect Completely** — There are more critical parts to check when you have two or three trailers. Check all of them by following the procedures described later in this section.

**Look Far Ahead** — Doubles and triples must be driven very smoothly to avoid rollover or jackknife. Therefore, look far ahead so you can slow down or change lanes gradually when necessary.

**Manage Space** — Doubles and triples take up more space than other commercial vehicles. They are not only longer, but also need more space because they cannot be turned or stopped suddenly. Allow more following distance. Make sure you have large enough gaps before entering or crossing traffic. Be sure you are clear at the sides before changing lanes.

**Adverse Conditions** — Be more careful in adverse conditions. In bad weather, slippery conditions and mountain driving, you must be especially careful if you drive double and triple bottoms. You will have greater length and more dead axles to pull with your drive axles than other drivers. There is more chance for skids and loss of traction.

## 7.2 Coupling and Uncoupling

Knowing how to couple and uncouple correctly is basic to the safe operation of doubles and triples. Wrong coupling and uncoupling can be very dangerous. Coupling and uncoupling steps for doubles and triples are outlined below.

### Coupling Twin Trailers —

**Secure second (rear) trailer:** If the second trailer does not have spring brakes, drive the tractor close to the trailer, connect the emergency line, charge the trailer air tank, and disconnect the emergency line. This will set the trailer emergency brakes (if the slack adjusters are correctly adjusted). Chock the wheels if you have any doubt about the brakes.

**Couple tractor and first semitrailer as described earlier:** A converter gear or dolly is a coupling device of one or two axles and a fifth wheel by which a semitrailer can be coupled to the rear of a tractor-trailer combination forming a double bottom rig.

**Caution:** For the safest handling on the road, the more heavily loaded semi-trailer should be in first position behind the tractor. The lighter trailer should be in the rear.

### Position converter dolly in front of second (rear) trailer:

- Release dolly brakes by opening the air tank petcock. (Or, if the dolly has spring brakes, use the dolly parking brake control.)
- If the distance is not too great, wheel dolly into position by hand so it is in line with the kingpin.
- Or, use the tractor and first semitrailer to pick up the converter dolly:
  - Position combination as close as possible to converter dolly.

- Move dolly to rear of first semi-trailer and couple it to the trailer.
- Lock pintle hook.
- Secure dolly support in raised position.
- Pull dolly into position as close as possible to nose of the second semitrailer.
- Lower dolly support.
- Unhook dolly from first trailer.
- Wheel dolly into position in front of second trailer in line with the kingpin.

**Connect converter dolly to front trailer:**

- Back first semi-trailer into position in front of dolly tongue.
- Hook dolly to front trailer.
  - Lock pintle hook.
  - Secure converter gear support in raised position.

**Connect converter dolly to rear trailer:**

- Make sure trailer brakes are locked and/or wheels chocked.
- Make sure trailer height is correct. (It must be slightly lower than the center of the fifth wheel, so trailer is raised slightly when dolly is pushed under.)
- Back converter dolly under rear trailer.
- Raise landing gear slightly off ground to prevent damage if trailer moves.
- Test coupling by pulling against pin of number two semi-trailer.
- Make visual check of coupling. (No space between upper and lower fifth wheel. Locking jaws closed on kingpin.)
- Connect safety chains, air hoses and light cords.
- Close converter dolly air tank petcock and shut-off valves at rear of second trailer (service and emergency shut-offs).
- Open shut-off valves at rear of first trailer (and on dolly if so equipped).
- Raise landing gear completely.
- Charge trailers (push “air supply” knob in) and check for air at rear of second trailer by opening the emergency line shut-off. If air pressure is not there, something is wrong and the brakes will not work.

**Uncoupling Twin Trailers —**

**Uncouple rear trailer:**

- Park in a straight line on firm level ground.
- Apply parking brakes so rig will not move.
- Chock wheels of second trailer if it does not have spring brakes.
- Lower landing gear of second semitrailer enough to remove some weight from dolly.
- Close air shut-offs at rear of first semitrailer (and on dolly if so equipped).
- Disconnect all dolly air and electric lines and secure them.
- Release dolly brakes.
- Release converter dolly fifth wheel latch.
- Slowly pull tractor, first semi-trailer and dolly forward to pull dolly out from under rear semi-trailer.

**Uncouple converter dolly:**

- Lower dolly landing gear
- Disconnect safety chains.
- Apply converter gear spring brakes or chock wheels.
- Release pintle hook on first semitrailer.
- Slowly pull clear of dolly.

**Caution:** Never unlock the pintle hook with the dolly still under the rear trailer. The dolly tow bar may fly up, possibly causing injury and making it very difficult to re-couple.

**Coupling and Uncoupling Triple Trailers —**

**Couple second and third trailers:**

- Couple second and third trailers using the method for coupling doubles.
- Uncouple tractor and pull away from second and third trailers.

**Couple tractor/first semitrailer to second/third trailers:**

- Couple tractor to first trailer. Use the method described for coupling tractor semitrailers.
- Move converter dolly into position and couple first trailer to second trailer using the method for coupling doubles. Triples rig is now complete.

**Uncouple triple-trailer rig:**

- Uncouple third trailer by pulling the dolly out, then unhitching the dolly using the method for uncoupling doubles.
- Uncouple remainder of rig as you would any double-bottom rig using the method already described.

**Coupling and Uncoupling Other Combinations** — The methods described thus far apply to the more common tractor-trailer combinations. However, there are other ways of coupling and uncoupling the many types of truck-trailer and tractor-trailer combinations in use. There are too many to cover in this manual. Learn the correct way to couple the vehicle(s) you will drive according to the manufacturer and/or owner.

### 7.3 Inspecting Doubles and Triples

Use the 7-Step Inspection Method described in Section 2 to inspect your combination vehicle. There are additional things to inspect on a combination vehicle than on a single vehicle. Perform the following checks in addition to those listed in Section 2: Step 5: Do Walkaround Inspection.

**Coupling system areas:**

- Check fifth wheel (lower)
  - Securely mounted to frame
  - No missing, damaged parts
  - Enough grease
  - No visible space between upper and lower fifth wheel
  - Locking jaws around shank, not head of kingpin
  - Release arm properly seated and safety latch/lock engaged
- Fifth wheel (upper)
  - Glide plate securely mounted to trailer frame
  - Kingpin not damaged
- Air and electric lines to trailer
  - Electrical cord firmly plugged in and secured
  - Air lines properly connected to glad hands; no air leaks; properly secured with enough slack for turns
  - All lines free of damage
- Sliding fifth wheel
  - Slide not damaged or parts missing
  - Properly greased
  - All locking pins present and locked in place
  - If air powered — no air leaks
  - Fifth wheel is not so far forward that tractor frame will hit landing gear or cab will hit the trailer during turns

**Landing gear:**

- Fully raised, no missing parts, not bent or otherwise damaged
- Crank handle in place and secured
- If power operated, no air or hydraulic leaks

**Double and triple trailers:**

- Shut-off valves (at rear of trailers, in service and emergency lines)
  - Rear of front trailers: OPEN
  - Rear of last trailer: CLOSED
  - Converter dolly air tank drain valve: CLOSED
- Air lines supported and glad hands properly connected
- If spare tire is on converter gear (dolly), make sure it is secured
- Pintle-eye of dolly in place in pintle hook of trailer(s)
- Pintle hook latched
- Safety chains secured to trailer(s)
- Light cords firmly in sockets on trailers

## 7.4 Doubles/Triples Air Brake Check

Perform the following checks **in addition** to Section 5.3: Inspecting Air Brake Systems.

Check the brakes on a double or triple trailer as you would any combination vehicle. Section 6.2 explains how to check air brakes on combination vehicles. You also must make the following checks on your double or triple trailers:

**Check air flow to all trailers:** Use the tractor parking brake and or chock the wheels to hold the vehicle. Wait for air pressure to reach normal, then push in the red “trailer air supply” knob. This will supply air to the emergency (supply) lines. Use the trailer handbrake to provide air to the service line. Go to the rear of the rig. Open the emergency line shut-off valve at the rear of the last trailer. You should hear air escaping, showing the entire system is charged. Close the emergency line valve. Open the service line valve to check that service pressure goes through all the trailers (this test assumes that the trailer handbrake or the service brake pedal is on), then close the valve. If you do NOT hear air escaping from both lines, check that the shut-off valves on the trailer(s) and dolly (5) are in the OPEN position. You MUST have air all the way to the back for all the brakes to work.

**Test tractor protection valve:** Charge the trailer air brake system, (i.e., build up normal air pressure and push the “air supply” knob in). Shut the engine off. Step on and off the brake pedal several times to reduce the air pressure in the tanks. The trailer air supply control (also called the tractor protection valve control) should pop out (or go from “normal” to “emergency” position) when the air pressure falls into the pressure range specified by the manufacturer (usually within the range of 20 to 45 psi).

**Test trailer emergency brakes:** If the tractor protection valve does not work correctly, an air hose or trailer brake leak could drain all the air from the tractor. This would cause the emergency brakes to come on, with possible loss of control.

**Test trailer service brakes:** Charge the trailer air brake system and check that the trailer rolls freely. Then stop and pull out the trailer air supply control (also called tractor protection valve control or trailer emergency valve) or place it in the “emergency” position. Pull gently on the trailer with the tractor to check that the trailer emergency brakes are on.

Check for normal air pressure, release the parking brakes, move the vehicle forward slowly, and apply trailer brakes with the hand control (trolley valve), if so equipped. You should feel the brakes come on. This tells you the trailer brakes are connected and working. (The trailer brakes should be tested with the hand valve, but controlled in normal operation with the foot pedal, which applies air to the service brakes at all wheels.)

### Test Your Knowledge

1. What is a converter dolly?
2. Do converter dollies have spring brakes?
3. What three methods can you use to secure a second trailer before coupling?
4. How do you check to make sure trailer height is correct before coupling?
5. What do you check when making a visual check of coupling?
6. Why should you pull a dolly out from under a trailer before you disconnect it from the trailer in front?
7. What should you check for when inspecting the converter dolly? The pintle hook?
8. Should the shut-off valves on the rear of the last trailer be open or closed? On the first trailer in a set of doubles? On the middle trailer of a set of triples?
9. How can you test that air flows to all trailers?

**These questions may be on the written exam.**

**If you cannot answer all of them, study Sections 7.1 through 7.4.**

# Section 8: Tank Vehicles

This section has information needed to pass the CDL knowledge exam for driving a tank vehicle. (You should also study Sections 2, 5, and 6.) A “tank vehicle” is used to carry any liquid or gaseous material in a tank that is permanently or temporarily attached to the vehicle or chassis. However, this does not include portable tanks with a rated capacity of less than 1,000 gallons.

Before loading, unloading or driving a tanker, inspect the vehicle. This ensures that the vehicle is safe to carry the liquid or gas and is safe to drive.

## 8.1 Inspecting Doubles and Triples

Tank vehicles have special items that you need to check. Tank vehicles come in many types and sizes. Check the vehicle’s operator’s manual to make sure you know how to inspect your tank vehicle.

**Vehicles must be purged of hazardous materials 48 hours prior to testing with documentation verifying the purge.**

On all tank vehicles, the most important item to check for is leaks. Check under and around the vehicle for signs of any leaking. Do not carry liquids or gases in a leaking tank. In general, check the following:

- Tank body or shell for dents or leaks.
- Intake, discharge and cut-off valves. Make sure valves are in correct position before loading, unloading or moving the vehicle.
- Pipes, connections and hoses for leaks, especially around joints.
- Manhole covers and vents. Make sure covers have gaskets and that they close correctly. Keep vents clear so they work correctly.
- Special purpose equipment. If your vehicle has any of the following equipment, make sure it works:
  - Vapor recovery kits.
  - Grounding and bonding cables.
  - Emergency shut-off systems.
  - Built-in fire extinguisher.

Make sure you know how to operate your special equipment. Check the emergency equipment required for your vehicle. Find out what equipment you are required to carry and make sure you have it (and it works).

## 8.2 Driving Tank Vehicles

**High Center of Gravity** — Hauling liquids in tanks requires special skills because of the high center of gravity and liquid movement. A high center of gravity means that much of the load’s weight is carried high up off the road. This makes the vehicle top-heavy and easy to roll over. Liquid tankers are especially easy to roll over. Tests show that tankers can turn over at the speed limits posted for curves. Take highway curves and on-ramp/off-ramp curves well below the posted speed limits.

**Liquid Surge** — Liquid surge results from movement of the liquid in partially filled tanks. This movement can have bad effects on handling. For example, when coming to a stop, the liquid will surge back and forth. When the wave hits the end of the tank, it tends to push the truck in the direction the wave is moving. If the truck is on a slippery surface such as ice, the wave can shove a stopped truck out into an intersection. The driver of a liquid tanker must be very familiar with the handling of the vehicle.

**Bulkheads:** Some liquid tanks are divided into several smaller tanks by bulkheads. When loading and unloading the smaller tanks, the driver must pay attention to weight distribution. Do not put too much weight on the front or rear of the vehicle.

**Baffled tanks:** Baffled liquid tanks have bulkheads in them with holes that let the liquid flow through. The baffles help to control the forward and backward liquid surge. Side-to-side surge can still occur. This can cause a roll over.

**Unbaffled tanks:** Unbaffled liquid tankers (sometimes called “smooth bore” tanks) have nothing inside to slow down the flow of the liquid. Therefore, forward-and-back surge is very strong. Unbaffled tanks are usually those that transport food products (e.g., milk). (Sanitation regulations forbid the use of baffles because of the difficulty in cleaning the inside of the tank.) Be extremely cautious (slow and careful) in driving smooth bore tanks, especially when starting and stopping.

**How Much to Load** — Never load a cargo tank totally full. Liquids expand as they warm and you must leave room for the expanding liquid. This is called “outage.” Since different liquids expand by different amounts, they require different amounts of outage. You must know the outage requirement when hauling liquids in bulk.

A full tank of dense liquid (such as some acids) may exceed legal weight limits. For that reason, you often may only partially fill tanks with heavy liquids. The amount of liquid to load into a tank depends on:

- The amount the liquid will expand in transit.
- The weight of the liquid.
- Legal weight limits.

### 8.3 Safe Driving Rules

To drive tank vehicles safely, you must follow all safe driving rules:

- **Drive smoothly** – Because of the high center of gravity and the surge of the liquid, you must start, slow down and stop very smoothly. Also, make smooth turns and lane changes.
- **Braking** – If you must make a quick stop to avoid an accident, use controlled or stab braking. If you do not remember how to stop using these methods, review Section 2.13. Also, remember that if you steer quickly while braking, your vehicle may roll over.
- **Curves** – Slow down before curves, then accelerate slightly through the curve. The posted speed for a curve may be too fast for a tank vehicle.
- **Stopping distance** – Keep in mind how much space you need to stop your vehicle. Remember that wet roads double the normal stopping distance. Empty tank vehicles may take longer to stop than full ones.
- **Skids** – Do not over steer, over accelerate or over brake. If you do, your vehicle may skid. On tank trailers, if your drive wheels or trailer wheels begin to skid, your vehicle may jackknife. When any vehicle starts to skid, you must take action to restore traction to the wheels.

#### Test Your Knowledge

1. How are bulkheads different than baffles?
2. Should a tank vehicle take curves, on-ramps, or off-ramps at the posted speed limits?
3. How are smooth bore tankers different to drive than those with baffles?
4. What three things determine how much liquid you can load?
5. What is outage?
6. What is the minimum tread depth for front tires?
7. For other tires?

**These questions may be on the written exam.  
If you cannot answer all of them, study Section 8.2.**

## Section 9: Hazardous Materials

The hazardous material transportation information in this section reflects all revisions as of October 2007. This section contains partial information relative to the hazardous material requirements. The purpose of this section is to prepare an individual for the CDL hazardous material test. It should not be used for the hazardous material recurrent training. For detailed hazardous material transportation information, consult the regulations or IDOT at 217-785-1181.

Prior to seeking the Hazardous Materials Endorsement, you must complete the application for the fingerprint and security background checks. Call 877-429-7746 or visit [www.hazprints.com](http://www.hazprints.com) to complete the application process and make an appointment at a convenient location. The fee must be paid at the time of application.

**Types of Hazardous Materials** — Hazardous materials are products that pose a risk to health, safety and property during transportation. The term often is shortened to HAZMAT, which you may see on road signs, or HM in government regulations. Hazardous materials include explosives, various types of gas, solids, flammable and combustible liquid, and other materials. Because of the risks involved and the potential consequences these risks impose, the handling of hazardous material is very heavily regulated by all levels of government.

The Hazardous Materials Regulations (HMR) are found in parts 171-180 of title 49 of the Code of Federal Regulations. The common reference for these regulations is 49 CFR 171-180.

The Hazardous Materials Table in these regulations contains a list of these items. However, this list is not all-inclusive. Whether or not a material is considered hazardous is based on its characteristics and the shipper's decision on whether or not the material meets a definition of a hazardous material in the regulations.

The regulations require vehicles transporting certain types or quantities of hazardous materials to display diamond-shaped, square-on-point, warning signs called placards.

This section is designed to assist you in understanding your role and responsibilities in hauling hazardous materials. Due to the constantly changing nature of government regulations, it is impossible to guarantee absolute accuracy of the materials in this section. An up-to-date copy of the complete regulations, which includes a complete glossary of terms, is essential for you to have.

**Hazardous Materials Endorsement** — You must have a CDL with a Hazardous Materials Endorsement before driving vehicles carrying hazardous materials that require placards. You must pass a written exam about the regulations and requirements to get this endorsement.

**Training and Testing** — Everything you need to know to pass a security background check and the written exam is in this section. However, this is only a beginning. Most drivers need to know much more on the job. You can learn more by reading and understanding the federal and state rules applicable to hazardous materials as well as attending hazardous materials training courses. These courses are usually offered by your employer, colleges and universities, and various associations. You may obtain copies of the Federal Regulations (49 CFR) from your local Government Printing Office bookstore and various industry publishers. Union or company offices often have copies of the rules for driver use.

The regulations require training and testing for all drivers involved in transporting hazardous materials. Your employer or a designated representative is required to provide this training and testing. Hazardous materials employers are required to keep a record of that training on each employee as long as that employee is working with hazardous materials, and for 90 days thereafter. The regulations require that hazardous materials employees be trained and tested at least once every three years.

The regulations also require that drivers have special training before driving a vehicle transporting certain flammable gas materials or highway route controlled quantities of radioactive materials. In addition, drivers transporting cargo tanks and portable tanks must receive specialized training. Each driver's employer or designated representative must provide such training.

**Permits** — Some locations require permits to transport certain explosives or bulk hazardous wastes. States and counties also may require drivers to follow special hazardous materials routes. The federal government may require permits or exemptions for special hazardous materials cargo such as rocket fuel. Find out about permits, exemptions and special routes for places you drive.



## 9.1 Intent of Regulations

Transporting hazardous materials can be risky. The regulations are intended to protect you, those around you, and the environment. They tell shippers how to package the materials safely and drivers how to load, transport and unload the materials. These are called “containment rules.”

To communicate the risk, shippers must warn drivers and others about materials hazards. The regulations require shippers to put hazard warning labels on packages, provide proper shipping papers, emergency response information and placards. These steps communicate the hazard to the shipper, the carrier and the driver.

To obtain a Hazardous Materials Endorsement on a CDL, you must initially and at each renewal pass a written exam about transporting hazardous materials. To pass the exam, you must know how to:

- Identify hazardous materials.
- Safely load shipments.
- Properly placard your vehicle in accordance with the rules.
- Safely transport shipments.

Learn the rules and follow them. Following the rules reduces the risk of injury from hazardous materials. Taking shortcuts by breaking rules is unsafe and against the law.

Inspect your vehicle before and during each trip. Law enforcement officers may stop and inspect your vehicle. When stopped, they may check your shipping papers, vehicle placards, the hazardous materials endorsement on your driver’s license, and your knowledge of hazardous materials.

## 9.2 Hazardous Materials Transportation

### The shipper:

- Sends products from one place to another by truck, rail, vessel or airplane.
- Uses the hazardous materials regulations to decide the product’s:
  - Proper shipping name
  - Hazard class
  - Identification number
  - Correct packaging
  - Correct label and markings
  - Correct placards
- Must package, mark and label the materials, prepare shipping papers, provide emergency response information and supply placards.
- Certify on the shipping paper that the shipment has been prepared according to the rules (unless you are pulling cargo tanks supplied by you or your employer).

### The carrier:

- Takes the shipment from the shipper to its destination.
- Prior to transportation, checks that the shipper correctly described, marked, labeled and otherwise prepared the shipment for transportation.
- Refuses improper shipments.
- Reports accidents and incidents involving hazardous materials to the proper government agency.

### The driver:

- Makes sure the shipper has identified, marked and labeled the hazardous materials properly.
- Refuses leaking packages and shipments.
- Placards his vehicle when loading, if required.
- Safely transports the shipment without delay.
- Follows all special rules about transporting hazardous materials.
- Keeps hazardous materials shipping papers and emergency response information in the proper place.

## 9.3 Communication Rules

Some words and phrases have special meanings when talking about hazardous materials. Some of these may differ from meanings you are used to. The words and phrases in this section may be on your exam. The meanings of other important words are in the glossary at the end of Section 9.

**Hazard Class** — A material's **hazard class** reflects the risks associated with it. The hazard class of a hazardous material is indicated by its class (or division) number, its class name, or by the letters "ORM-D." Figure 9-1 below lists class numbers, division numbers, class or division names and those sections of this subchapter that contain definitions for classifying hazardous materials, including forbidden materials.

**Figure 9-1  
Hazardous Materials Hazard  
Class/Division Table**

Class No.	Division No. (if any)	Name of Class or Division
None		Forbidden materials
None		Forbidden explosives
1	1.1	Explosives (with a mass explosion hazard)
1	1.2	Explosives (with a projection hazard)
1	1.3	Explosives (with predominantly a fire hazard)
1	1.4	Explosives (with no significant blast hazard)
1	1.5	Very insensitive explosives; blasting agents
1	1.6	Extremely insensitive detonating substances
2	2.1	Flammable gas
2	2.2	Non-flammable compressed gas
2	2.3	Poisonous gas
3		Flammable and combustible liquid
4	4.1	Flammable solid
4	4.2	Spontaneously combustible material
4	4.3	Dangerous when wet material
5	5.1	Oxidizer
5	5.2	Organic peroxide
6	6.1	Poisonous materials
6	6.2	Infectious substance (Etiologic agent)
7		Radioactive material
8		Corrosive material
9		Miscellaneous hazardous material
None		Other regulated material: ORM-D

**Shipping Papers** — Shipping papers describe the hazardous materials being transported. Shipping orders, bills of lading and manifests are all considered shipping papers. Figure 9-6 on page 92 shows an example of a shipping paper.

After an accident or hazardous materials spill or leak, you may be injured and unable to communicate the hazards of the materials you are transporting. Firefighters and police can prevent or reduce the amount of damage or injury at the scene if they know what hazardous materials are being carried. Your life, and the lives of others, may depend on quickly locating the hazardous materials shipping papers. For that reason, the rules require:

- Shippers to describe hazardous materials correctly and include an emergency response telephone number on shipping papers.
- Carriers and drivers to put tabs on hazardous materials shipping papers, or keep them on top of other shipping papers and keep the required emergency response information with the shipping papers.
- Drivers to keep hazardous materials shipping papers:
  - In a pouch on the driver's door, or
  - In clear view within immediate reach while the seat belt is fastened while driving, or
  - On the driver's seat when out of the vehicle.

**Package Labels** — Shippers put diamond-shaped hazard warning labels on most hazardous materials packages (see Figure 9-2 on page 89). These labels inform others of the hazard. If the diamond label will not fit on the package, shippers may put the label on a tag securely attached to the package. For example, compressed gas cylinders that will not hold a label will have tags or decals.

**Figure 9-2**  
**Package Label Examples**

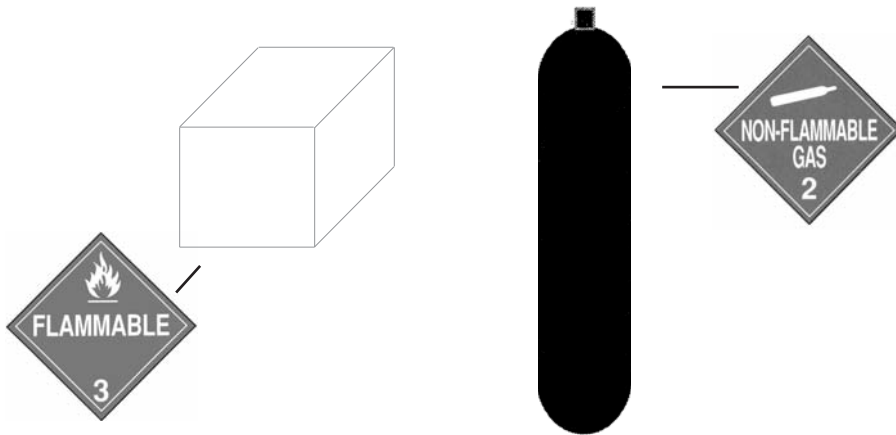

**Placards** — Placards are used to warn others of hazardous materials. Placards are signs put on the outside of a vehicle that identify the hazard class of the cargo. A placarded vehicle must have at least four identical placards. They are put on the front, rear and both sides of the vehicle (see Figure 9-3 below). Placards must be readable from all four directions. They are 10 3/4-inches square, square-on-point, in a diamond shape. Cargo tanks and other bulk packaging display the ID number of their contents on placards or orange panels or white square-on-point displays that are the same size as placards.

Hazardous material identification numbers may be displayed on white square on point or orange panels meeting specifications in 49CFR 172.332(b) and 172.336(b).

**Figure 9-3**  
**Placard and Panel Locations**

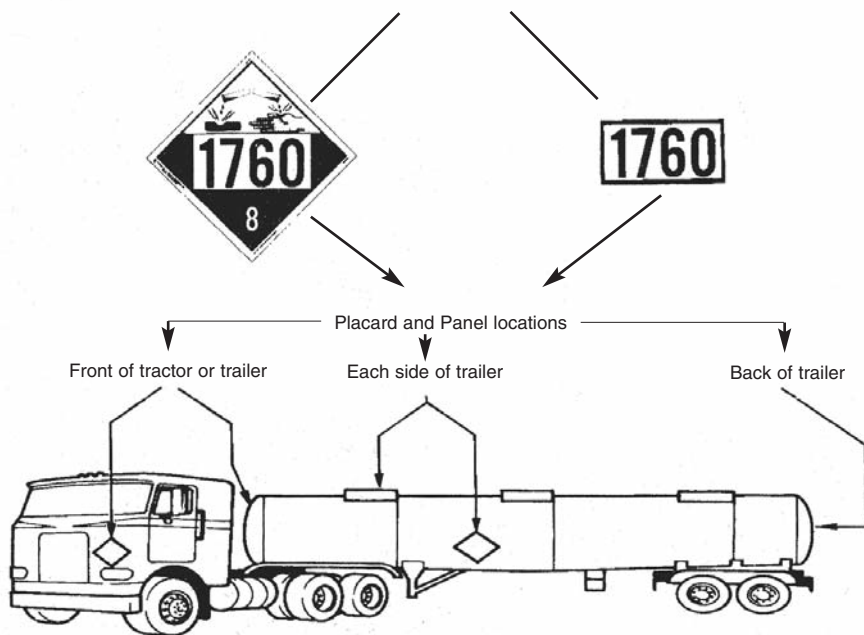

**Lists of Regulated Products** — There are three main lists used by shippers, carriers and drivers when identifying hazardous materials. Before transporting a material, look for its name on three lists. Some materials are on all lists, others on only one. Always check the following lists:

- Section 172.101: Hazardous Materials Table
- Appendix A to Section 172.101: List of Hazardous Substances and Reportable Quantities
- Appendix B to Section 172.101: List of Marine Pollutants

**Hazardous Materials Table:** Figure 9-4 shows part of the Hazardous Materials Table. Column 1 tells which shipping mode(s) the entry affects and other information concerning the shipping description. The next five columns show each material's shipping name, hazard class, ID number, packing group and required labels.

**Figure 9-4  
Part of Hazardous  
Materials Table**

§ 172.101 Hazardous Materials Table									
Symbols (1)	Hazardous Materials Descriptions and Proper Shipping Names (2)	Hazard Class or Division (3)	Identifi- cation Numbers (4)	PG (5)	Label Codes (6)	Special Provisions (7)	(8) Packaging Authorizations (\$ 173.***)		
							(8A)	(8B)	(8c)
+	Toxic solids, self heating, n.o.s....	6.1	UN3124	I & II	6.1, 4.2	A5, B100	None	211	242

**Column 1** – Six different symbols may appear in Column 1:

- (+) Fixes the proper shipping name, hazard class and packing group to use, even if the material does not meet the hazard class definition.
- (A) Means the hazardous material described in Column 2 is subject to the HMR only when offered or intended for transport by air unless it is a hazardous substance or hazardous waste.
- (W) Means the hazardous material described in Column 2 is subject to the HMR only when offered or intended for transportation by water unless it is a hazardous substance, hazardous waste.
- (D) Means the proper shipping name is appropriate for describing materials for domestic transportation, but may not be proper for international transportation.
- (I) Identifies a proper shipping name that is used to describe materials in international transportation. A different shipping name may be used when only domestic transportation is involved.
- (G) Identifies the proper shipping names for which one or more technical names of the hazardous material must be entered in parentheses in association with the basic description.

**Column 2** – Lists the proper shipping names and descriptions of regulated materials. Entries are in alphabetical order so you can more quickly find the right entry. Use the name of the material from the shipping paper. The table shows proper shipping names in Roman type. The shipping paper must show proper shipping names. Names shown in italics are not proper shipping names.

**Column 3** – Shows a material's hazard class or division, or the entry "Forbidden." Never transport a "Forbidden" material. Placard shipments are based on the quantity and hazard class. You can decide which placards to use if you know these three things:

- Material's hazard class.
- Amount being shipped.
- Amount of all hazardous materials of all classes on your vehicle.

**Column 4** – Lists the identification number for each proper shipping name. Identification numbers are preceded by the letters "UN" or "NA." The letters "NA" are associated with proper shipping names used only within the United States and to and from Canada. The identification number must appear on the shipping paper as part of the shipping description and also appear on the package. It also must appear on cargo tanks and other bulk packaging. Police and firefighters use this number to quickly identify the hazardous materials.

**Column 5** – Shows the packaging group assigned to a material.

**Column 6** – Shows the hazard warning label codes shippers must use to determine the proper labels for packages of hazardous materials. Some products require more than one label due to a subsidiary hazard being present. The first label code represents the primary hazard of the material. No label is needed where the table shows the word NONE.

**Column 7** – Lists the additional (special) provisions that apply to this material. When there is an entry in this column, refer to Section 172.102 of the federal regulations for specific information.

**Column 8** – A three-part column showing the section numbers covering the exceptions, non-bulk packaging and bulk packaging requirements for each hazardous material.

**NOTE: Columns 9 and 10 do not apply to transportation by highway.**

**Appendix A to §172.101–Hazardous Substances and Reportable Quantities:** DOT and EPA need to know about any spills of **hazardous substances** named in the List of Hazardous Substances and Reportable Quantities (see Figure 9-5). Column 2 shows each product’s reportable quantity (RQ). When these materials are being transported in a reportable quantity or greater in one package, the shipper displays the letters RQ on the shipping paper and package. The letters RQ may appear before or after the basic description. You or your employer must report any spill of these materials that occurs in a reportable quantity.

Hazardous Substances and Reportable Quantities	
Hazardous Substance	Reportable Quantity (RQ) Pounds (Kilograms)
Phenyl merrcaptan @	100 (45.4)
Phenylmercuric acetate	100 (45.4)
Phenylthiourea	100 (45.4)
Phorate	10 (4.54)
Phosgene	10 (4.54)
Phosphine	10 (4.54)
Phosphoric acid	5000 (2270)
Phosphoric acid, diethyl 4-nitrophenyl ester (2+)	100 (45.4)
Phosphoric acid, lead salt (2-3)	10 (4.54)

Spills of 10 pounds or more must be reported.

**Figure 9-5  
Hazardous Substances and  
Reportable Quantities**

If the words POISON or TOXIC INHALATION HAZARD appear on the shipping paper, package or label, the rules require that the transport vehicle be placarded with a POISON INHALATION HAZARD or POISON GAS placard, as appropriate. These placards must be used in addition to other placards that may be required by the product’s hazard class. INHALATION HAZARD materials always require the appropriate placard, even for small amounts of these materials.

**Test Your Knowledge**

1. Shippers package in order to (fill in the blank) the material.
2. Drivers placard their vehicle to (fill in the blank) the risk.
3. What three things do you need to know to decide which placards (if any) you need?
4. A hazardous materials ID number must appear on the (fill in the blank) and on the (fill in the blank). The identification number also must appear on cargo tanks and other bulk packagings.
6. Where must you keep shipping papers describing hazardous materials?

**These questions may be on the written exam.  
If you cannot answer all of them, study Section 9-1 through 9-9.**

**Shipping Paper** — The shipping paper shown in Figure 9-6 below describes a shipment. A shipping paper for hazardous material must include:

- Page numbers if the shipping paper has more than one page. The first page must tell the total number of pages. (e.g., Page 1 of 4).
- A proper shipping description for each hazardous material.
- A **shipper's certification**, signed by the shipper, saying the shipment was prepared according to the rules.

**Item Description** — If a shipping paper describes both hazardous and non-hazardous products, the hazardous materials will either be:

- Described first, or
- Highlighted in a contrasting color, or
- Identified by an "X" placed before the shipping name in a column captioned "HM." The letters "RQ" may be used instead of "X" if a reportable quantity is present in one package.

The basic description of a hazardous material includes the proper shipping name, hazard class, subsidiary hazard class(es) - 172-202(a)(3), effective Oct. 1, 2007, or division, identification number and the packing group, if any, in that order. The packing group is displayed in Roman numerals and may be preceded by "PG." Subsidiary hazard classes must be entered in the basic description.

- (b) Except as provided in this subpart, the basic description specified in paragraphs (a)(1), (2), (3) and (4) of this section must be shown in sequence with no additional information interspersed. For example: "Cyclobutylchloroformate, 6.1, (8,3), UN2744, PG II." Alternatively, the basic description may be shown with the identification (ID) number listed first. For example: "UN2744, Cyclobutyl chloroformate, 6.1, (8,3), PG II."

The shipping name, hazard class and ID number must not be abbreviated unless specifically authorized in the hazardous materials regulations. The description also must show:

- The number and type of packages must be indicated.
- The letters RQ, if a reportable quantity.
- If the letters RQ appear, the name of the hazardous substance.
- For "not otherwise specified" and generic descriptions, the technical name of the hazardous material.

SHIPPING PAPER		Page 1 of 1	
TO: Wafers R Us 88 Valley Street Silicon Junction, CA		FROM: Essex Corporation 5775 Dawson Avenue Goleta, CA 93117	
QTY	HM	DESCRIPTION	WEIGHT
1cyl	RQ	Phosgene, 2.3. UN1076, Poison, Inhalation Hazard, Zone A	25 lbs.
This is to certify that the above named materials are properly classified, described, packaged, marked and labeled, and are in proper condition for transportation according to the applicable regulations of the Department of Transportation.			
Shipper:	Essex Corp	Carrier:	Knuckle Bros.
Per:	Shultz	Per:	
Date:	6/27/05	Date:	
<b>SPECIAL INSTRUCTIONS: Emergency Contact, Ed Shultz, 1-800-555-5555</b>			

**Figure 9-6**  
**Shipping Paper Example**

"RQ" means that this is a reportable quantity

Proper shipping name from Column 2 of the Hazardous Materials Table

Hazard Class from Column 3 of the Table

ID Number from Column 4 of the Hazardous Materials Table

Shipping papers also must list an emergency response telephone number. The emergency response telephone number is the responsibility of the shipper. It can be used by emergency responders to obtain information about any hazardous materials involved in a spill or fire.

Shippers also must provide emergency response information to the motor carrier for each hazardous material being shipped. The emergency response information must be able to be used away from the motor vehicle and must provide information on how to safely handle incidents involving the material. It must include information on the shipping name of the hazardous materials, risks to health, fire, explosion, and initial methods of handling spills, fires and leaks of the materials.

Such information can be on the shipping paper or some other document that includes the basic description and technical name of the hazardous material. Or, it may be in a guidance book such as the Emergency Response Guidebook (ERG). Motor carriers may assist shippers by keeping an ERG on each vehicle carrying hazardous materials. The driver must provide the emergency response information to any federal, state or local authority responding to a hazardous materials incident or investigating one.

Total quantity must appear before or after the basic description. The packaging type and the unit of measurement may be abbreviated. Example: 10 ctns. Paint, 3, UN1263, PG II, 500 lbs.

The shipper of hazardous wastes must put the word WASTE before the proper shipping name of the material on the shipping paper (hazardous waste manifest). **Example: Waste Acetone, 3, UN1090, PG II.**

A non-hazardous material **may not** be described by using a hazard class or an ID number.

**Shipper's Certification** — When the shipper packages hazardous materials, he/she certifies that the package has been prepared according to the rules. The signed shipper's certification appears on the original shipping paper. The only exceptions are when a shipper is a private carrier transporting their own product, and when the package is provided by the carrier (e.g., a cargo tank). Unless a package is clearly unsafe or does not comply with the HMR, you may accept the shipper's certification concerning proper packaging. Some carriers have additional rules about transporting hazardous products. Follow your employer's rules when accepting shipments.

Shippers print required markings directly on the package, an attached label or tag. An important package marking is the name of the hazardous material. It is the same name as the one on the shipping paper. When required, the shipper will put the following on the package:

- Name and address of shipper or consignee (see 172.301(d)).
- Hazardous material's shipping name and ID number.
- Required labels.
- ID number on bulk packages.

**Package Markings and Labels** — If the rules require it, the shipper also will put RQ or INHALATION-HAZARD on the package. Packages with liquid containers inside also will have package orientation markings with the arrows pointing in the correct upright direction. The labels used always reflect the hazard class of the product. If a package needs more than one label, the labels will be close together, near the proper shipping name.

**Vehicle Markings** — Large quantities of hazardous materials in non-bulk packaging and certain quantities of INHALATION HAZARD materials in non-bulk packaging require additional marking on the transport vehicle. Specifically:

- A transport vehicle or freight container that contains 8,820 pounds (4,000 kg) or more non-bulk packages of a single hazardous material must be marked on each side and each end with the identification number for that product. The hazardous material must have the same proper shipping name and identification number and be loaded at one facility. The transport vehicle or freight container must contain no other material, hazardous or otherwise. The identification number may be displayed on the placard, an orange panel or white square on point device.
- A transport vehicle or freight container that contains 2,205 pounds (1,000 kg) or more non-bulk packages of a material identified as an INHALATION HAZARD, Hazard Zone A or B, must be marked on each side and each end with the identification number for those materials. The inhalation hazard material must have the same proper shipping name and identification number and be loaded all at one facility. The identification number may be displayed on a placard, an orange panel or white square on point device. Please refer to the 172.313 HMTR for specifics.
- Cargo tanks and other bulk containers require additional markings on the transport vehicle. "Bulk" is defined as a packaging with a maximum capacity greater than 119 gallons for liquid, including but not limited to such packagings as portable tanks, cargo tanks and tank cars. If required identification number markings on bulk containers are not visible while being transported (such as when loaded inside a closed semitrailer), the transport vehicle itself must also display on each side and each end the required identification number markings (see example on page 89).

**Recognizing Hazardous Materials** — Learn to recognize shipments of hazardous materials. To find out if the shipment includes hazardous materials, look at the shipping paper. Does it have:

- An entry with a proper shipping name, hazard class and ID number?
- A highlighted entry or one with an X or RQ in the hazardous materials column?

Other clues suggesting hazardous materials include:

- What business the shipper is in (e.g., paint dealer, chemical supply, scientific supply house, pest control or agricultural supplier, explosives, munitions or fireworks dealer).
- Tanks with diamond labels or placards on the premises.
- Type of package being shipped. Cylinders and drums often are used for hazardous materials shipments.
- Hazard class label, proper shipping name, or ID number on a package.
- Handling precautions noted.

**Hazardous Waste Manifest** — When transporting hazardous waste, you must sign by hand and carry a Uniform Hazardous Waste Manifest. The name and EPA registration number of the shippers, carriers and destination must appear on the manifest. Shippers must prepare, date and sign by hand the manifest. Treat the manifest as a shipping paper when transporting the waste. Only give the waste shipment to another registered carrier or disposal/treatment facility. Each carrier transporting the shipment must sign by hand the manifest. After you deliver the shipment, keep your copy of the manifest. Each copy must have all needed signatures and dates, including those of the person to whom you delivered the waste.

**Placarding** — Attach the appropriate placards to the vehicle before you drive it. You are only allowed to move an improperly placarded vehicle during an emergency in order to protect life or property.

Placards must appear on both sides and ends of the vehicle. Each placard must be:

- Easily seen from the direction it faces.
- Placed so the words or numbers are level and read from left to right.
- At least 3 inches away from any other markings.
- Kept clear of attachments or devices such as ladders, doors and tarpaulins.
- Kept clean and undamaged so that the color, format and message are easily seen.

To decide which placards to use, you need to know:

- The hazard class of materials.
- The amount of hazardous materials shipped.
- The total weight of all classes of hazardous materials in your vehicle.

Always make sure the shipper shows the correct basic description on a shipping paper and verifies that the proper labels are shown on the packages. If you are not familiar with the material, ask the shipper or contact your office.

**Placard Tables** — There are two placard tables (see page 95). Table 1 materials must be placarded whenever any amount is transported. Except for bulk packagings, the hazard classes in Table 2 need placards only if the total amount transported is 1,001 pounds or more, including the package. Add the amounts from all shipping papers for all Table 2 products you have on board. You may use DANGEROUS placards instead of separate placards for each Table 2 hazard class when:

- You have 1,001 pounds or more of two or more Table 2 hazard classes, requiring different placards, and
- You have not loaded 2,205 pounds or more of any Table 2 hazard class material at any one place. (You must use the specific placard for this material.)

If the words INHALATION HAZARD are on the shipping paper or package, you must display POISON or POISON INHALATION HAZARD or POISON GAS placards as appropriate, in addition to any other placards needed by the product's hazard class.

OXIDIZER placards are not required for Division 5.1 materials on freight containers, unit load devices, transport vehicles or rail cars also containing Division 1.1 or 1.2 materials and placarded with EXPLOSIVES 1.1 or 1.2 placards, as required. For transportation by transport vehicle or rail car only, an OXIDIZER placard is not required for Division 5.1 materials on a transport vehicle, rail car or freight container also containing Division 1.5 explosives and placarded with EXPLOSIVES 1.5 placards, as required.

A NON-FLAMMABLE GAS placard is not required on a transport vehicle containing non-flammable gas if the transport vehicle is placarded with FLAMMABLE GAS or OXYGEN placards, as required.

Placards used to identify the primary or subsidiary hazard class of a material must have the hazard class or division number displayed in the lower corner of the placard.



**Placard Table 1 – Any Amount**

<b>Category of Material (hazard class or division number and additional description, as appropriate)</b>	<b>Placard Name</b>	<b>Placard Design Section Reference (§)</b>
1.1	EXPLOSIVES 1.1	172.522
1.2	EXPLOSIVES 1.2	172.522
1.3	EXPLOSIVES 1.3	172.522
2.3	POISON GAS	172.540
4.3	DANGEROUS WHEN WET	172.548
5.2 (Organic peroxide, Type B, liquid or solid, temperature controlled)	ORGANIC PEROXIDE	172.522
6.1 (Other than material poisonous by inhalation – see 49 CFR 171.8 of this subchapter)	POISON INHALATION HAZARD	172.555
7 (Radioactive Yellow III label only)	RADIOACTIVE*	172.556

\*RADIOACTIVE placard also required for exclusive use shipments of low-specific activity material and surface contaminated objects transported in accordance with §173.427(a) of this subchapter.

**Placard Table 2 – 1,001 pounds or more**

<b>Category of Material (hazard class or division number and additional description, as appropriate)</b>	<b>Placard Name</b>	<b>Placard Design Section Reference (§)</b>
1.4	EXPLOSIVES 1.4	172.523
1.5	EXPLOSIVES 1.5	172.524
1.6	EXPLOSIVES 1.6	172.525
2.1	FLAMMABLE GAS	172.532
2.2	NON-FLAMMABLE GAS	172.528
3	FLAMMABLE	172.542
Combustible liquid	COMBUSTIBLE	172.544
4.1	FLAMMABLE SOLID	172.546
4.2	SPONTANEOUSLY COMBUSTIBLE	172.547
5.1	OXIDIZER	172.550
5.2 (Other than organic peroxide, Type B, liquid or solid, temperature controlled)	ORGANIC PEROXIDE	172.552
6.1 (Other than inhalation hazard, Zone A or B)	POISON	172.554
6.2	(None)	
8	CORROSIVE	172.558
9	CLASS 9 (see §172.504(f)(9))	172.560
ORM-D	(None)	

Placards may be displayed for hazardous materials even if not required so long as the placard identifies the hazard of the material being transported.

### Test Your Knowledge

1. What is a shipper's certification? Where does it appear? Who signs it?
2. When may non-hazardous materials be described by hazard class words or ID numbers?
3. Name five hazard classes that require placarding in any amount.
4. A shipment described on the Hazardous Waste Manifest may only be delivered to another (fill in the blank) carrier or treatment facility, which then signs the (fill in the blank), giving you a copy which you must keep.
5. What three kinds of emergency equipment must you have?

**These questions may be on the written exam.  
If you cannot answer all of them, study Sections 9.1 through 9.9.**

## 9.4 Loading and Unloading

**General Loading Requirements** — Do all you can to protect containers of hazardous materials. Do not use any tools that might damage containers or other packaging during loading. Do not use hooks.

- Before loading or unloading, set the parking brake. Make sure the vehicle will not move.
- Many products become more hazardous when exposed to heat. Load hazardous materials away from heat sources.
- Watch for signs of leaking or damaged containers: LEAKS SPELL TROUBLE! Do not transport leaking packages. Depending on the material, you, your truck and others could be in danger.

**Packages secured in a vehicle:** Any package containing any hazardous material, not permanently attached to a motor vehicle, must be secured against movement, including relative motion between packages, within the vehicle on which it is being transported, under conditions normally incident to transportation. Packages having valves or other fittings must be loaded in a manner to minimize the likelihood of damage during transportation.

**Secure against movement:** Brace containers so they will not fall, slide or bounce around during transportation. Be very careful when loading containers that have valves or other fittings.

After loading, do not open any package during your trip. Never transfer hazardous materials from one package to another while in transit. You may empty a cargo tank, but do not empty any other package while it is on the vehicle.

**No smoking:** When loading or unloading hazardous materials, keep fire away. Do not let people smoke nearby. Never smoke around:

Class 1	Division 2.1	Class 3	Class 4	Class 5
(explosives)	(flammable gas)	(flammable liquids)	(flammable solids)	(oxidizers)

**Cargo heater rules:** There are special cargo heater rules for loading:

Class 1	Division 2.1	Class 3
(explosives)	(flammable gas)	(flammable liquids)

The rules usually forbid the use of cargo heaters, including automatic cargo heater/air conditioner units. Unless you have read all the related rules, do not load the above products in a cargo space that has a heater.

**Use closed cargo space:** You cannot have overhang or tailgate loads of:

Class 1	Class 4	Class 5
(explosives)	(flammable solids)	(oxidizers)

You must load these hazardous materials into a closed cargo space unless all packages are:

- Fire and water resistant, or
- Covered with a fire and water resistant tarp.

### **Precautions for Specific Hazards —**

**Explosives:** Turn off your engine before loading or unloading any explosives. Then check the cargo space.

- Disable cargo heaters. Disconnect heater power sources and drain heater fuel tanks.
- Make sure there are no sharp points that might damage cargo. Look for bolts, screws, nails, broken side panels and broken floor boards.
- Vehicles transporting Division 1.1, 1.2, or 1.3 (explosive) materials must have tight floors with that portion of the interior in contact with the load lined with non-metallic material on non-ferrous metals.

Use extra care to protect explosives. Never use hooks or other metal tools. Never drop, throw or roll packages. Protect explosive packages from other cargo that might cause damage.

Do not transfer a Division 1.1, 1.2, or 1.3 (Class A or B explosive) from one vehicle to another on a public roadway except in an emergency. If safety requires an emergency transfer, set out red warning reflectors, flags or electric lanterns. You must warn others on the road.

Never transport damaged packages of explosives. Do not take a package that shows any dampness or oily stain.

- **Class I (explosive) materials on vehicles in combination** – Division 1.1 or 1.2 (explosive) materials may not be loaded into or carried on any vehicle or a combination of vehicles if:
  - More than two cargo carrying vehicles are in the combination,
  - Any fuller trailer in the combination has a wheel base of less than 184 inches,
  - Any vehicle in the combination is a cargo tank required to be marked or placarded under §177.823, or
  - The other vehicle in the combination contains any:
    - substances, explosive, n.o.s., Division 1.1A (explosive) material (initiating explosive),
    - packages of Class 7 (radioactive) materials bearing “Yellow III” labels,
    - division 2.3, Hazard Zone A or Hazard Zone B materials or Division 6.1, PG I, Hazard Zone A materials, or
    - hazardous materials in a portable tank or a DOT specification 106 A or 110A tank.
- **Class 2 (compressed gases) including cryogenic liquids** – If your vehicle does not have racks to hold cylinders, the cargo space floor must be flat. The cylinders must be:
  - Held upright or braced lying down flat, or
  - In racks attached to the vehicle, or
  - In boxes that will keep them from turning over.
- **Division 2.3 (poisonous gas) or Division 6.1 (poisonous) materials** – Never transport these materials in containers with interconnections. Never load a package labeled POISON, POISON-INHALATION HAZARD or POISON GAS in the driver’s cab or sleeper berth. Except for poisons marked or labeled as PGIII, never transport a package labeled POISON or POISON INHALATION HAZARD with foodstuffs or edible materials for human or animal consumption.
- **Class 7 (radioactive) materials** – Some packages of Class 7 (radioactive) materials bear a number called the “transport index.” The shipper labels these packages Radioactive II or Radioactive III, and prints the package’s transport index on the label. Radiation surrounds each package, passing through all nearby packages. To deal with this problem, the number of packages you can load together is controlled. Their closeness to people, animals and unexposed film also is controlled. The transport index tells the degree of control needed during transportation. The total transport index of all packages in a single vehicle must not exceed 50 (see Figure 9.7 on page 98).
- **Class 8 (corrosive) materials** – If loading by hand, load breakable containers of corrosive liquid one by one. Keep them right-side up. Do not drop or roll the containers. Load them onto an even floor surface. Stack carboys only if the lower tiers can bear the weight of the upper tiers safely.

### **Do not load nitric acid above any other product or stack more than two high.**

Load charged storage batteries so their liquid will not spill. Keep them right-side up. Make sure other cargo will not fall against or short circuit them.

Never load corrosive liquids next to or above:

- Division 1.4 (explosives C)
- Class 4 (flammable solids)
- Class 5 (oxidizers)
- Division 2.3, Zone B (poisonous gases)

Never load corrosive liquids with:

- Division 1.1 or 1.2 (explosives A)
- Division 1.2 or 1.3 (explosives B)
- Division 1.5 (blasting agents)
- Division 2.3, Zone A (poisonous gases)
- Division 4.2 (spontaneously combustible materials)
- Division 6.1, PG I, Zone A (poison liquids)

See Table on page 99 for rules for each transport index. It shows how close you can load Class 7 (radioactive) materials to people, animals or film. For example, you cannot leave a package with a transport index of 1.1 within 2 feet of people or cargo space walls. For mixed loads, refer to Figure 9-8.

**Figure 9-7  
Prohibited Loading  
Combinations**

**Class 7 (Radioactive) Material Bearing “Radioactive Yellow-II” or  
“Radioactive Yellow-III” Labels Distance Requirements**

Total transport index	Minimum separation distance in meters (feet) to nearest undeveloped film in various times of transit					Minimum distance in meters (feet) to area of persons, or minimum distance in meters (feet) from dividing partition of cargo compartments
	Up to 2 hours	2-4 hours	4-8 hours	8-12 hours	Over 12 hours	
None	0.0 (0)	0.0 (0)	0.0 (0)	0.0 (0)	0.0 (0)	0.0 (0)
0.1 to 1.0	0.3 (1)	0.6 (2)	0.9 (3)	1.2 (4)	1.5 (5)	0.3 (1)
1.1 to 5.0	0.9 (3)	1.2 (4)	1.8 (6)	2.4 (8)	3.4 (11)	0.6 (2)
5.1 to 10.0	1.2 (4)	1.8 (6)	2.7 (9)	3.4 (11)	4.6 (15)	0.9 (3)
10.1 to 20.0	1.5 (5)	2.4 (8)	3.7 (12)	4.9 (16)	6.7 (22)	1.2 (4)
20.1 to 30.0	2.1 (7)	3.0 (10)	4.6 (15)	6.1 (20)	8.8 (29)	1.5 (5)
30.1 to 40.0	2.4 (8)	3.4 (11)	5.2 (17)	6.7 (22)	10.1 (33)	1.8 (6)
40.1 to 50.0	2.7 (9)	3.7 (12)	5.8 (19)	7.3 (24)	11.0 (36)	2.1 (7)

Note: The distance in this table must be measured from the nearest point on the nearest packages of Class 7 (radioactive) material.

**Test Your Knowledge**

1. Around which five hazard classes must you never smoke?
2. Which three hazard classes should not be loaded into a trailer that has a heater/ai conditioner unit?
3. Should the floor liner required for Division 1.1 or 1.2 (Explosives A) be non-ferrous?
4. At the shipper's dock you are given a shipping paper for 100 cartons of battery acid. You already have 100 pounds of dry Silver Cyanide on board. What precautions do you have to take?
5. Name a hazard class that uses transport indexes to determine the amount that can be loaded in a single vehicle?

**These questions may be on the written exam.  
If you cannot answer all of them, study Section 9.4.**

Segregation Table for Hazardous Materials

Figure 9-8

Class or division	Notes	1.1 1.2	1.3	1.4	1.5	1.6	2.1	2.2	2.3 gas zone A	2.3 gas zone B	3	4.1	4.2	4.3	5.1	5.2	6.1 liquids PG I zone 2A	7	8 liquids only
Explosives	1.1 and 1.2 A	*	*	*	*	*	X	X	X	X	X	X	X	X	X	X	X	X	X
Explosives	1.3	*	*	*	*	*	X		X	X	X		X	X	X	X	X		X
Explosives	1.4	*	*	*	*	*	O		O	O	O		O				O		O
Very insensitive explosives	1.5 A	*	*	*	*	*	X	X	X	X	X	X	X	X	X	X	X	X	X
Extremely insensitive explosives	1.6	*	*	*	*	*													
Flammable gases	2.1	X	X	O	X				X	O							O	O	
Non-toxic, non-flammable gases	2.2	X			X														
Poisonous gas zone A	2.3	X	X	O	X		X				X	X	X	X	X	X			X
Poisonous gas zone B	2.3	X	X	O	X		O				O	O	O	O	O	O			O
Flammable liquids	3	X	X	O	X				X	O					O		X		
Flammable solids	4.1	X			X				X	O							X		O
Spontaneously combustible materials	4.2	X	X	O	X				X	O							X		X
Dangerous when wet materials	4.3	X	X		X				X	O							X		O
Oxidizers	5.1 A	X	X		X				X	O	O						X		O
Organic peroxides	5.2	X	X		X				X	O							X		O
Poisonous liquids PG I zone A	6.1	X	X	O	X				O		X	X	X	X					
Radioactive materials	7	X			X		O												
Corrosive liquids	8	X	X	O	X				X	O		O	X	O	O	O	X		

Instructions for using the segregating table for hazardous materials:

- (1) The absence of any Hazard Class or Division or a blank space in the table indicates that no restrictions apply.
- (2) The letter "X" in the table indicates that these materials may not be loaded, transported, or stored together in the same transport vehicle or storage facility during the course of transportation.
- (3) The letter "O" in the table indicates that these materials may not be loaded, transported, or stored together in the same transport vehicle or storage facility during the course of transportation unless separated in a manner that, in the event of leakage from packages under conditions normally incident to transportation, co-mingling of hazardous materials would not occur. Notwithstanding the methods of separation employed, Class 8 (corrosive) liquids may not be loaded above or adjacent to Class 4 (flammable) or Class 5 (oxidizing) materials; except that shippers may load truckload shipments of such materials together when it is known that the mixture of contents would not cause a fire or a dangerous evolution of heat or gas.
- (4) The "\*" in the table indicates that segregation among different Class 1 (explosive) materials is governed by the compatibility table in paragraph (f) of this section.
- (5) The note "A" in the second column of the table means that, notwithstanding the requirements of the letter "X," ammonium nitrate (UN 1942) and ammonium nitrate fertilizer may be loaded or stored with Division 1.1 (explosive) or Division 1.5 materials.
- (6) When the §172.101 table or §172.402 of this subchapter requires a package to bear a subsidiary hazard label, segregation appropriate to the subsidiary hazard must be applied when that segregation is more restrictive than that required by the primary hazard. However, hazardous materials of the same class may be stowed together without regard to segregation required for any secondary hazard if the materials are not capable of reacting dangerously with each other and causing combustion or dangerous evolution of heat, evolution of flammable, poisonous, or asphyxiant gases, or formation of corrosive or unstable materials.

## 9.5 Bulk Packaging Markings, Loading and Unloading

The glossary at the end of this section gives the meaning of the word “bulk.” **Cargo tanks** are bulk packagings permanently attached to a vehicle. Cargo tanks remain on the vehicle when you load and unload them. **Portable tanks** are bulk containers not permanently attached to a vehicle. The product is loaded or unloaded while the portable tanks are off the vehicle. Portable tanks are then put on a vehicle for transportation. There are many types of cargo tanks in use. The most common cargo tanks are MC306 for liquids and MC331 for gases.

**Markings** — You must display the ID number of the hazardous materials on portable tanks and cargo tanks and other bulk packagings (such as dump trucks). ID numbers are in column 4 of the Hazardous Materials Table. When required by Regulation Section 172.332(a), identification number markings must be displayed on orange panels or placards as specified in this section, or on white square-on-point configuration. Specification cargo tanks must show re-test date markings.

Portable tanks also must show the lessee or owner’s name and display the shipping name of the contents on two opposing sides. The letters of the shipping name must be at least 2-inches tall on portable tanks with capacities of more than 1,000 gallons and 1-inch tall on portable tanks with capacities of less than 1,000 gallons. The ID number must appear on each side and each end of a portable tank or other bulk packaging that holds 1,000 gallons or more and on two opposing sides, if the portable tank holds less than 1,000 gallons. The ID numbers must still be visible when the portable tank is on the motor vehicle. If they are not visible, you must display the ID number on both sides and ends of the motor vehicle.

**Tank Loading** — The person in charge of loading and unloading a cargo tank must be sure a qualified person is always watching. The person watching the loading or unloading must:

- Be alert.
- Have a clear view of the cargo tank and delivery hose.
- Be within 25 feet of the tank.
- Know of the hazards of the materials involved.
- Know the procedures to follow in an emergency.
- Be authorized to move the cargo tank and able to do so.

Close all manholes and valves before moving a tank of hazardous materials, no matter how small the amount in the tank or how short the distance. Manholes and valves must be closed to prevent leaks.

**Flammable Liquids** — Turn off your engine before loading or unloading any flammable liquids. Only run the engine if needed to operate a pump. Ground a cargo tank correctly before filling it through an open filling hole. Ground the tank before opening the filling hole, and maintain the ground until after closing the filling hole.

**Compressed Gas** — Keep liquid discharge valves on a compressed gas tank closed except when loading and unloading. Unless your engine runs a pump for product transfer, turn it off when loading or unloading. If you use the engine, turn it off after product transfer before unhooking the hose. Unhook all loading/unloading connections before coupling, uncoupling or moving a chlorine cargo tank. Always chock trailers and semitrailers to prevent motion when uncoupled from the power unit.

### Test Your Knowledge

1. What are cargo tanks?
2. How is a portable tank different from a cargo tank?
3. Your engine runs a pump used during delivery of compressed gas. Should you turn off the engine before or after unhooking hoses after delivery?

**These questions may be on the written exam.  
If you cannot answer all of them, study Section 9.5.**

## 9.6 Hazardous Materials — Driving & Parking (CFR Part 397 Motor Carrier Regulations)

Never park with Division 1.1, 1.2 or 1.3 (Class A or B) explosives within 5 feet of the traveled part of the road. Except for short periods of time needed for vehicle operation necessities (e.g. fueling), do not park within 300 feet of:

- a bridge, tunnel or building;
- a place where people gather; or
- an open fire.

**If you must park to do your job, do so only briefly.**

Do not park on private property unless the owner is aware of the danger. Someone must always watch the parked vehicle. You may let someone else watch it for you only if your vehicle is on the:

- shipper's property,
- carrier's property, or
- consignee's property.

You may leave your vehicle unattended in a safe haven. A safe haven is an approved place for parking unattended vehicles loaded with explosives. Local authorities usually make the designation of authorized safe havens.

**Parking Placarded Vehicle Not Transporting Division 1.1, 1.2 or 1.3 Explosives** — You may park a placarded vehicle (not laden with explosives) within 5 feet of the travelled part of the road only if your work requires it. Do so only briefly. Someone must always watch the vehicle when parked on a public roadway or shoulder. Do not uncouple a trailer and leave it with hazardous material on a public street. Do not park within 300 feet of an open fire.

**Attending Parked Vehicles** — The person watching a placarded vehicle must:

- Be in the vehicle awake, not in the sleeper berth, or within 100 feet of the vehicle and have it within clear view,
- Be aware of the hazards of the materials being transported,
- Know what to do in emergencies, and
- Be able to move the vehicle if needed.

**No Flares** — You may break down and have to use stopped vehicle signals. Use reflective triangles or red electric lights. **Never use burning signals, such as flares or fuses, around:**

- A tank used for Class 3 (flammable liquids) or Division 2.1 (flammable gas) whether loaded or empty.
- A vehicle loaded with Division 1.1, 1.2, or 1.3 (Class A or B) explosives.

**Route Restrictions** — Some states and counties require permits to transport hazardous materials or waste. They may limit the routes you can use. Local rules about routes and permits change often. It is your job as driver to find out if you need permits or must use special routes. Make sure you have all needed papers before starting.

If you work for a carrier, ask your dispatcher about route restrictions or permits. If you are an independent trucker and are planning a new route, check with state agencies where you plan to travel. Some localities prohibit transportation of hazardous materials through tunnels, over bridges or other roadways. Check before you start.

Whenever placarded, avoid heavily populated areas, crowds, tunnels, narrow streets and alleys. Take other routes, even if inconvenient, unless there is no other way. Never drive a placarded vehicle near open fires unless you can safely pass without stopping.

If transporting Division 1.1, 1.2 or 1.3 (Class A or Class B) explosives, you must have a written route plan and follow that plan. Carriers prepare the route plan in advance and give the driver a copy. You may plan the route yourself if you pick up the explosives at a location other than your employer's terminal. Write out the plan in advance. Keep a copy of it with you while transporting the explosives. Deliver shipments of explosives only to authorized persons or leave them in locked rooms designed for explosives storage.

A carrier must choose the safest route to transport placarded radioactive material. After choosing the route, the carrier must tell the driver about the radioactive materials and show the route plan.

**No Smoking** — Do not smoke within 25 feet of a placarded cargo tank used for Class 3 (flammable liquids) or Division 2.1 (gases). Also, do not smoke or carry a lighted cigarette, cigar or pipe within 25 feet of any vehicle that contains:

Class 1	Class 2.1	Class 3	Class 4	Class 5
(explosives)	(flammable gas)	(flammable liquids)	(flammable solids)	(oxidizers)

**Refuel With Engine Off** — Turn off the engine before fueling a motor vehicle containing hazardous materials. Someone must always be at the nozzle controlling fuel flow.

**A10 B:C Fire Extinguisher** — The power unit of placarded vehicles must have a fire extinguisher with a UL rating of 10 B:C or more.

**Check Tires** — Make sure your tires are properly inflated. Check placarded vehicles with dual tires at the start of each trip and when ever you park. You must examine **each** tire at the beginning of each trip and each time the vehicle is parked. The only acceptable way to check tire pressure is to use a tire pressure gauge.

Do not drive with a tire that is leaking or flat except to the nearest safe place to repair it. Remove any overheated tire. Place it a safe distance from your vehicle. Do not drive until you correct the cause of the overheating. Remember to follow the rules about parking and attending placarded vehicles. They apply even when checking, repairing or replacing tires.

**Displaying Shipping Papers and Emergency Response Information** — Do not accept a hazardous materials shipment without a properly prepared shipping paper. A shipping paper for hazardous material must always be easily recognized. Other people must be able to find it quickly after an accident.

- Clearly distinguish hazardous material shipping papers from others by tabbing them or keeping them on top of the stack of papers.
- When you are behind the wheel, keep shipping papers within your reach (with your seat belt on) or in a pouch on the driver's door. They must be easily seen by someone entering the cab.
- When not behind the wheel, leave shipping papers in the driver's door pouch or on the driver's seat.
- Emergency response information must be kept in the same location as the shipping paper.

**Papers for Division 1.1, 1.2 or 1.3 Explosives** — A carrier must give each driver transporting Division 1.1, 1.2 or 1.3 (Class A or B) explosives a copy of Federal Motor Carrier Safety Regulations (FMCSR), Part 397. The carrier also must give written instructions on what to do if delayed or in an accident. The written instructions must include:

- Names and telephone numbers of people to contact (including carrier agents or shippers).
- Nature of the explosives transported.
- Precautions to take in emergencies such as fires, accidents, or leaks.

Drivers must sign a receipt for these documents.

You must be familiar with and have in your possession while driving:

- Shipping papers.
- Written emergency instructions.
- Written route plan.
- Copy of FMCSR, Part 397.

**Equipment for Chlorine** — A driver transporting chlorine in cargo tanks must have an approved gas mask in the vehicle. The driver also must have an emergency kit for controlling leaks in dome cover plate fittings on the cargo tank.

**Stop Before Railroad Crossings** — Stop before a railroad crossing if your vehicle:

- Is placarded; or
- Carries any amount of chlorine; or
- Has cargo tanks, whether loaded or empty, used for hazardous materials.

You must stop 15 to 50 feet before the nearest rail. Proceed only when you are sure no train is coming. Do not shift gears while crossing the tracks.

## 9.7 Hazardous Materials — Emergencies

**Emergency Response Guidebook** — The Department of Transportation has an Emergency Response Guidebook for firefighters, police and industry workers on how to protect themselves and the public from hazardous materials. The guide is indexed by proper shipping name and hazardous materials identification number. Emergency personnel look for these things on the shipping paper. That is why it is vital that the proper shipping name, ID number, label and placards are correct.

**Accidents/Incidents** — As a professional driver, your job at the scene of an accident is to:

- Keep people away from the scene.
- Limit the spread of material, **only if you can safely do so**.
- Communicate the danger of the hazardous materials to emergency response personnel.
- Provide emergency responders with the shipping papers and emergency response information.



Follow this checklist:

- Check to see that your driving partner is OK.
- Keep shipping papers with you.
- Keep people far away and upwind.
- Warn others of the danger.
- Send for help.
- Follow your employer's instructions.

**Fires** — You might have to control minor truck fires on the road. **However, unless you have the training and equipment to do so safely, do not fight hazardous material fires.** Dealing with hazardous material fires requires special training and protective gear.

When you discover a fire, send someone for help. You may use the fire extinguisher to keep minor truck fires from spreading to cargo before firefighters arrive. Feel trailer doors to see if they are hot before opening them. If hot, you may have a cargo fire and should not open the doors. Opening doors lets air in and may make the fire flare up. Without air, many fires only smolder until firemen arrive, doing less damage. If your cargo is already on fire, it is not safe to fight the fire. Keep the shipping papers with you to give to emergency personnel as soon as they arrive. **Warn other people of the danger and keep them away.**

If you discover a cargo leak, identify the hazardous materials leaking by using shipping papers, labels or package location. **Do not touch any leaking material — many people injure themselves by touching hazardous materials.** Do not try to identify the material or find the source of a leak by smell. Many toxic gases destroy your sense of smell and can injure or kill you even if they do not smell. Never eat, drink or smoke around a leak or spill.

If hazardous materials are spilling from your vehicle, do not move it any more than safety requires. You may move off the road and away from places where people gather, if doing so serves safety. Only move your vehicle if you can do so without danger to yourself or others.

Never continue driving with hazardous material leaking from your vehicle to find a phone booth, truck stop, help or other reason. Remember that the carrier pays for the cleanup of contaminated parking lots, roadways and drainage ditches. The costs are enormous, so do not leave a lengthy trail of contamination. If hazardous materials are spilling from your vehicle:

- Park it.
- Secure the area.
- Stay there.
- Send someone else for help.

When sending someone for help, give that person:

- A description of the emergency.
- Your exact location and direction of travel.
- Your name, the carrier's name, and the name of the community or city where your terminal is located.
- The shipping name, hazard class and ID number of the hazardous materials, if you know them.

This is a lot to remember, so it is a good idea to write it all down for the person you send for help. The emergency response team must know these things to find you and to handle the emergency. They may have to travel miles to get to you. This information will help them to bring the appropriate equipment the first time, without having to go back for it.

Never move your vehicle if doing so will cause contamination or damage the vehicle. Keep downwind and away from roadside rests, truckstops, cafes and businesses. Never try to repack leaking containers. Unless you have the training and equipment to repair leaks safely, do not try it. Call your dispatcher or supervisor for instructions and, if needed, emergency personnel.

### **Responses to Specific Hazards —**

**Class 1 (explosives):** If your vehicle has a breakdown or accident while carrying explosives, warn others of the danger. Keep bystanders away. Do not allow smoking or open fire near the vehicle. If there is a fire, warn everyone of the danger of explosion.

Remove all explosives before pulling apart vehicles involved in a collision. Place the explosives at least 300 feet from the vehicles and occupied buildings. Stay a safe distance away.

**Class 2 (compressed gases):** If compressed gas is leaking from your vehicle, warn others of the danger. Only permit those involved in removing the hazard or wreckage to get close. You must notify the shipper if compressed gas is involved in any accident.

Unless you are fueling machinery used in road construction or maintenance, do not transfer a flammable compressed gas from one tank to another on any public roadway.

**Class 3 (flammable liquids):** If you are transporting a flammable liquid and have an accident or your vehicle breaks down, prevent bystanders from gathering. Warn people of the danger. Keep them from smoking.

Never transport a leaking cargo tank farther than needed to reach a safe place. Get off the roadway if you can do so safely. Do not transfer flammable liquid from one vehicle to another on a public roadway except in an emergency.

**Class 4 (flammable solids) and Class 5 (oxidizing materials):** If a flammable solid or oxidizing material spills, warn others of the fire hazard. Do not open smoldering packages of flammable solids. Remove them from the vehicle if you can safely do so. Also, remove unbroken packages if it will decrease the fire hazard.

**Class 6 (poisonous materials and infectious substances):** It is your job to protect yourself, other people and property from harm. Remember that many products classed as poison also are flammable. If you think a Division 2.3 (poisonous gases) or Division 6.1 (poisonous materials) might be flammable, take the added precautions needed for flammable liquids or gases. Do not allow smoking, open flame or welding. Warn others of the hazards of fire, inhaling vapors or coming in contact with the poison.

A vehicle involved in a leak of Division 2.3 (poisonous gases) or Division 6.1 (poisonous materials) must be checked for stray poison before being used again.

If a Division 6.2 (infectious substances) package is damaged in handling or transportation, you should immediately contact your supervisor. Packages that appear to be damaged or shows signs of leakage should not be accepted.

**Class 7 (radioactive materials):** If radioactive material is involved in a leak or broken package, tell your dispatcher or supervisor as soon as possible. If there is a spill, or if an internal container might be damaged, do not touch or inhale the material. Do not use the vehicle until it is cleaned and checked with a survey meter.

**Class 8 (corrosive materials):** If corrosives spill or leak during transportation, be careful to avoid further damage or injury when handling the containers. Parts of the vehicle exposed to a corrosive liquid must be thoroughly washed with water. After unloading, wash out the interior as soon as possible before reloading.

If continuing to transport a leaking tank would be unsafe, get off the road. If safe to do so, try to contain any liquid leaking from the vehicle. Keep bystanders away from the liquid and its fumes. Do everything possible to prevent injury to others.

**Required Notification** — The National Response Center helps coordinate emergency response to chemical hazards. It is a resource to the local police and firefighters. The center maintains a 24-hour, toll-free line. You or your employer must call the center when **any** of the following occur **as a direct result of a hazardous materials incident per 171.15:**

- (a) General. As soon as practical but no later than 12 hours after the occurrence of any incident described in paragraph (b) of this section, each person in physical possession of the hazardous material must provide notice by telephone to the National Response Center (NRC) on 800-424-8802 (toll free) or 202-267-2675 (toll call). Notice involving an infectious substance (etiologic agent) may be given to the Director, Centers for Disease Control and Prevention, U.S. Public Health Service, Atlanta, GA, 800-232-0124 (toll free), in place of notice to the NRC. Each notice must include the following information:
  - (a)(1) Name of reporter;
  - (a)(2) Name and address of person represented by reporter;
  - (a)(3) Phone number where reporter can be contacted;
  - (a)(4) Date, time, and location of incident;
  - (a)(5) The extent of injury, if any;
  - (a)(6) Class or division, proper shipping name, and quantity of hazardous materials involved, if such information is available; and
  - (a)(7) Type of incident and nature of hazardous material involvement and whether a continuing danger to life exists at the scene.

- (b) Reportable incident. A telephone report is required whenever any of the following occurs during the course of transportation in commerce (including loading, unloading, and temporary storage):
- (b)(1) As a direct result of a hazardous material;
    - (b)(1)(i) A person is killed;
    - (b)(1)(ii) A person receives an injury requiring admittance to a hospital;
    - (b)(1)(iii) The general public is evacuated for one hour or more;
    - (b)(1)(iv) A major transportation artery or facility is closed or shut down for one hour or more; or
    - (b)(1)(v) The operational flight pattern or routine of an aircraft is altered;
  - (b)(2) Fire, breakage, spillage, or suspected radioactive contamination occurs involving a radioactive material (see also §176.48 of this subchapter);
  - (b)(3) Fire, breakage, spillage, or suspected contamination occurs involving an infectious substance other than a diagnostic specimen or regulated medical waste;
  - (b)(4) A release of a marine pollutant occurs in a quantity exceeding 450 L (119 gallons) for a liquid or 400 kg (882 pounds) for a solid; or
  - (b)(5) A situation exists of such a nature (e.g., a continuing danger to life exists at the scene of the incident) that, in the judgment of the person in possession of the hazardous material, it should be reported to the NRC even though it does not meet the criteria of paragraph (b)(1), (2), (3) or (4) of this section.

Persons telephoning the National Response Center should be ready to give:

- Their name.
- Name and address of the carrier they work for.
- Phone number where they can be reached.
- Date, time and location of incident.
- The extent of injuries, if any.
- Classification, name and quantity of hazardous materials involved, if such information is available.
- Type of incident and nature of hazardous material involvement and whether a continuing danger to life exists at the scene.

**National Response Center**  
**800-424-8802**

If a reportable quantity of hazardous substance was involved, the caller should give the name of the shipper and the quantity of the hazardous substance discharged.

Be prepared to give your employer the required information as well. Carriers must make detailed written reports within 30 days of an incident.

The Chemical Transportation Emergency Center (CHEMTREC) in Washington, D.C., also has a 24-hour, toll-free line. CHEMTREC was created to provide emergency personnel with technical information about the physical properties of hazardous materials. The National Response Center and CHEMTREC are in close communication. If you call either one, they will tell the other about the problem when appropriate.

**CHEMTREC**  
**800-424-9300**

## Test Your Knowledge

1. When should a driver check the tires?
2. What is a safe haven?
3. How close to the travelled part of the roadway can you park with Division 1.2 or 1.3?
4. What type of fire extinguisher must placarded vehicles carry?
5. You are hauling 100 pounds of **Division 4.3 (dangerous when wet)** material. Do you need to stop before railroad crossings?
6. At a rest area you discover your hazardous materials shipments slowly leaking from the vehicle. There is no phone around. What should you do?
7. What is the Emergency Response Guide?

**These questions may be on the written exam.  
If you cannot answer all of them, study Sections 9.6 and 9.7.**

<b>Table A – Radioactive Separation Table</b>						
<b>Total transport index</b>	<b>Minimum separation distance in meters (feet) to nearest undeveloped film in various times of transit</b>					<b>Minimum distance in meters (feet) to area of persons, or minimum distance in meters (feet) from dividing partition of cargo compartments</b>
	<b>Up to 2 hours</b>	<b>2-4 hours</b>	<b>4-8 hours</b>	<b>8-12 hours</b>	<b>Over 12 hours</b>	
None	0.0 (0)	0.0 (0)	0.0 (0)	0.0 (0)	0.0 (0)	0.0 (0)
0.1 to 1.0	0.3 (1)	0.6 (2)	0.9 (3)	1.2 (4)	1.5 (5)	0.3 (1)
1.1 to 5.0	0.9 (3)	1.2 (4)	1.8 (6)	2.4 (8)	3.4 (11)	0.6 (2)
5.1 to 10.0	1.2 (4)	1.8 (6)	2.7 (9)	3.4 (11)	4.6 (16)	0.9 (3)
10.1 to 20.0	1.5 (5)	2.4 (8)	3.7 (12)	4.9 (16)	6.7 (22)	1.2 (4)
20.1 to 30.0	2.1 (7)	3.0 (10)	4.6 (16)	6.1 (20)	8.8 (29)	1.5 (5)
30.1 to 40.0	2.4 (8)	3.4 (11)	5.2 (17)	6.7 (22)	10.1 (33)	1.8 (6)
40.1 to 50.0	2.7 (9)	3.7 (12)	5.8 (19)	7.3 (24)	11.0 (36)	2.1 (7)

Note: The distance in this table must be measured from the nearest point on the nearest packages of Class 7 (radioactive) material.

<b>Table B – Kinds of Hazardous Materials</b>		
<b>Class</b>		
1	Explosives	Ammunition, Dynamite, Fireworks
2	Gases	Propane, Oxygen, Helium
3	Flammable & Combustible Liquid	Gasoline, Acetone, Diesel Fuel
4	Flammable Solids	Matches, Safety
5	Oxidizers	Ammonium Perchlorate, Hydrogen Peroxide
6	Poisons	Pesticides, Arsenic
7	Radioactive	Uranium, Plutonium
8	Corrosives	Hydrochloric Acid, Battery Acid
9	Miscellaneous Hazardous Materials	Asbestos, Environmentally Hazardous Substances n.o.s.
None	ORM-D (Other Regulated Material-Domestic)	Hairspray, Consumer Commodity (Defined in 49 CFR 171.8)

## Table C – Federal Motor Carrier Safety Regulations

### §391.11 General qualifications of drivers.

(a) A person shall not drive a commercial motor vehicle unless he/she is qualified to drive a commercial motor vehicle. Except as provided in §391.63, a motor carrier shall not require or permit a person to drive a commercial motor vehicle unless that person is qualified to drive a commercial motor vehicle.

(b) Except as provided in Subpart G of this part, a person is qualified to drive a motor vehicle if he/she —

(b)(1) Is at least 21 years old;

(b)(2) Can read and speak the English language sufficiently to converse with the general public, to understand highway traffic signs and signals in the English language, to respond to official inquiries, and to make entries on reports and records;

(b)(3) Can, by reason of experience, training, or both, safely operate the type of commercial motor vehicle he/she drives;

(b)(4) Is physically qualified to drive a commercial motor vehicle in accordance with Subpart E — Physical Qualifications and Examinations of this part;

(b)(5) Has a currently valid commercial motor vehicle operator's license issued only by one State or jurisdiction;

(b)(6) Has prepared and furnished the motor carrier that employs him/her with the list of violations or the certificate as required by §391.27;

(b)(7) Is not disqualified to drive a commercial motor vehicle under the rules in §391.15; and

(b)(8) Has successfully completed a driver's road test and has been issued a certificate of driver's road test in accordance with §391.31, or has presented an operator's license or a certificate of road test which the motor carrier that employs him/her has accepted as equivalent to a road test in accordance with §391.33.

[35 FR 6460, Apr. 22, 1970, as amended at 35 FR 17420, Nov. 13, 1970; 35 FR 19181, Dec. 18, 1970; 36 FR 222, Jan. 7, 1971, 36 FR 24220, Dec. 22, 1971; 45 FR 46424, July 10, 1980; 52 FR 20589, June 1, 1987; 59 FR 60323, Nov. 23, 1994; 60 FR 38744, 38745, July 28, 1995; 63 FR 33276, June 18, 1998].

### §391.41 Physical qualifications for drivers.

(a) A person shall not drive a commercial motor vehicle unless he/she is physically qualified to do so and, except as provided in §391.67, has on his/her person the original, or a photographic copy, of a medical examiner's certificate that he/she is physically qualified to drive a commercial motor vehicle.

The United States and Canada entered into a Reciprocity Agreement, effective March 30, 1999, recognizing that a Canadian commercial driver's license is proof of medical fitness to drive. Therefore, Canadian commercial motor vehicle (CMV) drivers are no longer required to have in their possession a medical examiner's certificate if the driver has been issued, and possesses, a valid commercial driver's license issued by a Canadian Province or Territory. However, Canadian drivers who are insulin-using diabetics, who have epilepsy, or who are hearing impaired as defined in §391.41(b)(11) are not qualified to drive CMVs in the United States. Furthermore, Canadian drivers who do not meet the medical fitness provisions of the Canadian National Safety Code for Motor Carriers but who have been issued a waiver by one of the Canadian Provinces or Territories are not qualified to drive CMVs in the United States.

(b) A person is physically qualified to drive a commercial motor vehicle if that person

(b)(1) Has no loss of a foot, a leg, a hand, or an arm, or has been granted a skill performance evaluation certificate pursuant to §391.49;

(b)(2) Has no impairment of:

(b)(2)(i) A hand or finger which interferes with prehension or power grasping; or

(b)(2)(ii) An arm, foot, or leg which interferes with the ability to perform normal tasks associated with operating a commercial motor vehicle; or any other significant limb defect or limitation which interferes with the ability to perform normal tasks associated with operating a commercial motor vehicle; or has been granted a skill performance evaluation certificate pursuant to §391.49.

(b)(3) Has no established medical history or clinical diagnosis of diabetes mellitus currently requiring insulin for control;

(b)(4) Has no current clinical diagnosis of myocardial infarction, angina pectoris, coronary insufficiency, thrombosis, or any other cardiovascular disease of a variety known to be accompanied by syncope, dyspnea, collapse, or congestive cardiac failure;

(b)(5) Has no established medical history or clinical diagnosis of a respiratory dysfunction likely to interfere with his/her ability to control and drive a commercial motor vehicle safely;

(b)(6) Has no current clinical diagnosis of high blood pressure likely to interfere with his/her ability to operate a commercial motor vehicle safely;

(b)(7) Has no established medical history or clinical diagnosis of rheumatic, arthritic, orthopedic, muscular, neuromuscular, or vascular disease which interferes with his/her ability to control and operate a commercial motor vehicle safely;

(b)(8) Has no established medical history or clinical diagnosis of epilepsy or any other condition which is likely to cause loss of consciousness or any loss of ability to control a commercial motor vehicle;

(b)(9) Has no mental, nervous, organic, or functional disease or psychiatric disorder likely to interfere with his/her ability to drive a commercial motor vehicle safely;

(b)(10) Has distant visual acuity of at least 20/40 (Snellen) in each eye without corrective lenses or visual acuity separately corrected to 20/40 (Snellen) or better with corrective lenses, distant binocular acuity of at least 20/40 (Snellen) in both eyes with or without corrective lenses, field of vision of at least 70° in the horizontal meridian in each eye, and the ability to recognize the colors of traffic signals and devices showing standard red, green, and amber;

(b)(11) First perceives a forced whispered voice in the better ear at not less than 5 feet with or without the use of a hearing aid or, if tested by use of an audiometric device, does not have an average hearing loss in the better ear greater than 40 decibels at 500 Hz, 1,000 Hz, and 2,000 Hz with or without a hearing aid when the audiometric device is calibrated to American National Standard (formerly ASA Standard) Z24.5-1951;

(b)(12)(i) Does not use a controlled substance identified in 21 CFR 1308.11 Schedule I, an amphetamine, a narcotic, or any other habit-forming drug.

(b)(12)(ii) *Exception.* A driver may use such a substance or drug, if the substance or drug is prescribed by a licensed medical practitioner who:

(b)(12)(ii)(A) Is familiar with the driver's medical history and assigned duties; and

(b)(12)(ii)(B) Has advised the driver that the prescribed substance or drug will not adversely affect the driver's ability to safely operate a commercial motor vehicle; and

(b)(13) Has no current clinical diagnosis of alcoholism.

[35 FR 6460, Apr. 22, 1970, as amended at 35 FR 17420, Nov. 13,

1970; 36 FR 223, Jan. 7, 1971; 36 FR 12857, July 8, 1971; 43 FR 56900, Dec. 5, 1978; 51 FR 17571, May 13, 1986; 53 FR 18057, May 19, 1988; 53 FR 47154, Nov. 21, 1988; 55 FR 3554, Feb. 1, 1990; 60 FR 38744, 38745, July 28, 1995; 62 FR 37152, July 11, 1997; 65 FR 59369, Oct 5, 2000]

**§391.45 Persons who must be medically examined and certified.**

Except as provided in §391.67, the following persons must be medically examined and certified in accordance with §391.43 as physically qualified to operate a commercial motor vehicle:

(a) Any person who has not been medically examined and certified as physically qualified to operate a commercial motor vehicle;

(b)(1) Any driver who has not been medically examined and certified as qualified to operate a commercial motor vehicle during the preceding 24 months; or

(b)(2) Any driver authorized to operate a commercial motor vehicle only with an exempt intracity zone pursuant to §391.62, or only by operation of the exemption in §391.64, if such driver has not been medically examined and certified as qualified to drive in such zone during the preceding 12 months; and

(c) Any driver whose ability to perform his/her normal duties has been impaired by a physical or mental injury or disease.

[35 FR 6460, Apr. 22, 1970, as amended at 36 FR 223, Jan. 7, 1971; 54 FR 12202, Mar. 24, 1989].

**§383.51 Disqualification of drivers.**

(a) **General.** (1) A driver or holder of a CDL who is disqualified

must not drive a CMV.

(a)(2) An employer must not knowingly allow, require, permit, or authorize a driver who is disqualified to drive a CMV.

(a)(3) A driver is subject to disqualification sanctions designated in paragraphs (b) and (c) of this section, if the holder of a CDL drives a CMV or non-CMV and is convicted of the violations.

(a)(4) Determining first and subsequent violations. For purposes of determining first and subsequent violations of the offenses specified in this subpart, each conviction for any offense listed in Tables 1 through 4 to this section resulting from a separate incident, whether committed in a CMV or non-CMV, must be counted.

(a)(5) Reinstatement after lifetime disqualification. A State may reinstate any driver disqualified for life for offenses described in paragraphs (b)(1) through (b)(8) of this section (Table 1 to §383.51) after 10 years if that person has voluntarily entered and successfully completed an appropriate rehabilitation program approved by the State. Any person who has been reinstated in accordance with this provision and who is subsequently convicted of a disqualifying offense described in paragraphs (b)(1) through (b)(8) of this section (Table 1 to §383.51) must not be reinstated.

(b) **Disqualification for major offenses.** Table 1 to §383.51 contains a list of the offenses and periods for which a driver must be disqualified, depending upon the type of vehicle the driver is operating at the time of the violation, as follows:

**Table 1 to §383.51**

If a driver operates a motor vehicle and is convicted of:	For a first conviction or refusal to be tested while operating a CMV, a person required to have a CDL and a CDL holder must be disqualified from operating a CMV for:	For a first conviction or refusal to be tested while operating a non-CMV, a CDL holder must be disqualified from operating a CMV for:	For a first conviction or refusal to be tested while operating a CMV transporting hazardous materials required to be placarded under the Hazardous Materials Regulations (49 CFR part 172, subpart F), a person required to have a CDL and CDL holder must be disqualified from operating a CMV for:	For a second conviction or refusal to be tested in a separate incident of any combination of offenses in this Table while operating a CMV, a person required to have a CDL and a CDL holder must be disqualified from operating a CMV for:	For a second conviction or refusal to be tested in a separate incident of any combination of offenses in this Table while operating a non-CMV, a CDL holder must be disqualified from operating a CMV for:
(1) Being under the influence of alcohol as prescribed by State law.	1 year	1 year	3 years	Life	Life
(2) Being under the influence of a controlled substance.	1 year	1 year	3 years	Life	Life
(3) Having an alcohol concentration of .04 percent or greater while operating a CMV.	1 year	Not applicable	3 years	Life	Not applicable
(4) Refusing to take an alcohol test as required by a State or jurisdiction under its implied consent laws or regulations as defined in §383.72 of this part.	1 year	1 year	3 years	Life	Life

(5) Leaving the scene of an accident.	1 year	1 year	3 years	Life	Life
(6) Using the vehicle to commit a felony other than a felony described in paragraph (b)(9) of this table.	1 year	1 year	3 years	Life	Life
(7) Driving a CMV when, as a result of prior violations committed operating a CMV, the driver's GDL is revoked, suspended, or canceled, or the driver is disqualified from operating a CMV.	1 year	Not applicable	3 years	Life	Not applicable
(8) Causing a fatality through the negligent operation of a CMV, including but not limited to the crimes of motor vehicle manslaughter, homicide by motor vehicle and negligent homicide.	1 year	Not applicable	3 years	Life	Not applicable
(9) Using the vehicle in the commission of a felony involving manufacturing, distributing, or dispensing a controlled substance.	Life-not eligible for 10-year reinstatement	Life-not eligible for 10-year reinstatement	Life-not eligible for 10-year reinstatement	Life-not eligible for 10-year reinstatement	Life-not eligible for 10-year reinstatement

(c) **Disqualification for serious traffic violations.** Table 2 to §383.51 contains a list of the offenses and the periods for which a driver must be disqualified, depending upon the type of vehicle the driver is operating at the time of the violation, as follows:

<p><b>Table 2 to §383.51</b> If a driver operates a motor vehicle and is convicted of:</p>	For a second conviction of any combination of offenses in this Table in a separate incident within a 3-year period while operating a CMV, a person required to have a CDL and a CDL holder must be disqualified from operating a CMV for:	For a second conviction of any combination of offenses in this Table in a separate incident within a 3-year period while operating a non-CMV, a CDL holder must be disqualified from operating a CMV, if the conviction results in the revocation, cancellation, or suspension of the CDL holder's license or non-CMV driving privileges, for:	For a third or subsequent conviction of any combination of offenses in this Table in a separate incident within a 3-year period while operating a CMV, a person required to have a CDL and a CDL holder must be disqualified from operating a CMV for:	For a third or subsequent conviction of any combination of offenses in this Table in a separate incident within a 3-year period while operating a non-CMV, a CDL holder must be disqualified from operating a CMV, if the conviction results in the revocation, cancellation, or suspension of the CDL holder's license or non-CMV driving privileges, for:	
	(1) Speeding excessively, involving any speed of 24.1 kph (15 mph) or more above the posted speed limit.	60 days	60 days	120 days	120 days
	(2) Driving recklessly, as defined by State or local law or regulation, including but not limited to, offenses of driving a motor vehicle in willful or wanton disregard for the safety of persons or property.	60 days	60 days	120 days	120 days



(3) Making improper or erratic traffic lane changes.	60 days	60 days	120 days	120 days
(4) Following the vehicle ahead too closely.	60 days	60 days	120 days	120 days
(5) Violating State or local law relating to motor vehicle traffic control (other than a parking violation) arising in connection with a fatal accident.	60 days	60 days	120 days	120 days
(6) Driving a CMV without obtaining a CDL.	60 days	Not applicable	120 days	Not applicable
(7) Driving a CMV without a CDL in the driver's possession. <sup>1</sup>	60 days	Not applicable	120 days	Not applicable
(8) Driving a CMV without the proper class of CDL and/or endorsements for the specific vehicle group being operated or for the passengers or type of cargo being transported.	60 days	Not applicable	120 days	Not applicable

<sup>1</sup> Any individual who provides proof to the enforcement authority that issued the citation, by the date the individual must appear in court or pay any fine for such a violation, that the individual held a valid CDL on the date the citation was issued, shall not be guilty of this offense.

(d) **Disqualification for railroad-highway grade crossing offenses.** Table 3 to §383.51 contains a list of the offenses and the periods for which a driver must be disqualified, when the driver is operating a CMV at the time of the violation, as follows:

**Table 3 to §383.51**

If a driver is convicted of operating a CMV in violation of a federal, state or local law because:	For a first conviction a person required to have a CDL and a CDL holder must be disqualified from operating a CMV for:	For a second conviction of any combination of offenses in this Table in a separate incident within a 3-year period a person required to have a CDL and a CDL holder must be disqualified from operating a CMV for:	For a third or subsequent conviction of any combination of offenses in this Table in a separate incident within a 3-year period a person required to have a CDL and a CDL holder must be disqualified from operating a CMV for:
(1) The driver is not required to always stop, but fails to slow down and check that tracks are clear of an approaching train.	No less than 60 days	No less than 120 days	No less than 1 year.
(2) The driver is not required to always stop, but fails to stop before reaching the crossing, if the tracks are not clear.	No less than 60 days	No less than 120 days	No less than 1 year.
(3) The driver is always required to stop, but fails to stop before driving onto the crossing.	No less than 60 days	No less than 120 days	No less than 1 year.
(4) The driver fails to have sufficient space to drive completely through the crossing without stopping.	No less than 60 days	No less than 120 days	No less than 1 year.
(5) The driver fails to obey a traffic control device or the directions of an enforcement official at the crossing.	No less than 60 days	No less than 120 days	No less than 1 year.
(6) The driver fails to negotiate a crossing because of insufficient undercarriage clearance.	No less than 60 days	No less than 120 days	No less than 1 year.

(e) **Disqualification for violating out-of-service orders.** Table 4 to §383.51 contains a list of the offenses and periods for which a driver must be disqualified when the driver is operating a CMV at the time of the violation, as follows:

**Table 4 to § 383.51**

If a driver operates a CMV and is convicted of:	For a first conviction while operating a CMV, a person required to have a CDL and a CDL holder must be disqualified from operating a CMV for:	For a second conviction in a separate incident within a 10-year period while operating a CMV, a person required to have a CDL and a CDL holder must be disqualified from operating a CMV for:	For a third or subsequent conviction in a separate incident within a 10-year period while operating a CMV, a person required to have a CDL and a CDL holder must be disqualified from operating a CMV for:
(1) Violating a driver or vehicle out-of-service order while transporting nonhazardous materials.	No less than 90 days or more than 1 year.	No less than 1 year or more than 5 years.	No less than 3 years or more than 5 years.
(2) Violating a driver or vehicle out-of-service order while transporting hazardous materials required to be placarded under part 172, subpart F of this title, or while operating a vehicle designed to transport 16 or more passengers, including the driver.	No less than 180 days or more than 2 years.	No less than 3 years or more than 5 years.	No less than 3 years or more than 5 years.

[52 FR 20587, June 1, 1987, as amended at 53 FR 39050, Oct. 4, 1988; 54 FR 40788, Oct. 3, 1989; 55 FR 6727, Feb. 26, 1990; 57 FR 53295, Nov. 9, 1992; 59 FR 26028, May 18, 1994; 62 FR 37151, July 11, 1997; 64 FR 48111, Sept 2, 1999; [67 FR 49756, Jul. 31, 2002; 68 FR 4397, Jan. 29, 2003]

## HAZARDOUS MATERIALS GLOSSARY

This glossary presents definitions of certain terms used in this section. A complete glossary of terms can be found in the federal Hazardous Materials Rules (49 CFR 171.8). You should have an up-to-date copy of these rules for your reference. **You will not be tested on this glossary.**

Sec. 171.8 Definitions and abbreviations.

**Bulk packaging** – A packaging, other than a vessel or a barge, including a transport vehicle or freight container, in which hazardous materials are loaded with no intermediate form of containment and which has:

- (1) A maximum capacity greater than 450 L (119 gallons) as a receptacle for a liquid;
- (2) A maximum net mass greater than 400 kg (882 pounds) and a maximum capacity greater than 450 L (119 gallons) as a receptacle for a solid; or
- (3) A water capacity greater than 454 kg (1000 pounds) as a receptacle for a gas as defined in Sec. 173.115.

**Cargo tank** – A bulk packaging that:

- (1) Is a tank intended primarily for the carriage of liquids or gases and includes appurtenances, reinforcements, fittings, and closures (for “tank,” see 49 CFR 178.345-1(c), 178.337-1, or 178.338-1, as applicable);
- (2) is permanently attached to or forms a part of a motor vehicle, or is not permanently attached to a motor vehicle but which, by reason of its size, construction or attachment to a motor vehicle, is loaded or unloaded without being removed from the motor vehicle; and
- (3) is not fabricated under a specification for cylinders, portable tanks, tank cars, or multi-unit tank car tanks.

**Carrier** – A person engaged in the transportation of passengers or property by:

- (1) Land or water as a common, contract, or private carrier, or
- (2) Civil aircraft.

**Consignee** – The business or person to whom a shipment is delivered.

**Division** – A subdivision of a hazard class

**EPA** – U.S. Environmental Protection Agency

**FMCSR** – Federal Motor Carrier Safety Regulations

**Freight container** – A reusable container having a volume of 64 cubic feet or more, designed and constructed to permit being lifted with its contents intact and intended primarily for containment of packages (in unit form) during transportation.

**Fuel tank** – A tank, other than a cargo tank, used to transport flammable or combustible liquid or compressed gas for the purpose of supplying fuel for propulsion of the transport vehicle to which it is attached, or for the operation of other equipment on the transport vehicle.

**Gross weight or gross mass** – The weight of a packaging plus the weight of its contents.

**Hazard class** – The category of hazard assigned to a hazardous material under the definitional criteria of Part 173 and the provisions of the Sec. 172.i01 Table. A material may meet the defining criteria for more than one hazard class but is assigned to only one hazard class.

**Hazardous materials** – A substance or material that has been determined by the Secretary of Transportation to be capable of posing an unreasonable risk to health, safety and property when transported in commerce, and which has been so designated. The term includes hazardous substances, hazardous wastes, marine pollutants, and elevated temperature materials as defined in this section, materials designated as hazardous under the provisions of Sec. 172.101 and 172.102, and materials that meet the defining criteria for hazard classes and divisions in Part 173:

Hazardous substance means a material, including its mixtures and solutions, that:

- (1) Is listed in Appendix A to Sec. 172.101;
- (2) Is in a quantity, in one package, that equals or exceeds the reportable quantity (RQ) listed in Appendix A to Sec. 172.101; and
- (3) When in a mixture or solution.
  - (i) For radionuclides, conforms to paragraph 6 of Appendix A to Sec. 172.101.
  - (ii) For other than radionuclides, is in a concentration by weight that equals or exceeds the concentration corresponding to the RQ of the material, as shown in the following table:

RG Pounds (Kilograms)	Concentration By Weight	
	Percent	PPM
5,000 (2270)	10	1000,000
1,000 (454)	2	20,000
100 (45.4)	0.2	2,000
10 (4.54)	0.02	200
1 (0.454)	0.002	20

This definition does not apply to petroleum products that are lubricants or fuels (see 40 CFR 300.6).

**Hazardous waste** – For the purposes of this chapter, is any material subject to the Hazardous Waste Manifest Requirements of the U.S. EPA specified in 40 CFR Part 262.

**Limited quantity** – When specified as such in a section applicable to a particular material, is the maximum amount of a hazardous materials for which there may be specific labeling or packaging exception.

**Marking** – The descriptive name, identification number, instructions, cautions, weight, specification or UN marks, or combinations thereof, required by this subchapter on outer packaging of hazardous materials.

**Mixture** – A material composed of more than one chemical compound or element

**Name of contents** – The proper shipping name as specified in Sec. 172.101.

**Non-bulk packaging** – A packaging that has:

- (1) Maximum capacity of 450 L (119 gallons) as a receptacle for a liquid;
- (2) Maximum net mass less than 400 kg (882 pounds) and a maximum capacity of 450 L (119 gallons) or less as a receptacle for a solid; or
- (3) Water capacity greater than 454 kg (1,000 pounds) or less as a receptacle for a gas as defined in Sec 173.115.

**N.O.S.** – Not Otherwise Specified.

**Outage or ullage** – The amount by which a packaging falls short of being liquid full, usually expressed in percent by volume.

**Portable tank** – A bulk packaging (except a cylinder having a water capacity of 1,000 pounds or less) designed primarily to be loaded onto or on or temporarily attached to a transport vehicle or ship and equipped with skids, mountings, or accessories to facilitate handling of the tank by mechanical means. It does not include a cargo tank, tank car, multi-unit tank car tank, or trailer carrying 3AX, 3AAX, or 3T cylinders.

**Proper shipping name** – The name of the hazardous materials shown in Roman print (not italics) in Sec. 172.101.

**P.s.i. or psi** – Pounds per square inch.

**P.s.i.a. or psia** – Pounds per square inch absolute.

**Reportable quantity (RQ)** – The quantity specified in Column 3 of the Appendix to Sec. 172.101 for any material identified in Column 1 of the Appendix.

**PHMSA** – Pipeline and Hazardous Materials Safety Administration, U.S. Department of Transportation, Washington, D.C. 20590.

**Shipper's certification** – A statement on a shipping paper, signed by the shipper, saying he/she prepared the shipment properly according to law.

“This is to certify that the above named materials are properly classified, described, packaged, marked and labeled, and are in proper condition for transportation according to the applicable regulations or the Department of Transportation.”

or

“I hereby declare that the contents of this consignment are fully and accurately described above the proper

shipping name and are classified, packed, marked and labeled, and are in all respects in proper condition for transport according to applicable international and national government regulations.”

\* words may be inserted here to indicate mode of transportation (rail, aircraft, motor vehicle, vessel)

**Shipping paper** – A shipping order, bill of lading, manifest or other shipping document serving a similar purpose and containing the information required by Sec. 172.202, 172.203, and 172.204.

**Technical name** – A recognized chemical name or microbiological name currently used in scientific and technical handbooks, journals and texts.

**Transport vehicle** – A cargo-carrying vehicle, such as an automobile, van, tractor, truck, semi-trailer, tank car or rail car, used for the transportation of cargo by any mode. Each cargo-carrying body (trailer, rail car, etc.) is a separate transport vehicle.

**UN standard packaging** – A specification packaging conforming to the requirements in Subpart L and M of Part 178.

**UN** – United Nations

# Section 10: Pre-Trip Vehicle Inspection Test

During the pre-trip inspection, you must show that the vehicle is safe to drive. You may have to walk around the vehicle and point to or touch each item and explain to the examiner what you are checking and why. You will NOT have to crawl under the hood or under the vehicle.

## 10.1 All Vehicles

Study the following vehicle parts for the type of vehicle you will be using during the CDL skills exams. You should be able to identify each part and tell the examiner what you are looking for or inspecting.

### Engine Compartment (Engine Off) —

#### Leaks/hoses:

- Look for puddles on the ground.
- Look for dripping fluids on underside of engine and transmission.
- Inspect hoses for condition and leaks.

#### Oil level:

- Indicate where dipstick is located.
- See that oil level is within safe operating range. Level must be above refill mark.

#### Coolant level:

- Inspect reservoir sight glass, or
- (If engine is not hot), remove radiator cap and check for visible coolant level.

#### Power steering fluid:

- Indicate where power steering fluid dipstick is located.
- Check for adequate power steering fluid level. Level must be above refill mark.

**Engine compartment belts:** Check the following belts for snugness (up to 3/4-inch play at center of belt), cracks or frays:

- Power steering belt.
- Water pump belt.
- Alternator belt.
- Air compressor belt.

#### If any of the components above are not belt-driven, you must:

- Tell the examiner which component(s) are not belt-driven.
- Make sure component(s) are operating properly, are not damaged or leaking, and are mounted securely.

### Cab Check/Engine Start —

#### Clutch/gearshift:

- Depress clutch.
- Place gearshift lever in neutral (or park, for automatic transmissions).
- Start engine, then release clutch slowly.

#### Oil pressure gauge:

- Make sure oil pressure gauge is working.
- Check that pressure gauge shows increasing or normal oil pressure or that the warning light goes off.
- If equipped, oil temperature gauge should begin a gradual rise to the normal operating range.

#### Temperature gauge:

- Make sure the temperature gauge is working.
- Temperature should begin to climb to the normal operating range or temperature light should be off.

**Ammeter/voltmeter:** Check that gauges show alternator and/or generator is charging or that warning light is off.

**Mirrors and windshield:**

- Mirrors should be clean and adjusted properly from the inside.
- Windshield should be clean with no illegal stickers, no obstructions or damage to the glass.

**Emergency equipment:**

- Check for spare electrical fuses.
- Check for three red reflective triangles.
- Check for a properly charged and rated fire extinguisher.

**Note: If the vehicle is not equipped with electrical fuses, you must mention this to the examiner.**

**Steering play:**

- **Non-Power steering** – Check for excessive play by turning steering wheel back and forth. Play should not exceed 10 degrees (or about 2 inches on a 20-inch wheel).
- **Power steering** – With the engine running, check for excessive play by turning the steering wheel back and forth. Play should not exceed 10 degrees (or about 2 inches on a 20-inch wheel) before front left wheel barely moves.

**Wipers/washers:**

- Check that wiper arms and blades are secure, not damaged, and operate smoothly.
- If equipped, windshield washers must operate correctly.

**Lighting indicators:** Test that dash indicators work when corresponding lights are turned on:

- Right turn signal
- 4-way emergency flashers
- High-beam headlight

**Horn:**

- Check that air horn and/or electric horn work.

**Heater/defroster:**

- Test that the heater and defroster work.

**Parking brake check:** Apply parking brake only and make sure it will hold the vehicle by shifting into a lower gear and gently pulling against the brake.

**Hydraulic brake check:**

- Pump the brake pedal three times, then hold it down for five seconds. The brake pedal should not move (depress) during the 5 seconds.
- If equipped with a hydraulic brake reserve (back-up) system, with the key off, depress the brake pedal and listen for the sound of the reserve system electric motor.
- Check that the warning buzzer or light is off.

**Air brake check (air brake-equipped vehicles only): Failure to perform an air brake check will result in an automatic failure of the Vehicle Inspection Test.** Air brake safety devices vary. However, this procedure is designed to see that any safety device operates correctly as air pressure drops from normal to a low air condition. For safety purposes in areas where an incline is present, you will use wheel chocks during the air brake check.

Following is the proper procedure for inspecting the air brake system:

- With the engine running, build the air pressure to governed cut-out (100-125 psi). Shut off the engine, chock your wheels, if necessary, release the tractor protection valve and parking brake (push in), fully apply the foot brake and hold it for one minute. Check the air gauge to see if the air pressure drops more than 3 pounds in 1 minute (**single vehicle**) or 4 pounds in 1 minute (**combination vehicle**) with brake applied. When brake is unapplied, air pressure drops more than 2 pounds in 1 minute with a single vehicle and 3 pounds in 1 minute in a combination vehicle.
- Begin fanning off the air pressure by rapidly applying and releasing the foot brake. Low-air warning devices (buzzer, light, flag) should activate before air pressure drops below 60 psi.
- Continue to fan off the air pressure. At about 40 psi on a tractor-trailer combination vehicle, the tractor protection valve and parking brake valve should close (pop out). On other combination vehicle types and single vehicle types, the parking brake valve should close (pop out).

**Safety belt:** Check that the safety belt is securely mounted, adjusts and latches properly.

**Lights/reflectors:** Check that all external lights and reflective equipment are clean and functional. Light and reflector checks include:

- Clearance lights (red on rear, amber elsewhere)
- Headlights (high- and low-beams); taillights
- Turn signals
- 4-way flashers
- Brake lights
- Red reflectors (on rear) and amber reflectors (elsewhere)

**Note: Checks of brake turn signal and 4-way flasher functions must be done separately.**

## 10.2 External Inspection (School Bus, Truck/Tractor)

### Steering —

#### Steering box/hoses:

- Check that the steering box is securely mounted and not leaking. Look for any missing nuts, bolts and cotter keys.
- Check for power steering fluid leaks or damage to power steering hoses.

#### Steering linkage:

- See that connecting links, arms and rods from the steering box to the wheel are not worn or cracked.
- Check that joints and sockets are not worn or loose and that there are no missing nuts, bolts or cotter keys.

### Suspension —

#### Springs/air/torque:

- Look for missing, shifted, cracked or broken leaf springs.
- Look for broken or distorted coil springs.
- If vehicle is equipped with torsion bars, torque arms or other types of suspension components, check that they are not damaged and are mounted securely.
- Air ride suspension should be checked for damage and leaks.

#### Mounts:

- Look for cracked or broken spring hangers, missing or damaged bushings and broken, loose or missing bolts, U-bolts or other axle mounting parts. (The mounts should be checked at each point where they are secured to the vehicle frame and axle(s)).

**Shock absorbers:** Check that shock absorbers are secure and that there are no leaks.

**Note: Be prepared to perform the same suspension components inspection on every axle (power unit and trailer, if equipped).**

### Brakes —

#### Slack adjustors:

- Look for broken, loose or missing parts.
- The angle between the push rod and adjustor arm should be a little over 90 degrees when the brakes are released and not less than 90 degrees when the brakes are applied.
- When pulled by hand, the brake rod should not move more than 1 inch (with the brakes released).
- The manual adjustment of automatic slack adjustors is dangerous because it gives the vehicle operator a false sense of security about the effectiveness of the braking system.

**Brake chambers:** Check that brake chambers are not leaking, cracked or dented and are securely mounted.

**Brake hoses/lines:** Look for cracked, worn or leaking hoses, lines and couplings.

#### Drum brake:

- Check for cracks, dents or holes. Also check for loose or missing bolts.
- Brake linings (where visible) should not be worn dangerously thin.



**Brake linings:** On some brake drums, there are openings where the brake linings can be seen from outside the drum. For this type of drum, check that a visible amount of brake lining is showing.

**Note: Be prepared to perform the same brake components inspection on every axle (power unit and trailer, if equipped).**

#### **Wheels —**

**Rims:** Check for damaged or bent rims. Rims cannot have welding repairs.

**Tires:** The following items must be inspected on every tire:

- **Tread depth** – Check for minimum tread depth (4/32 on steering axle tires, 2/32 on all other tires).
- **Tire condition** – Check that tread is evenly worn and look for cuts or other damage to tread or sidewalls. Also, make sure that valve caps and stems are not missing, broken or damaged.
- **Tire inflation** – Check for proper inflation by using a tire gauge or by striking tires with a mallet or other similar device.

**Note: You will not get credit if you simply kick the tires to check for proper inflation.**

#### **Hub oil seals/axle seals:**

- Check that hub oil/grease seals and axle seals are not leaking and, if wheel has a sight glass, oil level is adequate.

#### **Lug nuts:**

- Check that all lug nuts are present, free of cracks and distortions, and show no signs of looseness such as rust trails or shiny threads.
- Make sure all bolt holes are not cracked or distorted.

#### **Spacers:**

- If equipped, check that spacers are not bent, damaged or rusted through.
- Spacers should be evenly centered, with the dual wheels and tires evenly separated.

**Note: Be prepared to perform the same wheel inspection on every axle (power unit and trailer, if equipped).**

#### **Side of Vehicle —**

##### **Doors/mirrors:**

- Check that doors are not damaged and that they open and close properly from the outside. Hinges should be secure with seals intact.
- Check that mirrors and mirror brackets are not damaged and are mounted securely with no loose fittings.

**Fuel tank(s):** Check that the tank(s) is secure, cap(s) is tight, and that there are no leaks from tank(s) or lines.

##### **Battery/box:**

- Wherever located, see that battery(s) is secure, connections are tight, and cell caps are present.
- Battery connections should not show signs of excessive corrosion.
- Battery box and cover or door must be secure.

##### **Drive shaft:**

- See that drive shaft is not bent or cracked.
- Couplings should be secure and free of foreign objects.

##### **Exhaust system:**

- Check system for damage and signs of leaks such as rust or carbon soot.
- System should be connected tightly and mounted securely.

**Frame:** Look for cracks, broken welds, holes or other damage to the longitudinal frame members, cross members, box and floor.

#### **Rear of Vehicle —**

**Splash guards:** If equipped, check that splash guards or mud flaps are not damaged and are mounted securely.

**Doors/ties/lifts:**

- Check that doors and hinges are not damaged and that they open, close and latch properly from the **outside** if equipped.
- Ties, straps, chains and binders must also be secure.
- If equipped with a cargo lift, look for leaking, damaged or missing parts and explain how it should be checked for correct operation.
- Lift must be fully retracted and latched securely.

**Tractor/Coupling —****Air/electric lines:**

- Listen for air leaks. Check that air hoses and electrical lines are not cut, chafed, spliced or worn (steel braid should not show through).
- Make sure air and electrical lines are not tangled, pinched or dragging against tractor parts.

**Catwalk:** Check that the catwalk is solid, clear of objects and securely bolted to tractor frame.

**Mounting bolts:**

- Look for loose or missing mounting brackets, clamps, bolts or nuts. Both the fifth wheel and the slide mounting must be solidly attached.
- On other types of coupling systems (i.e., ball hitch, pintle hook, etc.), inspect all coupling components and mounting brackets for missing or broken parts.

**Locking jaws:**

- Look into fifth wheel gap and check that locking jaws are fully closed around the kingpin.
- On other types of coupling systems (i.e., ball hitch, pintle, hook, etc.), inspect the locking mechanism for missing or broken parts and make sure it is locked securely. If present, safety cables or chains must be secure and free of kinks and excessive slack.

**Platform (fifth wheel):** Check for cracks or breaks in the platform structure that supports the fifth wheel skid plate.

**Release arm (fifth wheel):** If equipped, make sure the release arm is in the engaged position and the safety latch is in place.

**Kingpin/apron/gap:**

- Check that the kingpin is not bent.
- Make sure the visible part of the apron is not bent, cracked or broken.
- Check that the trailer is laying flat on the fifth wheel skid plate (no gap).

**Locking pins (fifth wheel):**

- If equipped, look for loose or missing pins in the slide mechanism of the sliding fifth wheel. If air powered, check for leaks.
- Make sure locking pins are fully engaged.
- Check that the fifth wheel is positioned properly so that the tractor frame will clear the landing gear during turns.

### 10.3 School Bus Only

**Emergency equipment:** In addition to checking for spare electrical fuses (if equipped), three red reflective triangles, and a properly charged and rated fire extinguisher, school bus drivers also must inspect the 7-item first-aid kit.

**Lighting indicators:** In addition to checking the lighting indicators listed in Section 10.2, school bus drivers also must check the following lighting indicators (internal panel lights):

- Alternately flashing amber lights indicator, if equipped.
- Alternately flashing red lights indicator.
- Strobe light indicator, if equipped.

**Lights/reflectors:** In addition to checking the lights and reflective devices listed in Section 10.2, school bus drivers also must check the following (external) lights and reflectors:

- Strobe light, if equipped.
- Stop arm light, if equipped.

- Alternately flashing amber lights, if equipped.
- Alternately flashing red lights.

**Stop arm:** If equipped, check the stop arm to see that it is mounted securely to the frame of the vehicle. Also, check for loose fittings and damage.

**Passenger entry/lift:**

- Check that the entry door is not damaged, operates smoothly, and closes securely from the **inside**.
- Hand rails are secure and the step light is working, if equipped.
- The entry steps must be clear with the treads not loose or worn excessively.
- If equipped with a handicap lift, look for leaking, damaged or missing parts and explain how lift should be checked for correct operation. Lift must be fully retracted and latched securely.

**Emergency exit:**

- Make sure all emergency exits are not damaged, operate smoothly and close securely from the **inside**.
- Check that any emergency exit warning devices are working.

**Seating:**

- Look for broken seat frames and check that seat frames are firmly attached to the floor.
- Check that seat cushions are attached securely to the seat frames.

## 10.4 Trailer

**Trailer Front —**

**Air/electrical connections:**

- Check that trailer air connectors are sealed and in good condition.
- Make sure glad hands are locked in place, free of damage or air leaks.
- Make sure the trailer electrical plug is firmly seated and locked in place.

**Header board:**

- If equipped, check the header board to see that it is secure, free of damage, and strong enough to contain cargo.
- If equipped, the canvas or tarp carrier must be mounted and securely fastened.
- On enclosed trailers, check the front area for signs of damage such as cracks, bulges or holes.

**Trailer Side —**

**Landing gear:**

- Check that the landing gear is fully raised, has no missing parts, crank handle is secure, and the support frame is not damaged.
- If power operated, check for air or hydraulic leaks.

**Doors/ties/lifts:**

- If equipped, check that doors are not damaged. Check that doors open, close and latch properly from the **outside**.
- Check that ties, straps, chains and binders are secure.
- If equipped with a cargo lift, look for leaking, damaged or missing parts and explain how it should be checked for correct operation.
- Lift should be fully retracted and latched securely.

**Frame:** Look for cracks, broken welds, holes or other damage to the frame, cross members, box and floor.

**Tandem release arm/locking pins:** If equipped, make sure the locking pins are locked in place and release arm is secured.

**Remainder of Trailer —** Refer to Section 10.2 for detailed inspection procedures regarding the following components:

- Wheels
- Suspension system
- Brakes
- Doors/ties/lift
- Splash Guards

## 10.5 Coach/Transit Bus

## **Passenger Items —**

### **Passenger entry/lift:**

- Check that entry doors operate smoothly and close securely from the **inside**.
- Check that hand rails are secure and, if equipped, that the step light(s) are working.
- Check that the entry steps are clear, with the treads not loose or worn excessively.
- If equipped with a handicap lift, look for any leaking, damaged or missing parts, and explain how it should be checked for correct operation.
- Lift should be fully retracted and latched securely.

### **Emergency exits:**

- Make sure all emergency exits are not damaged, operate smoothly, and close securely from the **inside**.
- Check that any emergency exit warning devices are working.

### **Passenger seating:**

- Look for broken seat frames and check that seat frames are firmly attached to the floor.
- Check that seat cushions are attached securely to the seat frames.

## **Entry/Exit —**

### **Doors/mirrors:**

- Check that entry/exit doors are not damaged and operate smoothly from the **outside**. Hinges should be secure with seals intact.
- Make sure the passenger exit mirrors and all external mirrors and mirror brackets are not damaged and are mounted securely with no loose fittings.

## **External Inspection of Coach/Transit Bus —**

**Level/air leaks:** Check that the vehicle is sitting level (front and rear), and if air-equipped, check for audible air leaks from the suspension system.

**Fuel tank(s):** Check that the fuel tank(s) is secure with no leaks from tank(s) or lines.

**Compartments:** Check that baggage and all other exterior compartment doors are not damaged, operate properly and latch securely.

### **Battery/box:**

- Wherever located, check that battery(s) is secure, connections are tight, and cell caps are present.
- Battery connections should not show signs of excessive corrosion.
- Check that battery box and cover or door is not damaged and is secure.

**Remainder of Coach/Transit Bus —** Refer to Section 10.2 for detailed inspection procedures regarding wheels.

**Remember, the Pre-Trip Vehicle Inspection must be passed before you can proceed to the Basic Vehicle Control Skills Exam.**

# Section 11: Basic Vehicle Control Skills Exam

Your basic control skills may be tested using one or more of the following exercises off-road or somewhere on the street during the driving exam:

- Stop at Line
- Straight line backing
- Alley dock
- Parallel park (driver side)
- Parallel park (conventional)
- Measured right turn
- Backward serpentine

These exercises are shown in Figures 11-1 through 11-7 on pages 124-127.

## 11.1 Scoring

**Crossing Boundaries** — The examiner will score the number of times you touch or cross over an exercise boundary line with any portion of your vehicle. Each encroachment will count as an error.

**Pull-ups** — In some of the exercises, the examiner also will score the number of times you stop and change direction or pull up during the exercise. Errors will be explained to you prior to the beginning of each exercise.

## 11.2 Exercises

**Stop at Line** — You may be asked to drive forward between two rows of cones and bring your vehicle to a complete stop as close as you can to the exercise boundary marked by an end line or set of cones (without going beyond the line or cones). (See Figure 11-1.)

**Straight Backing** — You may be asked to back your vehicle in a straight line between two rows of cones without touching or crossing over the exercise boundaries. (See Figure 11-2.)

**Alley Dock** — You may be asked to sight-side back your vehicle into an alley, bringing the rear of your vehicle as close as possible to the rear of the alley without going beyond the exercise boundary marked by a line or row of cones. (See Figure 11-3.)

**Parallel Park (Driver Side)** — You may be asked to park in a parallel parking space that is on your left. You must drive past the parking space and back into it bringing the rear of your vehicle as close as possible to the rear of the space without crossing side or rear boundaries marked by cones. You must try to get your vehicle (or trailer, if combination vehicle) completely into the space. (See Figure 11-4.)

**Parallel Park (Conventional)** — You may be asked to park in a parallel parking space that is on your right. You must drive past the parking space and back into it bringing the rear of your vehicle as close as possible to the rear of the space without crossing side or rear boundaries marked by cones. You must try to get your vehicle (or trailer, if combination vehicle) completely into the space. (See Figure 11-5.)

**Measured Right Turn** — You may be asked to drive forward and make a right turn around a cone. You should try to bring the right rear wheel(s) of your vehicle as close to the base of the cone as possible without hitting it. (See Figure 11-6.)

**Backward Serpentine** — You may be asked to back your vehicle through a 3-cone serpentine without touching any cones or crossing over the exercise (side) boundaries marked by cones. (See Figure 11-7.)

**Remember, you must pass the Pre-Trip Vehicle Inspection and the Basic Vehicle Control Skills Exam before proceeding to the On-Road Driving Exam.**

**Figure 11-1**  
**Stop at Line**

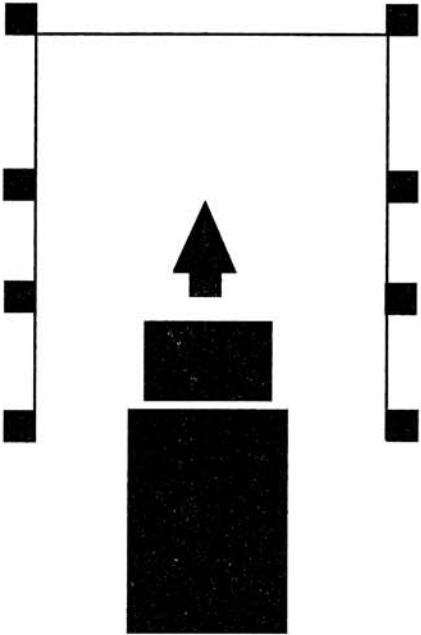

**Figure 11-2**  
**Straight Backing**

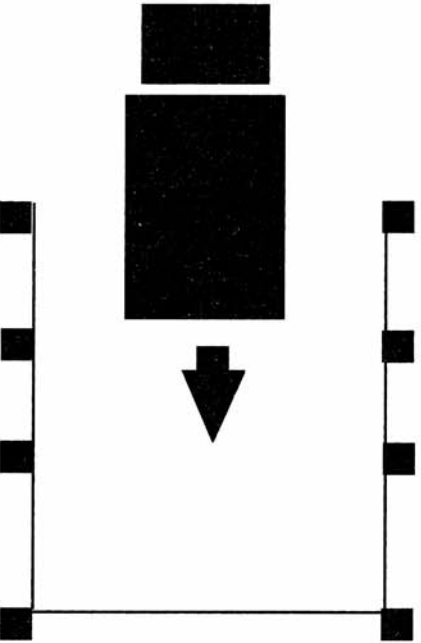

Figure 11-3  
Alley Dock

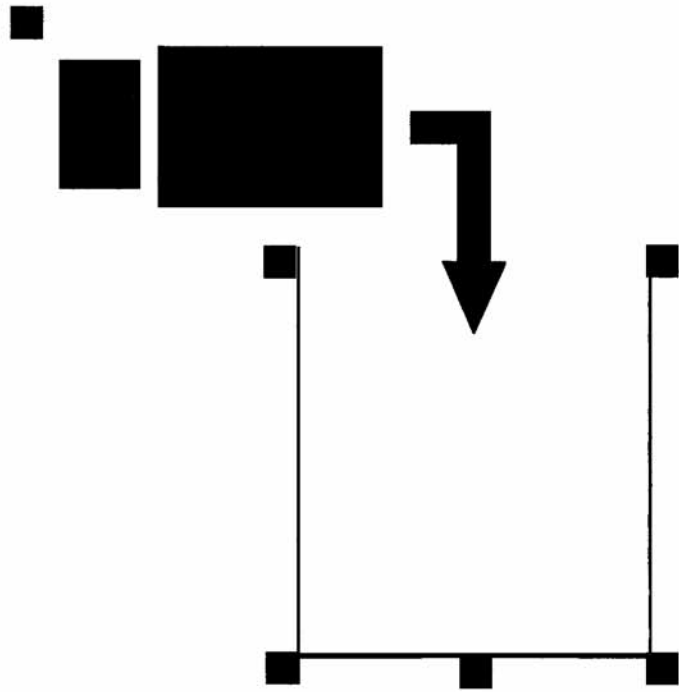

Figure 11-4  
Parallel Park  
(Driver Side)

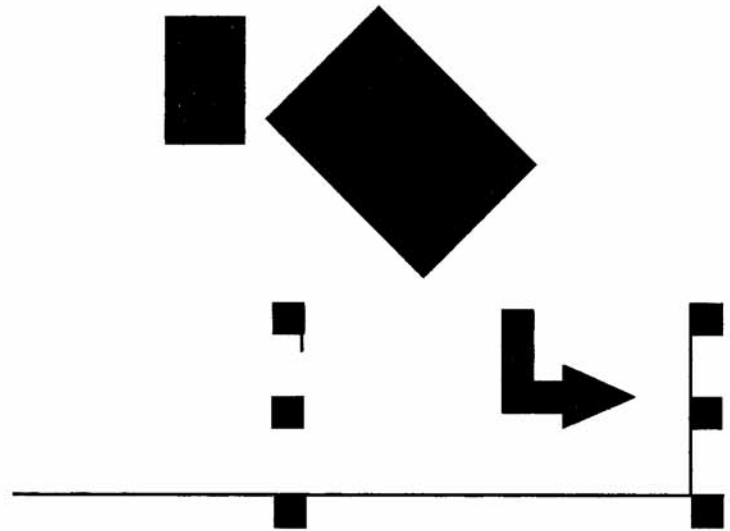

Figure 11-5  
Parallel Park

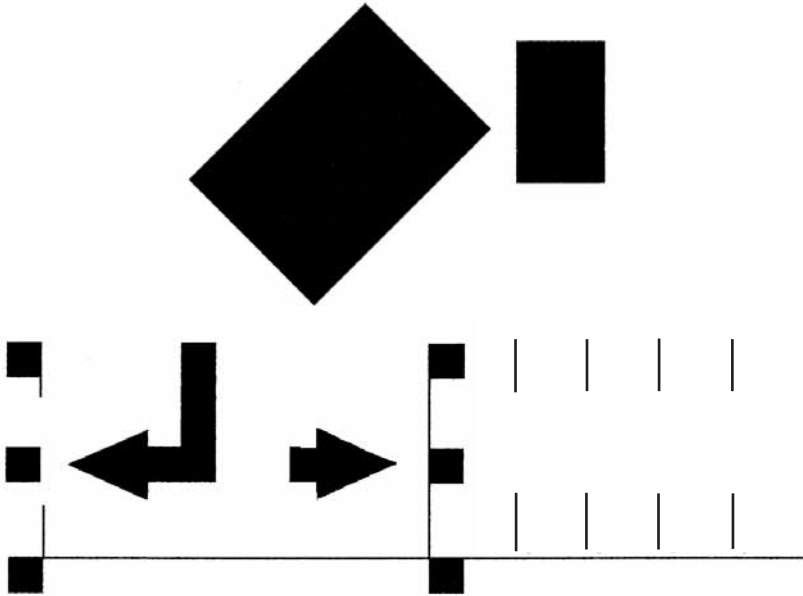

Figure 11-6  
Right Turn

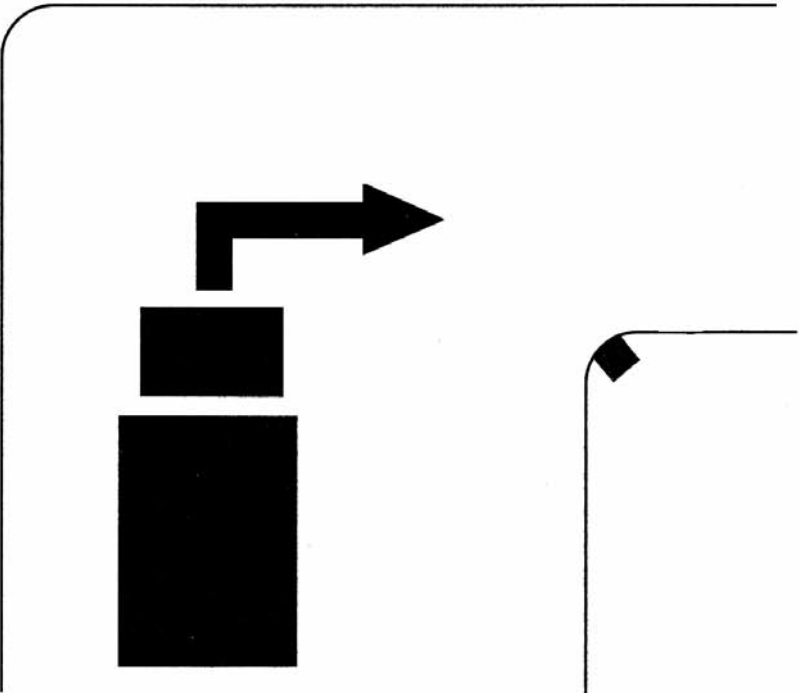
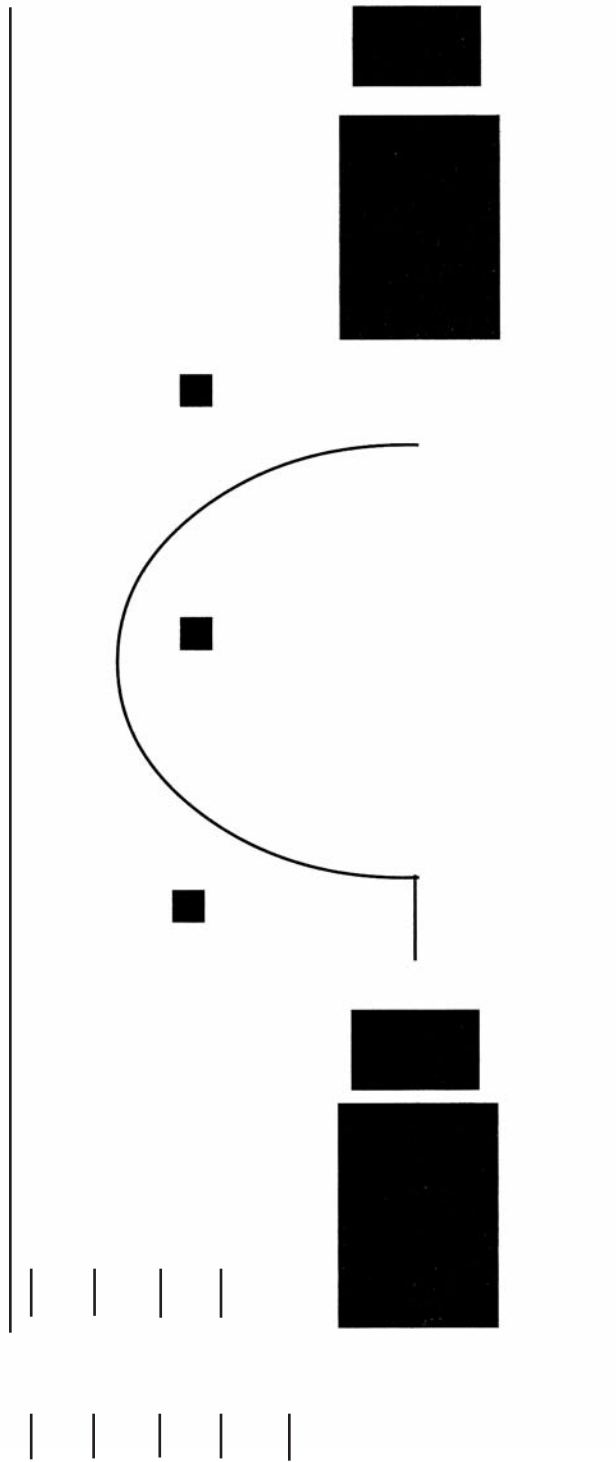



Figure 11-7  
Backward Serpentine



# Section 12: On-Road Driving Exam

You will drive over a test route that has a variety of traffic situations. At all times during the exam, you must drive in a safe and responsible manner.

During the driving exam, the examiner will be scoring you on specific driving maneuvers as well as on your general driving behavior. You will follow the directions of the examiner. Directions will be given to you so you will have plenty of time to do what the examiner has asked. You will not be asked to drive in an unsafe manner.

If your test route does not have certain traffic situations, you may be asked to simulate a traffic situation. You will do this by telling the examiner what you are or would be doing if you were in that traffic situation.

## 12.1 How You will be Tested

### Turns —

#### **You have been asked to make a turn:**

- Check traffic in all directions.
- Use turn signals and safely get into the lane needed for the turn.

#### **As you approach the turn:**

- Use turn signals to warn others of your turn.
- Slow down smoothly, change gears as needed to keep power, but do not coast unsafely. Unsafe coasting occurs when your vehicle is out of gear (clutch depressed or gearshift in neutral) for more than the length of your vehicle.

#### **If you must stop before making the turn:**

- Come to a smooth stop without skidding.
- Come to a complete stop behind the stop line, crosswalk or stop sign.
- If stopping behind another vehicle, stop where you can see the rear tires on the vehicle ahead of you (safe gap).
- Do not let your vehicle roll.
- Keep the front wheels aimed straight ahead.

#### **When ready to turn:**

- Check traffic in all directions.
- Keep both hands on the steering wheel during the turn.
- Do not change gears during the turn.
- Keep checking your mirror to make sure the vehicle does not hit anything on the inside of the turn.
- Vehicle should not move into oncoming traffic.
- Vehicle should finish turn in correct lane.

#### **After the turn:**

- Make sure turn signal is off.
- Get up to speed of traffic, use turn signal, and move into right-most lane when safe to do so (if not already there).

### Intersections —

#### **As you approach an intersection:**

- Check traffic thoroughly in all directions.
- Decelerate gently.
- Brake smoothly and, if necessary, change gears.
- If necessary, come to a complete stop (no coasting behind any stop signs, signals, sidewalks or stop lines, maintaining a safe gap behind any vehicle in front of you).
- Your vehicle must not roll forward or backward.

#### **When driving through an intersection:**

- Check traffic thoroughly in all directions.
- Decelerate and yield to any pedestrians and traffic in the intersection.
- Do not change lanes or shift gears while proceeding through the Intersection.
- Keep your hands on the wheel.

**Once through the intersection:**

- Continue checking traffic.
- Accelerate smoothly and change gears as necessary.

**Urban/Rural Straight** — During this part of the exam, you are expected to make regular traffic checks and maintain a safe following distance. Your vehicle should be centered in the proper lane (right-most lane), and you should keep up with the flow of traffic but not exceed the posted speed limit.

**Urban/Rural Lane Changes** — During the multiple lane portion of the urban and rural sections, you will be asked to change lanes to the left, and then back to the right. You should make the necessary traffic checks first, then use proper signals and smoothly change lanes when it is safe to do so.

**Expressways —****Before entering an expressway:**

- Check traffic.
- Use proper signals.
- Merge smoothly into the proper lane of traffic.

**Once on the expressway:**

- Maintain proper lane positioning, vehicle spacing and vehicle speed.
- Continue to check traffic thoroughly in all directions.

**You will be instructed to change lanes:**

- Make necessary traffic checks.
- Use proper signals.
- Change lanes smoothly when it is safe to do so.

**When exiting an expressway:**

- Make necessary traffic checks.
- Use proper signals.
- Decelerate smoothly in the exit lane.
- Once on the exit ramp, continue to decelerate within the lane markings and maintain adequate spacing between your vehicle and other vehicles.

**Stop/Start** — You will be asked to pull your vehicle over to the side of the road and stop as if you were going to get out and check something on your vehicle. You must check traffic thoroughly in all directions and move to the right-most lane or shoulder of road.

**As you prepare for the stop:**

- Check traffic.
- Activate your right turn signal.
- Decelerate smoothly, brake evenly, change gears as necessary.
- Bring your vehicle to a full stop without coasting.

**Once stopped:**

- Vehicle must be parallel to the curb or shoulder of the road and safely out of the traffic flow.
- Vehicle should not be blocking driveways, fire hydrants, intersections, signs, etc.
- Cancel the turn signal.
- Activate the four-way emergency flashers.
- Apply the parking brake.
- Move the gear shift to neutral or park.
- Remove your feet from the brake and clutch pedals.

**When instructed to resume:**

- Check traffic and mirrors thoroughly in all directions.
- Turn off the four-way flashers.
- Activate the left turn signal.
- When traffic permits, release the parking brake and pull straight ahead.

- Do not turn the wheel before your vehicle moves.
- Check traffic from all directions, especially to the left.
- Steer and accelerate smoothly into the proper lane when safe to do so.
- Once your vehicle is back into the flow of traffic, cancel the left turn signal.

**Curve — When approaching a curve:**

- Check traffic thoroughly in all directions.
- **Before** entering the curve, reduce speed so further braking or shifting is not required in the curve.
- Keep vehicle in the lane.
- Continue checking traffic in all directions.

**Upgrade — As you approach the upgrade:**

- Select the proper gear to maintain speed and not lug the engine.
- Check traffic thoroughly in all directions and move to the right-most or curb lane.
- If legal to do so, use the 4-way flashers if traveling too slowly for the flow of traffic.

**Downgrade —**

**Before starting down the grade:** Downshift as needed to help control engine speed and test brakes by gently applying the foot brake to ensure they are functioning properly. As your vehicle moves down the grade, continue checking traffic in all directions, stay in the right-most or curb lane and, if legal to do so, use the 4-way flashers if your vehicle is moving too slowly for traffic. Increase following distance and observe the following downhill braking procedures:

- Select a “safe” speed, one that is not too fast for the weight of the vehicle, length and steepness of the grade, weather and road conditions.
- Once a “safe” speed has been reached, apply the brake hard enough to feel a definite slowdown.
- When speed has been reduced to 5 mph below the “safe” speed, release the brakes. (This application should last for about 3 seconds.)
- Once speed has increased to the “safe” speed, repeat the procedure.

**Example:** If your “safe” speed is 40 mph, you should apply the brakes once your vehicle speed reaches 40 mph. Your brakes should be applied hard enough to reduce your speed to 35 mph. Once your vehicle speed reaches 35 mph, release the brakes. Repeat this procedure as often as necessary until you have reached the end of the downgrade. This braking technique is called “snubbing.”

When operating any commercial vehicle, do not ride the clutch, race the engine, change gears or coast while driving down the grade. At the bottom of the grade, be sure to cancel the 4-way flashers.

Not all test routes will contain an area of sufficient grade to test your skills adequately. **Therefore, you may be asked to simulate (verbally) driving up and down a steep hill.** You must be familiar with the upgrade/downgrade procedures so that you can explain and/or demonstrate them to the examiner at any time during the driving exam.

**Railroad Crossing —**

**Before reaching the crossing, all commercial drivers should:**

- Decelerate, brake smoothly, and shift gears as necessary.
- Look and listen for the presence of trains.
- Check traffic in all directions.

**Do not stop, change gears, pass another vehicle or change lanes while any part of your vehicle is in the crossing.**

If you are driving a bus, a school bus or a vehicle displaying placards, be prepared to observe the following procedures at every railroad crossing (unless the crossing is exempt):

- As the vehicle approaches a railroad crossing, activate the four-way flashers.
- Stop the vehicle within 50 feet but not less than 15 feet from the nearest rail.
- Listen and look in both directions along the track for an approaching train and for signals indicating the approach of a train. If operating a bus, you also may be required to open the window and door prior to crossing tracks.
- Keep hands on the steering wheel as the vehicle crosses the tracks.
- Do not stop, change gears or change lanes while any part of your vehicle is proceeding across the tracks.
- The 4-way flashers should be deactivated after the vehicle crosses the tracks.

**Not all driving exam routes will have a railroad crossing. You may be asked to explain and demonstrate the proper railroad crossing procedures to the examiner at a simulated location.**

**Bridge/Overpass/Sign** — After driving under an overpass, you may be asked to tell the examiner what the posted clearance or height was. After going over a bridge, you may be asked to tell the examiner what the posted weight limit was. If your test route does not have a bridge or overpass, you may be asked about another traffic sign. When asked, be prepared to identify and explain to the examiner any traffic sign that may appear on the route.

**Driving Exam Requirements —**

**During the driving exam you must:**

- Wear your safety belt.
- Obey all traffic signs, signals, and laws.
- Complete the test without an accident or moving violation.

**Scoring** — You will be scored on your overall performance in the following general driving behavior categories:

**Clutch usage** (for manual transmission):

- Always use the clutch to shift.
- Double-clutch if vehicle is equipped with non-synchronized transmission.
- Do not rev or lug the engine.
- Do not ride the clutch to control speed, coast with the clutch depressed, or “pop the clutch.”

**Gear usage** (for manual transmission):

- Do not grind or clash gears.
- Select a gear that does not rev or lug engine.
- Do not shift in turns and intersections.

**Brake usage:**

- Do not ride or pump brake.
- Do not brake harshly. Brake smoothly using steady pressure.

**Lane usage:**

- Do not put vehicle over curbs, sidewalks or lane markings.
- Stop behind stop lines, crosswalks or stop signs.
- Complete a turn in the proper lane on a multiple-lane road (vehicle should finish a left turn in the lane directly to the right of the center line).
- Finish a right turn in the right-most (curb) lane.
- Move to or remain in right-most lane unless lane is blocked.

# Hazardous Materials Warning Labels

Actual label size: 100 mm (3.9 inches) on all sides

**CLASS 1 Explosives:**  
Divisions 1.1, 1.2, 1.3, 1.4, 1.5, 1.6



**CLASS 2 Gases:**  
Divisions 2.1, 2.2, 2.3



**CLASS 3 Flammable Liquid**



**CLASS 4 Flammable Solid, Spontaneously Combustible, and Dangerous When Wet:**  
Divisions 4.1, 4.2, 4.3



**CLASS 5 Oxidizer, Organic Peroxide:**  
Divisions 5.1 and 5.2



\$172.411  
\* Include compatibility group letter.  
\*\* Include division number and compatibility group letter.

**CLASS 6 Poison (Toxic), Poison Inhalation Hazard, Infectious Substance:**  
Divisions 6.1 and 6.2



**CLASS 7 Radioactive**



**CLASS 8 Corrosive**



**CLASS 9 Miscellaneous Hazardous Material**



**For Aircraft Only**



Infectious Substance label not required on an outer packaging, if the OSHA Biohazard Marking (29 CFR 1910.103(g)) is used. The CDC Ethologic Agent Label must be used as prescribed in 42 CFR 72.3 and 72.6.

\$172.405(c), \$172.429, \$172.430, \$172.432  
\$172.436, \$172.438, \$172.440, \$172.450  
\$172.442  
\$172.446  
\$172.411  
\$172.448

## HAZARDOUS MATERIALS MARKINGS

Fumigant Marking

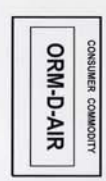

**INNER PACKAGES COMPLY WITH PRESCRIBED SPECIFICATIONS**



\$172.312(a)

\$172.322

\$172.325

\$172.332(a)

\$172.302(a) and \$173.9

\$172.313(a)

\$172.316(a)

\$172.316(a)(1)

Keep a copy of the Emergency Response Guidebook handy!